

Historic, Archive Document

Do not assume content reflects current scientific knowledge, policies, or practices.

a SD11
A42
Reserve

cat/sta



United States
Department of
Agriculture

Forest Service

Rocky Mountain
Forest and Range
Experiment Station

Fort Collins,
Colorado 80526

General Technical
Report RM-142



Biology and Conservation of Northern Forest Owls

Symposium Proceedings

February 3 - 7, 1987
Winnipeg, Manitoba

MANITOWA
FEB 10 1987
LIBRARY
WISCONSIN
STATE UNIVERSITY
MADISON

Nero, Robert W.; Clark, Richard J.; Knapton, Richard J.; Hamre, R. H., eds. 1987. Biology and conservation of northern forest owls: symposium proceedings. 1987 Feb. 3-7; Winnipeg, Manitoba. Gen. Tech. Rep. RM-142. Fort Collins, CO: U.S. Department of Agriculture, Forest Service, Rocky Mountain Forest and Range Experiment Station; 309 p.

Proceedings of this first international symposium consist of 47 presented papers covering 15 owl species, and 4 workshops dealing with capture, telemetry, census, and management techniques. Basic information on habitat preferences, home range size, detecting lesser known owls, etc. will be invaluable to managers of wildlife and of forested lands; techniques information will be invaluable to researchers.

SUPPORTERS:

Air Canada
Canadian Nature Federation
City of Winnipeg
Manitoba Naturalists Society
Manitoba Wildlife Federation
Richardson Century Fund
Saskatchewan Natural History Society

EXHIBITORS:

Hazel Birt, James Carson, Audrey Casey,
Carole Dempster, Roy Erskine, Tim Garton,
Paul Guyot, Dennis Hillman, William McCracken,
Terry McLean, Glen Moncrieff, Heather North,
Lynn Ohryn, Norm Peterson, Bob Pollock,
Jim Russell, Peter Sawatsky, Roy Simmons,
Robert R. Taylor, and Clarence Tillenius.

COVER:

A Great Gray Owl drops in for
dinner near Helsinki, Finland.
Photo by Seppo Niiranen.

Biology and Conservation of Northern Forest Owls

Symposium Proceedings

**February 3 - 7, 1987
Winnipeg, Manitoba**

Editors:

**Robert W. Nero, Manitoba Department of Natural Resources
Richard J. Clark, York College of Pennsylvania
Richard J. Knapton, University of Manitoba
R. H. Hamre, Rocky Mountain Forest & Range Experiment Station**

Sponsors:

**Manitoba Department of Natural Resources
USDA Forest Service
Natural Resources Institute, University of Manitoba
World Wildlife Fund Canada
World Wildlife Fund US
The Wildlife Society**

Preface

IN 1983, Bob Nero began to talk about the need for a gathering of "owlologists" to compare notes on Great Gray Owl research and conservation. At that time, he contacted a few colleagues who also expressed a great need to review their work and exchange ideas on research techniques. Little did any of us realize at the time that the need was international, that the forum would be 3 1/2 days of technical presentations and workshops, and that "owlologists" would be discussing all northern forest owl species at the first-of-its-kind Symposium held in Winnipeg, Manitoba, Canada, February 3-7, 1987.

The timing was right on. The organizers worked hard. Sponsors' interest was high. Eventually a program was developed that included a field trip, exhibits, musical and social events, all planned to provide a restful change from intense discussions and to effect international camaraderie. It worked. How well it worked can only be known from those who were there!

As the coordinating chairman for the Symposium, I had the pleasure of working with a central committee composed of Bill Koonz (Arrangements), Bob Nero (Program) and Ken De Smet (Finances). Excellent support for this committee came from office staff, university professors, volunteers, students and biologists. They are: Lori Bartley, Lynn Bergeron, Don Campbell, Brendan Carruthers, Maureen Collins, Herb Copland, Dr. Jon Gerrard, Chris Hofer, Kathryn Johnston, Rudolf Koes, Dr. Erkki Korpimäki, Dr. Emil Kucera, John Morgan, Ted Muir, Dr. Ronald Ryder, Ulrike Schneider, Renate Scriven, Dr. Spencer Sealy, Don Sexton, Dan Soprovich, Linda Tardiff, Rick Wishart and Rosemarie Young.

The production of a printed Proceedings was accomplished in record fashion due to the outstanding cooperation of the many contributors who submitted camera-ready manuscripts and illustrations. Bob Hamre is obviously a seasoned

veteran in producing a quality publication. He was aptly assisted by the editorial committee consisting of Bob Nero, Dick Clark and Richard Knapton. Only the authors are responsible for the material contained in their papers; their views are not necessarily those of the sponsors, i.e., the USDA Forest Service, the Wildlife Society, World Wildlife Fund, University of Manitoba, and the Manitoba Department of Natural Resources.

How have northern forest owls benefitted from this Symposium? There was an initial, very positive response from the public and local news media to the holding of such an event. However, the full effect of this meeting will not be realized until the technical knowledge exchanged during the Symposium and recorded in this document is incorporated into action programs by management agencies and pushed by conservation groups. This challenge was presented by Monte Hummel in his opening address and recognized by Dick Clark in his summary remarks.

Canada celebrates 100 years in wildlife conservation in 1987 under the theme Wildlife '87: Gaining Momentum. During a time when nongame wildlife programs are fledging and taking wing in Canada, it is appropriate that we would begin the second 100 years with a Northern Forest Owl Symposium as the first event of this celebration. By the time the next Northern Forest Owl Symposium is held, I hope that action programs will have been implemented to protect owls where needed and to ensure that the public will have a greater understanding and appreciation of the role of owls in the natural environment.

Merlin W. Shoesmith,
Chief, Biological Services,
Wildlife Branch,
Department of Natural Resources,
Winnipeg, Manitoba.

Contents

	Page
Preface: <i>Merlin W. Shoesmith</i>	i
Northern Forest Owls: Special Presentations	
Official Opening Remarks	1
<i>Leonard E. Harapiak</i>	
Owls: Who Gives a Hoot?	2
<i>Monte Hummel</i>	
Symposium Summary and Concluding Remarks	4
<i>Richard J. Clark</i>	
Evolution, Structure, and Ecology of Northern Forest Owls (Keynote Address)	9
<i>R. Ake Norberg</i>	
A Second Chance for Owls (Banquet Address)	44
<i>Katherine McKeever</i>	
Special Aspects of Northern Forest Owls	
<i>Ronald A. Ryder and W. Bruce McGillivray, Chairpersons</i>	
Distributional Status and Literature of Northern Forest Owls	47
<i>Richard J. Clark, Dwight G. Smith, and Leon Kelso</i>	
Nearly Synchronous Cycles of the Great Horned Owl and Snowshoe Hare in Saskatchewan	56
<i>C. Stuart Houston</i>	
Reversed Size Dimorphism in 10 Species of Northern Owls	59
<i>W. Bruce McGillivray</i>	
Disease Susceptibility in Owls	67
<i>D. Bruce Hunter, Kay McKeever, Larry McKeever, and Graham Crawshaw</i>	
The Role of the Whitefish Point Bird Observatory in Studying Spring Movements of Northern Forest Owls	71
<i>Thomas W. Carpenter</i>	
Strix Owls of Northern Forests	
<i>Heimo Mikkola, Richard R. Howie, and Robert W. Nero, Chairpersons</i>	
Reintroduction of the Ural Owl in the Bavarian National Park, Germany	75
<i>Wolfgang T. Scherzinger</i>	
Mate and Nest-Site Fidelity in Ural and Tawny Owls	81
<i>Pertti Saurola</i>	
Nest Platforms for Great Gray Owls	87
<i>Evelyn L. Bull, Mark G. Henjum, and Ralph G. Anderson</i>	
Biology of the Great Gray Owl in Interior Alaska	91
<i>Timothy O. Osborne</i>	
A Floristic Analysis of Great Gray Owl Habitat in Aitkin County, Minnesota	96
<i>Mark F. Spreyer</i>	
Movement Strategies, Mortality, and Behavior of Radio-Marked Great Gray Owls in Southeastern Manitoba and Northern Minnesota	101
<i>James R. Duncan</i>	
Summer Habitat Use by Great Gray Owls in Southeastern Manitoba	108
<i>Maria C. Servos</i>	
Status of the Great Gray Owl in Finland	115
<i>Olavi Hilden and Tapio Solonen</i>	

Territorial Aspects of Barred Owl Home Range and Behavior in Minnesota	121
<i>Thomas H. Nicholls and Mark R. Fuller</i>	
Barred Owls and Nest Boxes — Results of a Five-Year Study in Minnesota	129
<i>David H. Johnson</i>	
Distribution, Density, and Habitat Relationships of the Barred Owl in Northern New Jersey	135
<i>Thomas Bosakowski, Robert Speiser, and John Benzinger</i>	
Ecology of the Three Species of <i>Strix</i> Owls in Finland	144
<i>Heimo Mikkola</i>	
Surnia Owls of Northern Forests	
<i>Wolfgang Scherzinger, Chairperson</i>	
Home Range Size of Hawk Owls: Dependence on Calculation Method, Number of Tracking Days, and Number of Plotted Perchings	145
<i>Bjorn T. Baekken, Jan O. Nybo, and Geir A. Sonerud</i>	
Observations of the Northern Hawk Owl in Alberta	149
<i>Edgar T. Jones</i>	
Foraging Activity and Growth of Nestlings in the Hawk Owl: Adaptive Strategies Under Northern Conditions	152
<i>Kauko Huhtala, Erkki Korpimaki, and Erkki Pulliainen</i>	
Aegolius Owls of Northern Forests	
<i>R. Ake Norberg and Ann Swengel, Chairpersons</i>	
Sexual Size Dimorphism and Life-History Traits of Tengmalm's Owl: A Review	157
<i>Erkki Korpimaki</i>	
Annual, Seasonal, and Nightly Variation in Calling Activity of Boreal and Northern Saw-Whet Owls . . .	162
<i>David A. Palmer</i>	
Distribution and Status of the Boreal Owl in Colorado	169
<i>Ronald A. Ryder, David A. Palmer, and John J. Rawinski</i>	
Movements and Home Range Use by Boreal Owls in Central Idaho	175
<i>Gregory D. Hayward, Patricia H. Hayward, and Edward O. Garton</i>	
Occurrence of the Boreal Owl in Northeastern Washington	185
<i>M. W. O'Connell</i>	
Home Range of Tengmalm's Owl: A Comparison Between Nocturnal Hunting and Diurnal Roosting . . .	189
<i>Bjorn V. Jacobsen and Geir A. Sonerud</i>	
The Breeding Biology of Northern Saw-Whet Owls in Southern British Columbia	193
<i>Richard J. Cannings</i>	
Study of a Northern Saw-Whet Owl Population in Sauk County, Wisconsin	199
<i>Scott R. Swengel and Ann B. Swengel</i>	
Remigial Molt in Fall Migrant Long-Eared and Northern Saw-Whet Owls	209
<i>David L. Evans and Robert N. Rosenfield</i>	
Bubo, Asio, and Otus Owls of Northern Forests	
<i>Geir A. Sonerud and C. Stuart Houston, Chairpersons</i>	
Dispersal and Mortality of Juvenile Eagle Owls Released from Captivity in Southeast Norway as Revealed by Radio Telemetry	215
<i>Runar S. Larsen, Geir A. Sonerud, and Ole H. Stensrud</i>	
Geographic Variations in the Diet of Eagle Owls in Western Mediterranean Europe	220
<i>Jose A. Donazar</i>	
Addled Eggs in Great Horned Owl Nests in Saskatchewan	225
<i>C. Stuart Houston, Roy D. Crawford, and Donald S. Houston</i>	

Some Features of Long-Eared Owl Ecology and Behavior: Mechanisms Maintaining Territoriality	229
<i>Vladimir I. Voronetsky</i>	
Food and Food Ecology of the Long-Eared Owl in an Agricultural Area	231
<i>Josef Kren</i>	
Fidelity to Territory and Mate in Flammulated Owls	234
<i>Richard T. Reynolds and Brian D. Linkhart</i>	
The Nesting Biology of Flammulated Owls in Colorado	239
<i>Richard T. Reynolds and Brian D. Linkhart</i>	
Distribution, Habitat Selection, and Densities of Flammulated Owls in British Columbia	249
<i>R. Richard Howie and Ralph Ritcey</i>	
Censusing Screech Owls in Southern Connecticut	255
<i>Dwight G. Smith, Arnold Devine, and Dan Walsh</i>	
Status of the Eastern Screech Owl in Saskatchewan with Reference to Adjacent Areas	268
<i>Christopher I. G. Adam</i>	
Effects of Environmental Variables on Responses of Eastern Screech Owls to Playback	277
<i>Thomas W. Carpenter</i>	
Current Status and Habitat Associations of Forest Owls in Western Montana	281
<i>Denver W. Holt and J. Michael Hillis</i>	
People Power: Help for the Owl Bander	289
<i>C. Stuart Houston</i>	
Northern Forest Owl Workshops	
Capture Techniques for Owls	291
<i>Evelyn L. Bull</i>	
Owl Telemetry Techniques	294
<i>Thomas H. Nicholls and Mark R. Fuller</i>	
Owl Management Techniques	302
<i>Katherine V. Haws</i>	
Owl Census Techniques <i>Dwight G. Smith</i>	304
General Census Considerations	304
<i>Dwight G. Smith and Tom Carpenter</i>	
Census of Barred Owls and Spotted Owls	307
<i>Tom Bosakowski</i>	
Census of Flammulated Owls	308
<i>Richard T. Reynolds</i>	



Photo by Robert R. Taylor

Official Opening Remarks¹

Leonard E. Harapiak²

Mr. Chairman, distinguished guests, owl biologists, ladies and gentlemen. On behalf of Premier Pawley and the Province of Manitoba, I will officially open the Northern Forest Owl Symposium. To those visiting delegates from northern Europe, the United States, and other Canadian provinces and territories: welcome to Manitoba! Your presence here has ensured that this meeting will be a success. I am advised that some of you have gone to considerable effort to get here. I hope that your brief stay in Winnipeg and participation in this conference will be very enjoyable and will bring you back soon.

I would also like to congratulate the organizers of this event. I am sure that their hard work in developing the program and making all the arrangements will be evident during the next four days. I understand that the auction being held later this evening features contributions by Manitoba wildlife artists, many of them exhibiting their work during the symposium. Thank you to all contributors; the proceeds will go to support the symposium and to owl conservation.

1986 was and 1987 will be special years for wildlife conservation in Canada. Last year, the World Wildlife Fund, a network of 23 national organizations working to maintain the biological resources of the earth, celebrated its 25th anniversary. The Canadian affiliate has been a particularly good friend to wildlife in Manitoba, and I intend to speak more directly on that later this evening.

The Canadian Wildlife Federation also celebrated its 25th year in providing support for the protection of natural resources in Canada. Coincidentally, 1986 was the 25th anniversary of Manitoba's Wildlife Management Area Program. Over 7 million acres in 59 areas have been designated for the management of wildlife and public use of the resource. Many of them greatly assist in conserving owls.

During 1987, Canada will celebrate 100 years of wildlife conservation. As an initiative by the Canadian Nature Federation, a number of major events

will occur under the theme "Wildlife '87: Gaining Momentum". They include:

- the Northern Forest Owl Symposium
- International CITES conference in Ottawa July 12-24th
- Last Mountain Lake dedication ceremonies with Prince Philip in Saskatchewan

I am very pleased that Manitoba will be the first to celebrate 100 years of conservation in Canada by focusing attention on owls of the boreal forest. This is the first symposium of its kind to be held anywhere in the world. It is my hope that it will not be the last. It should become a regular event to bring together the best collective biological wisdom on forest owls and to provide decision makers with the basis to make sound decisions to conserve populations of these magnificent birds.

One of these magnificent birds is with us tonight. Lady Gray¹, a Great Gray Owl, has been maintained in captivity by Dr. Robert Nero of my staff for use in public education and research for the last 2½ years. She has visited many school rooms and shopping malls and has captured the hearts of many Manitobans.

While southeastern Manitoba has a substantial population of these owls, it is still declared a rare species across Canada. Manitobans have a special obligation to ensure that Great Gray Owls persist in Canada and to afford protection to other owl species in jeopardy.

Because of the symbolic nature of Lady Gray¹, I expect that the Great Gray Owl will be officially designated as Manitoba's provincial bird during the forthcoming session of the Manitoba Legislature.

In order to ensure that Great Gray Owls as well as all wildlife species will receive the necessary resources required to manage and protect them, I have asked my staff to prepare a non-game plan. This plan will ensure efficient use of available funds, staff, student and volunteer time. I will as well need the help of many of you and others as leaders of conservation organizations here tonight to co-operatively support its implementation.

In closing, I would like to express my gratitude to the co-sponsors and contributors who have come forward with their generous support that will make this symposium a success. It is with great personal pleasure that I now declare the Northern Forest Owl Symposium to be officially open.

¹Presented at the symposium, Biology and Conservation of Northern Forest Owls, Feb. 3-7, 1987, Winnipeg, Manitoba. USDA Forest Service General Technical Report RM-142.

²Minister, Manitoba Department of Natural Resources.

Owls: Who Gives a Hoot?¹

Monte Hummel²

Owls mean something to me. They've kept me company, lulled me to sleep and just generally made life more worth living. I'm sure the same is true for everyone else in this room. Yet, what thanks have people extended to owls for their companionship and for their very important role in nature?

Well, on a world-wide basis IUCN already lists 13 species of owls in the Red Data Book. I'm always interested to hear my colleague Jen's Wahlstedt from Sweden telling me exactly how many pairs of Eagle Owls they have and where each one is.

Here in Canada, of course, we've managed to put one owl species on each of our endangered, threatened and rare lists - the Spotted Owl, Burrowing Owl and Great Gray Owl respectively. We've cut the old growth timber habitat of the Spotted Owl in B.C. We've plowed up, shot and likely poisoned the Burrowing Owl in Alberta, Saskatchewan and Manitoba. And, although it has always been found in relatively low numbers, we're making sure the Great Gray Owl stays that way by cutting down some of its critical Tamarack nesting areas right here in Manitoba.

If you combine the IUCN world assessment to date, add the Canada lists with other similar national inventories, throw in a little common sense, and I think an intelligent guess would be that up to 20% of the world's 133 owl species have been either endangered or seriously jeopardized by the activities of people.

Makes you think doesn't it?

It makes me think. I makes me wonder whether the creator didn't put these birds on the planet to hoot out a question (if you'll pardon the pun), "Just who who the hell do you humans think you are?"

Well, who indeed do we think we are? Who are we, one species, to have assumed control of the earth's evolutionary fate, responsible for the extinction of other species at an unprecedented level? Who are we to cause extinctions, conservatively speaking, at the rate of three per day, by the late eighties one per hour, and by the turn of the century up to one million species either endangered or extinct? Who are we to have unleashed a rate of extinction 400 times greater than anything experienced in recent geological time? And who are we to have been responsible for all this, but to have refused responsibility for it?

Perhaps the numbers and estimates I gave earlier regarding owls don't really indicate that owls as a species-group are in any greater risk than any other. Rather, and this may be the most important conclusion, owls are quite representative of a trend being experienced by all forms of wildlife.

The organization I represent, World Wildlife Fund, is best known for trying to do something about rescuing species from extinction, or "preserving genetic diversity" as it is stated more grandly in the World Conservation Strategy. Since our founding in 1961, WWF has raised over \$200 million for 5,000 projects in 130 countries.

Peanuts, that amount of money wouldn't even buy you five F-18 Jet Fighters, and Canada just ordered 138.

Some enterprising journalist recently identified 100 species saved as a direct result of WWF's efforts.

Peanuts again, when you consider we'll be losing 100 per day within a matter of years.

So what can we do that amounts to anything? Simply stated, but it's difficult to do, if we seriously want to stem the tide of human-caused extinctions, we must focus our efforts on conserving biological systems. Save a system and you save the components. The cold fact is that we are losing entire systems - for example the tropical forest and wetlands on an international scale, for example the prairie grasslands the Carolinian Zone, and wetlands here in Canada.

Of course this is precisely why WWF Canada last year opened an office in Calgary and launched our three-year Wild West program which has

¹Opening address presented at the symposium, Biology and Conservation of Northern Forest Owls, Feb. 3-7, 1987, Winnipeg, Manitoba. USDA Forest Service General Technical Report RM 142.

²President, World Wildlife Fund Canada.

already funded over 30 projects involving 40 different conservation groups and agencies from western Canada. We are also drafting a Prairie Conservation Action Plan which will serve as a blueprint for action on the remaining tallgrass, mixed grass, shortgrass and aspen parkland prairie eco-systems - all of them more than 80% lost to cultivation or grazing. This work is being done in co-operation with ranchers, farmers and other land owners to encourage private stewardship and conservation farming techniques. Since native grasslands are the most endangered wildlife habitats in Canada, WWF has taken the further step of inviting our International President, Prince Philip, to visit western Canada in this 100th year of wildlife conservation, to publicize the international significance of western Canada's conservation concerns. All of this is pursuing that principle I mentioned earlier: "Save a system and you save the components." In this case, save the prairies and you save about half the birds and mammals classified as endangered so far in Canada.

To be sure, there are species-related steps that can be taken. Getting back to our owls, for example, WWF has supported conservation work on all three species listed by the Committee on the Status of Endangered Wildlife in Canada.

For the endangered Spotted Owl, we are supporting a captive breeding program at the Owl Rehabilitation Research Foundation with an eye to reintroductions in this country.

For the threatened Burrowing Owl, we have supported the first banding programs in all three prairie provinces. We are working co-operatively with landowners to protect pastures where nesting

burrows are found. We are helping pioneer artificial underground nesting boxes, and we are assisting with the drafting of a national recovery plan.

For the Great Gray Owl, we have supported work in Ontario into the question of why these birds invade the southern part of that province during winter, and we have supported Bob Nero's work on radio telemetry and protection of the nesting habitat in southeastern Manitoba.

However, there is one more thing you could do, and I want to close by proposing it this evening.

WWF Canada is already assisting with the publication costs of the proceedings of this symposium, and I am sure these will serve as a useful update on the behavior, ecology and physiology of North America's owls for researchers everywhere. But really, all the outside world wants to know is what overall trend do these more technical papers indicate? Therefore could we not take an additional step with a statement of concern, perhaps similar to the wolf manifesto produced by IUCN's specialist group on that species? Specifically, I'm proposing that a message be sent out at the closing of this meeting that says, hey, our beast is appearing on these bloody endangered species lists! We are concerned and we are speaking up. Because what is happening to owls is sadly representative of what's happening to wildlife in general. And we find this situation just plain unacceptable. It cannot and must not continue.

Who gives a hoot about owls? We do! Now it's time to let a few more people know about it.

Symposium Summary and Concluding Remarks¹

Richard J. Clark²

Abstract.--To summarize the geographic location of the researchers: of the 150 registrants, 22 (15%) were from eight European countries (Norway, Finland, and Sweden topped the list), 83 (53%) were from five Canadian provinces and one Territory, and 45 (30%) were from 17 States of the United States. Of the 52 papers presented, 39 dealt with research on a single species, four dealt with two species, and seven dealt with more than two species. Of those, three dealt with community studies of owls. Eighteen papers dealt with aspects of the basic behavior of species and 12 papers dealt with the habitat of owl species in some detail. The conference brought from obscurity some of the basic biology of Otus flammeolus, the Flammulated Screech Owl, and its distribution on the periphery of its range in British Columbia, and the latter can also be said about the population of Spotted Owls, Strix occidentalis, in that same province. Much basic information that will be invaluable to land and wildlife managers -- such as habitat preference, home range size, detecting lesser known owls, etc. -- was presented.

SUMMARY AND CONCLUDING REMARKS

Someone has said that to summarize a conference such as this has been, is an impossible task but I would like to thank Dr. Robert Nero for providing the opportunity to try. I would also like to thank, on behalf of the participants if I might be so presumptuous, Dr. Merlin Shoemith and all of the other Manitobans for the splendid job they have done in organizing and executing this Symposium. Having lived in Manitoba for a couple of summers I found the people of this province to be memorably hospitable and this trip has reinforced that feeling of warmth in spite of the outside temperatures.

¹Concluding address at the symposium, Biology and Conservation of Northern Forest Owls, Feb. 3-7, 1987, Winnipeg, Manitoba. USDA Forest Service General Technical Report RM-142.

²Richard J. Clark is Professor of Biology at York College of Pennsylvania, York, Pa. 17403-3426.

I shall start out by admitting up front that I was unable to hear all of the papers presented. That arises from the fact that on Tuesday evening I was conducting an auto census of the owls of the forests of northern Minnesota, eastern North Dakota, and southern Manitoba. I selected a strip transect to sample the area and the strip consisted of a band starting at the Minneapolis/St. Paul Airport and ending at the Viscount Gort Hotel in Winnipeg, Manitoba, Canada. I choose 100 meters from the center of the motor car route on either side of routes 494, 94, and 49 as the specific sampling area. The dimensions of the sampling plot are actually 300 kilometers by 200 meters. Admittedly only the shelterbelts and riparian woodland were suitable habitat and I must subtract 12 kilometers of the strip where dense fog, associated with sugar beet refineries, prevented my seeing any owls. Unfortunately I did not see a single owl within the study area. The only good aspect of that fact is I do not have to ponder which statistic is most appropriate to apply to my results. All of this is offered as the reason underlying my sleeping Wednesday morning when I should have been listening to papers.

Secondly, I would like to define some of the technical terms that have been used at the conference for the benefit of those readers of the proceedings. Some of these terms are similar to terms used in everyday language, but they have special meaning here, thus I shall gloss them. I shall take the terms in alphabetical order. The first term is Bastard and this has to do with mixed ancestry. Now this was not the actual term used by the presenter and when I talked with him about my using the term he suggested that it perhaps had a negative connotation. So to avoid that possibility I shall use that term Complication. We saw how Strix aluco and Strix uralensis were equally implicated in complicating the ancestry of certain generations in Bavaria. Next we have Divorce which is used to refer to the dissolution of pair bonding between mates. This was used to define bonding between individuals of the same two species earlier mentioned. Then we have Secondary Females. In the human condition this might be thought of as being analogous to playing second violin in an orchestra. We saw how "playing second fiddle" has inherent risks within Surnia ulula populations. Finally we have the term Topless and when applied to the human condition this may mean that the upper portion of the torso is unadorned of garments or is naked. Here specifically it refers to the torso of a nest cavity box being naked of a roof. Enough of that--let me now try to be serious for a few minutes.

First allow me to summarize the geographic location of the researchers. This information was taken from the official list of registrants. I have deviated from that list only insofar as I have recorded Dr. Heimo Mikkola as a resident of Finland rather than Indonesia as suggested by the list. I will play the numbers game for just a moment by saying that of the 150 registrants 22 (15%) were from eight European countries, 83 (53%) were from five Canadian provinces and one Territory and 45 (30%) were from 17 states of the United States. Norway, Finland and Sweden topped the list for numbers of participants from Europe and not surprisingly Manitoba and Saskatchewan provided the largest numbers from Canada while Minnesota, Wisconsin, Colorado and Oregon were the home states providing the largest numbers from the United States.

This says nothing about the quality of the presentations which were overall splendid from all countries. It was especially heartening to hear from Spain, Hungary, Czechoslovakia, and the USSR

even though our colleagues from the latter three countries were unable to travel to the symposium. I trust the readers are aware of the solid contributions from Scandinavia and West Germany and my comments citing specifically representation from these countries will not offend those from other countries. While humans recognize political borders, owls do not; hence, it is important to hear from researchers from all geographic locales within owl species distributional ranges.

I will now shift my emphasis to where it most appropriately belongs--to the owls themselves. I have, from the abstracts, compiled the following data [see Table 1] on a species by species basis and would caution that this compilation was done while watching slides and listening to presenters, hence must be considered a preliminary to the final report that will appear in the Proceedings. For emphasis, I will start by pointing out that seven of the 22 species targeted (perhaps a bad choice of words) selected to be the subject of this conference were not reported on at all. It is not at all surprising that five of the seven are species of Otus for 32 of the 136 species of owls commonly recognized are of the Genus Otus. They are, to enumerate, Otus kennicotti the Western Screech-Owl, Otus bakkamoena the Collared Scops-Owl of Asia, Otus brucei the Striated Scops-Owl [also of Asia] Otus scops the Common Scops-Owl of Africa, Eurasia and Indonesia and Otus sunia the Oriental Scops-Owl. In addition, we have heard nothing about Blakiston's Fish Owl Ketupa blakistoni of Japan and Korea nor Ninox scutulata the Oriental Hawk Owl which is widespread in Asia and Indonesia. Lest one think I am totally negative I would hasten to add that this conference has brought from obscurity some of the basic biology of Otus flammeolus the Flammulated Screech Owl, and its distribution on the periphery of its range in British Columbia and the same can be said about the population of Spotted Owls Strix occidentalis in that same province. Eighteen papers dealt with aspects of the basic behavior of species and we saw how techniques of hybridization, which can be an essential tool for isolating details on the genetic component of species-specific behaviors can be utilized with owl species. Food habits are always going to be an important aspect of predator studies; however they have reached the point where they are now well enough known on some species that they are now a means to the end of elucidating ecological relationships rather than being an end in themselves. Twelve

Table 1.--Summary of symposium papers; subject species, topic(s) and geographic location(s).

	ANATOMY	DISTRIBUTION	BASIC BEHAVIOR	FOOD HABITS	HABITAT	NESTING BIOLOGY	POPULATIONS	RADIO-TELEMETRY USED	TAPE-PLAYBACK USED	TOTAL NO. OF STUDIES REPORTING	GEOGRAPHIC LOCATION
Flammulated Owl ¹		1	2		1	1	1			4	BrC, Co
Eastern Screech-Owl		1	2	1	2		1	1	4	5	MI, CT, Sas
Western Screech-Owl										1	Literature Mentioned
Common Scops-Owl										1	Literature Mentioned
Striated Scops-Owl										1	Literature Mentioned
Oriental Scops-Owl										1	Literature Mentioned
Collared Scops-Owl										1	Literature Mentioned
European Eagle-Owl				1				1		3	Norwa, Spain
Great Horned Owl	3				1	1	1			7	Alb, MI, MT, Sas
Blakiston's Fish Owl										1	Literature Mentioned
Northern Hawk-Owl	2		4	1	1	4		1		8	Alb, Finla, Norwa (2), Ont, Sas
Northern Pygmy-Owl	1									2	Alb
Eurasian Pygmy-Owl			1	1					1	3	Norwa, Swede
Oriental Hawk Owl										1	Literature Mentioned
Barred Owl	2		1		5	2		2	1	9	MI, MN (2), NJ, Sas, WA
Spotted Owl		1	2		1	2		2	1	3	BrC, OR, WA
Great Gray Owl	2	2	1	5	7	4	2	3		12	AK, CA, Finla (2), Man(3), MI, MN, OR, Sas
Tawny Owl			1	3	2	1				4	Finla, Germa(W), Spain
Ural Owl			2	1	1	1		1		3	Finla, Germa(W)
Long-eared Owl	3		1							5	MN, USSRu
Boreal or Tengmalm's Owl	4	3	5	1	5	3	1	2	1	14	CO(2), Finla, MT, Norwa, Sas, Swede, WA, WI
Northern Saw-Whet Owl	3		2	2	4	1	1	1	1	9	Alb, BrC, CO, MI, MN, MT, Sas, WI

¹ See Northern Forest Owl subject species list for scientific binomials.

Location Legend: the following "abbreviation" scheme was used for reporting the location for each respective study--Canada [a three letter abbreviation for the Province or Territory], International [a five letter abbreviation for the country], United States [the standard two letter U.S. postal abbreviation].

papers dealt with the habitat of owl species in some detail and hopefully this area of research will expand from here, for a suitable place to live is no doubt even more critical to the survival of owl species than it is to man. I did not tally man-owl aspects and they were not here emphasized, however, we did see that there are some areas that are the cause for concern particularly with regard to species of Bubo. With regard to Bubo there is some good news and some bad. The good news is that through the dedicated efforts of an individual and his wife a cadre of volunteers was developed which changed the image of the Great Horned Owl in central Canada, while in Europe man continues to be a threat to the survival of the Eagle Owl, either directly through his activities or indirectly through his anthropogenic structures. The basic biology of nesting and population dynamics have been reported but there is certainly room for more research in these areas. The latter aspect is particularly crucial if we are to insure the survival of existing species that are rare, threatened or endangered and also if we are to manage species that are common, in a manner that will minimize conflict with man in relations with those species.

I will now turn to some broader aspects of the research that has been reported here as well as some points that have been made in discussion. I view **basic research, applied research, and conservation** as seen in this triangle [Figure 1]. You will note that I have represented basic research as the foundation for this triangle, i.e., it must necessarily form the basis for sound applied research and/or effective conservation and management of owl species. As one can see in the triangle basic research forms a connection to both applied research and conservation. Thus the material from these proceedings contributes either directly or indirectly to all aspects of owls. Put another way, even though a particular contribution may deal only with basic research it can potentially impact work of land managers, wildlife specialists, conservationists, and others if they will make use of it.

One cannot only find much information in the content of the individual contributions but in the literature cited at the ends of the articles as well.

I would remind you that owls are a unique group of birds that are without equals in the specializations that they have evolved, enabling them to survive in a world of darkness. Our plenary speaker elaborated on that most thoroughly. I



Figure 1.--The pyramid of sound wildlife management. Basic research must form the foundation for management of either species or communities.

must qualify that, with regard to their surviving in darkness, having worked mostly on Asio flammeus a species that can be seen active either day or night, by pointing out that while there are some owl species that are very diurnal these are the exceptions rather than the rule. Owls represent only about 1.5% of all bird species thus reinforcing the idea that owls are unique and special. Because they have invaded a realm that is foreign to the diurnal humans they have been neglected with respect to being subject for study. Although they currently enjoy popularity amongst humans with their images being collected as statues, photographs, paintings, etc., they have been both dammed and deified in the millennia that they and man have coexisted. Because they operate in a world where man is in the dark, special techniques, apparatus, etc., are required to study them. We have seen techniques using light from the infrared portion of the EM spectrum. Perhaps light in the red segment of the visible light spectrum could also be used at least for some species. Also perhaps instruments that intensify available light, the so-called Starscopes, could be used, e.g., to minimize the risk of conducting direct observations from close range on the less timid species. Certainly radio telemetry, as we have seen at this conference, has played a key role in revealing some of the secrets that we have heard about here. No doubt it will play an even greater role in the future as the telemetry technology develops further, e.g., smaller species may be studied as smaller, lighter radios are developed. Lighter radios will also allow

tracing the migration routes, times, etc. of those species whose movements appear to be somewhat erratic in nature as well as the regular migrant species and perhaps satellite tracking would be most appropriate for some of these studies.

We have seen a number of different methods used in trapping owls [see the workshop presentations for details of numerous methodologies appropriate for owl research], some of them variations of techniques used on the diurnal raptors, i.e., hawks, falcons, etc., and some unique to owls. Successful trapping of owls is critical to many types of studies and I could not overemphasize the necessity of having known individuals while studying the basic ethology of the species in the field. At this point I will site a quote from Larry McKeever's new book "A dowry of owls"

Better one bird in hand than ten in
the wood.
Better for birders, but for birds not
so good"

I am sure those of you who have tried to trap owls can relate to this and would suggest that for the latter portion that depends on the professionalism of the biologist and the use that information gleaned as a result of the trapping is put to.

Management techniques have necessarily brought in habitat management. We are, I think, observing a shift in emphasis in management from the species to the community or even to the ecosystem. However, that shift in emphasis has yet to reach owl biologists [if the biologists are not looking at wildlife from that point of view how can conservationists and wildlife managers, as well as land managers, be expected to adopt that point of view?] for of 52 papers, 39 dealt with research on a single species, four dealt with two species and while there were seven papers dealing with more than two species only three of those dealt with community studies of owls. There may be occasions when the species approach is the only way

to go, e.g., in the case of endangered species [even in those cases the species does not exist in a biological vacuum but is interrelated with other species], but a more balanced approach is that of managing an ecosystem or segment of it. As we get a better picture of the detailed habitat needs of species we are learning that absolute minimum area dimensions for species are not the only thing required for management. We must know the quality of the habitat and, in many cases the configuration of the habitat is also crucial. This poses some interesting challenges for applied research, e. g., will a habitat segment with corridors leading from it to other tracts suffice with equal satisfaction to that of a larger intact area? Such points of view and questions are going to require manager-researcher teams for they require the expertise of specialists. The list of participants of this symposium identifies a good number of the owl experts [both professional biologists and serious amateurs doing professional calibre work] and hopefully these Proceedings will carry the challenge to those in a management position that deal with owls within the domain of areas that they manage!

We do not have reason to be complacent about our knowledge for any species of owl. This conference will however, I think, be viewed as a landmark in the history of owl biology for it [along with the symposium on owls held in Sacramento in the fall of 1985, and the paper session on rare owls at the World Conference on Birds of Prey to be held in Eilat, Israel on 22-27 March 1987] will go a long way toward identifying owls as a unique group of wildlife and owl researchers as being unique in their own "light." There has been considerable discussion about following up this symposium with another in two or three years with suggestions that it deal potentially with any of the owl species and that it be held in a locale that would attract biologists from parts of the world that have been much under-represented at this symposia, e. g., eastern Europe and Asia.

Evolution, Structure, and Ecology of Northern Forest Owls¹

R. Åke Norberg²

Abstract — In this introductory survey of northern forest owls I explore what distinguishes them structurally, ecologically, and energetically; what particular ecological conditions they are subjected to; and what selection pressures govern their evolution. Comparisons are made between communities of northern forest owls in the Old World and the New World; and between northern forest owl communities and more southern ones.

Forest owls, like most forest birds - and forest bats as well - have relatively short and broad wings, which are adapted for flight among vegetation. Their wing loading is low, which facilitates transportation of prey and also reduces the wings' aerodynamic noise.

Reversed sexual size dimorphism is very pronounced in some species of northern forest owls. But theories of this phenomenon must also explain the same dimorphism in tropical owls and in diurnal birds of prey, and must also be compatible with some notable exceptions from the general rule. These problems have often been ignored.

Forest owls are primarily "searchers" in the sense that they spend most of their hunting time searching for prey and little time pursuing and capturing them. They are "perch-and-pounce" hunters, but perch height, giving-up time, and flight length vary with sensory capacities, prey density, vegetation structure, and weather - aspects treated by optimal foraging theory.

Particular attention is given to the evolution of asymmetry of the external ears in some owls. Habitat choice, vegetation structure, and hunting technique dictate to what extent vision and hearing can be used for detection and localization of prey. Hearing is particularly useful in dense forest and for detection and localization of prey moving in dense ground vegetation or under snow. When an owl depends heavily on hearing for prey finding, demands on accurate vertical localization cause selection for vertical asymmetry of the external ears. But ear asymmetry results in conflicting auditory information at the two ears. This may require a "training period", with extensive head tiltings, in young owls before they can fully benefit from the ear asymmetry.

Interactions between owl populations and populations of small mammals are considered both in the ecological and evolutionary time scale. Owls specialized on small rodents tend to destabilize rodent population cycles, while generalized owls have a stabilizing effect, suppressing prey fluctuations. Both types of owls tend to synchronize population fluctuations of small rodents and other prey animals, both locally and over larger geographic areas. Rodent cycles give rise to different behavioral strategies in owls depending on their habitat choice, dietary specialization, hunting mode, sensory capabilities, and nesting habit.

1. INTRODUCTION

This symposium on the biology of northern forest owls was restricted from the outset to include only forest owls occurring partly or entirely north of latitude 35° North. As a brief remembrancer of

geography, 35°N is 11.5° N of the Tropic of Cancer which is at 23.5° N. The 35° N latitude crosses USA through southern California, central Arkansas, and the southern part of North Carolina. In the Old World it passes through the northernmost corner of Africa, through the Mediterranean Sea, just south of the Caspian Sea, through northern Tibet, and across central Japan. Any species occurring wholly below this 35° N latitude has not been considered a "northern forest owl".

By this criterion 22 owl species will be included (table 1). But apart from a brief mention below in a survey of owl distribution, some of these species are not treated further in any of the symposium contributions.

¹Paper presented at the symposium, Biology and Conservation of Northern Forest Owls, Feb. 3-7, 1987, Winnipeg, Manitoba. USDA Forest Service General Technical Report RM-142.

²R. Åke Norberg, Department of Zoology, University of Göteborg, Box 250 59, S-400 31 Göteborg, Sweden.

CONTENTS

1. INTRODUCTION
2. DISTRIBUTION OF NORTHERN FOREST OWLS
 - 2.1. A survey
 - 2.2. Conclusion and discussion
3. COLOUR MORPHISM
4. GEOGRAPHIC VARIATION IN COLOUR
5. GENERAL SHAPE AND FORM OF FOREST OWLS
 - 5.1. Body form
 - 5.2. Head size and shape
 - 5.3. Ear tufts
6. WING SIZE AND SHAPE
7. SILENT FLIGHT - DAMPING OF AERODYNAMIC NOISE
8. REVERSED SEXUAL SIZE DIMORPHISM
 - 8.1. Introduction
 - 8.2. Ecological theory
 - 8.3. Sexual selection theory
9. HUNTING MODE
10. EYES AND VISION
11. THE FUNCTION OF EAR ASYMMETRY IN OWLS - "ONE OF THOSE ENIGMAS IN ZOÖLOGY NOT TO BE SOLVED THROUGH THE RESEARCHES OF MAN"
 - 11.1. History
 - 11.2. Theories
 - 11.2.1. Stresemann (1934)
 - 11.2.2. Pumphrey (1948)
 - 11.2.3. Payne (1962)
 - 11.2.4. Norberg (1968); "The Pumphrey-Norberg theory"
 - 11.3. Head and ear size
 - 11.4. Sound localization with symmetrical ears
 - 11.5. Head tilting in young owls with asymmetrical ears
12. EVOLUTION OF EAR ASYMMETRY
 - 12.1. The origin of ear asymmetry
 - 12.2. Convergent evolution of ear asymmetry
13. OWLS AND PREY CYCLES
14. ADAPTATIONS AMONG NORTHERN FOREST OWLS
15. THE GREAT GREY OWL
16. EPILOGUE
17. LITERATURE CITED

Next I explore what distinguishes them structurally, ecologically, and energetically; what particular ecological conditions they are subjected to, and what selection pressures govern their evolution. I particularly consider various adaptations in owls for prey capture.

"Reversed sexual size dimorphism" is very pronounced in some species of northern forest owls, and I discuss this phenomenon in relation to the same dimorphism in tropical owls and in relation also to some notable exceptions among owls, which exhibit "normal sexual size dimorphism".

Forest owls are primarily "perch-and-pounce" hunters, and I consider their hunting modes in relation to optimal foraging theory.

Since asymmetry of the external ears is very common among northern forest owls, I pay particular attention to the function of ear asymmetry and to the evolution of ear asymmetry among owls in general. I particularly consider the ecological conditions promoting the evolutionary origin of ear asymmetry.

Interactions between owl populations and populations of small mammals are considered both in the ecological and evolutionary time scale.

Table 1. — The 22 species considered as northern forest owls in this "Northern Forest Owl Symposium". All species occur partly or entirely north of latitude 35° N. Species with asymmetrical external ears are denoted by *.

NORTH AMERICA	EUROPE	ASIA
<i>Otus flammeolus</i> Flammulated Owl	—	—
<i>Otus asio</i> Eastern Screech-Owl	—	—
<i>Otus kennicotti</i> Western Screech-Owl	—	—
—	<i>Otus scops</i> European Scops-owl	<i>Otus scops</i> European Scops-owl
—	—	<i>Otus brucei</i> Striated Scops-Owl
—	—	<i>Otus sunia</i> Oriental Scops-Owl
—	—	<i>Otus bakkamoena</i> Collared Scops-Owl
—	<i>Bubo bubo</i> * European Eagle-Owl	<i>Bubo bubo</i> * European Eagle-Owl
<i>Bubo virginianus</i> Great Horned Owl	—	—
—	—	<i>Ketupa blakistoni</i> Blakiston's Fish Owl
<i>Surnia ulula</i> Northern Hawk-Owl	<i>Surnia ulula</i> Northern Hawk-Owl	<i>Surnia ulula</i> Northern Hawk-Owl
<i>Glaucidium gnoma</i> Northern Pygmy-Owl	—	—
—	<i>Glaucidium passerinum</i> Eurasian Pygmy-Owl	<i>Glaucidium passerinum</i> Eurasian Pygmy-Owl
—	—	<i>Ninox scutulata</i> Oriental Hawk Owl
<i>Strix varia</i> * Barred Owl	—	—
<i>Strix occidentalis</i> * Spotted Owl	—	—
<i>Strix nebulosa</i> * Great Gray Owl	<i>Strix nebulosa</i> * Great Gray Owl	<i>Strix nebulosa</i> * Great Gray Owl
—	<i>Strix aluco</i> * Tawny Owl	<i>Strix aluco</i> * Tawny Owl
—	<i>Strix uralensis</i> * Ural Owl	<i>Strix uralensis</i> * Ural Owl
<i>Asio otus</i> * Long-eared Owl	<i>Asio otus</i> * Long-eared Owl	<i>Asio otus</i> * Long-eared Owl
<i>Aegolius funereus</i> * Boreal or Tengmalm's Owl	<i>Aegolius funereus</i> * Boreal or Tengmalm's Owl	<i>Aegolius funereus</i> * Boreal or Tengmalm's Owl
<i>Aegolius acadicus</i> * Northern Saw-Whet Owl	—	—
12 (6 *)	9 (6 *)	14 (6 *)
← 4 (3 *) in common →		← 9 (6 *) in common →
← 4 (3 *) in common →		

I will open this introductory paper by a survey of the distribution of these 22 northern forest owls in North America, Europe, and Asia (table 1). Comparisons are made between communities of northern forest owls in the Old World and the New World.

Particular attention is given to rodent cycles and to the stabilizing and destabilizing influence of predation by generalized and specialized predators, respectively. Moreover, I consider the tendency that owl predation may have to synchronize population fluctuations among small rodents and other prey animals.

Throughout this introductory paper I will give some historical background to the various topics considered, and in particular to the historical development of new ideas and concepts.

2. DISTRIBUTION OF NORTHERN FOREST OWLS

2.1. A survey

The distribution of the 22 northern forest owls in North America, Europe, and Asia is summarized in table 1. It is based on Peters (1940) and Burton (1973). The "Working Bibliography of Owls of the World" by Clark, Smith, and Kelso (1978) also contains information on systematics and distribution. And this book is indispensable for all work on owl biology.

I will now survey the different species and make a brief comparison between communities of northern forest owls in the Old World and the New World.

There are three *Otus* species in North America, only one in Europe, and four in Asia. The flammulated scops owl *O. flammeolus* ranges through western North America down to Central America. It is closely related to the European and oriental scops owls, *O. scops* and *O. sunia* (all three of which are sometimes regarded as conspecifics; Hekstra 1973, p. 108). In North America, the eastern screech owl, *O. asio*, lives to the east of the Rocky Mountains, and the western screech owl, *O. kennicotti*, to the west of the Rockies. They are very closely related, interbreed locally (for instance in the Big Bend region of Texas, Marshall 1967, p. 3; Hekstra 1973, p. 101), and are sometimes considered to be conspecific. They are then referred to as *Otus asio*, the common screech owl, with the western population as a subspecies, *O. asio kennicottii* (Peterson 1961).

Among the four Old World *Otus* species considered here, *O. scops*, *O. brucei*, and *O. sunia* are all closely related, and are sometimes considered to be conspecific - and closely related to them is also the North American *O. flammeolus*, as mentioned above (Hekstra 1973, pp. 106, 108). The Old World collared scops-owl, *O. bakkamoena*, occurs in southeastern Asia up to about latitude 54° N. In a recent study of the territorial calls and of the wing of *Otus* owls in Pakistan, including *O. scops*, *O. brucei*, *O. sunia*, and *O. bakkamoena*, it was concluded that all four are indeed good species (Roberts and King 1986). The *Otus* owls thus constitute several species

groups whose systematics is difficult, and there has been considerable confusion concerning the taxonomic relationships of these owls. Geographic variation is extreme among screech-owls, and their coloration is complicated and has resulted from parallel and convergent evolution. Systematic treatments are given by Marshall (1967; 1978) and by Hekstra (1973).

Insects form the main diet of the *Otus* owls, and as a result most populations occurring north of the palm-limit are migratory. Exceptional in this respect is the common screech owl, *O. asio*, which is essentially resident throughout winter even in Canada, and then switches to non-insect prey like small mammals and birds. By contrast, the common scops owl, *O. scops*, in Siberia migrates about 7000 km south-east to Ethiopia (Hekstra 1973, p. 106), and mid-paleartic populations from 45-90° E, for instance from Mongolia, winter in Africa, south of Sahara (Moreau 1972, pp. 13, 194).

The Eurasian Eagle Owl *Bubo bubo* is a huge owl, the largest of all owls in the world. The weight of European owls is 2.2 - 4.0 kg for females (average 3.056) and 1.6 - 3.0 kg for males (average 2.275; Mikkola 1983). From these average weights of the two sexes, the overall average becomes 2.666 kg. This is twice as much as the mass of its American counterpart *Bubo virginianus*, which weighs only 1.309 kg (Mueller 1986, p.392).

Bubo virginianus relies heavily on the snow-shoe hare (=varying hare), *Lepus americanus*, for food. With its weight of 1.5 kg the snow-shoe hare is only about half as big as the European hares *Lepus timidus*, ca. 3 kg, and *Lepus europaeus*, ca. 4 kg. Likewise, the Canadian lynx, *Lynx canadensis*, and the smaller bobcat, *Lynx rufus*, which are other North American hare predators, weigh only about half as much as the European lynx, *Lynx lynx*. This suggests that the difference in size of the hares between North America and Europe has had some effect on the difference in size between the North American and the European *Bubo* owls and the lynx. But with *Bubo virginianus* the underlying causes must be more complex since it has a wide distribution throughout most of North and South America; therefore, insofar as size of the main prey selects for predator size, other prey than the snow-shoe hare must have affected the size of *Bubo virginianus* over a large proportion of its range.

Blakiston's Fish Owl, *Ketupa blakistoni*, is resident throughout the year in the boreal forest in eastern Asia. Its range extends up to latitude 60° N. There it occurs at streams and rivers that are so fast-flowing that they remain partially unfrozen throughout the winter. *Ketupa blakistoni* is the only fish owl with fully feathered legs, a feature undoubtedly associated with its northern distribution (Fogden, 1973, p. 68).

Leaving northern forest owl aside for a moment,

I will comment briefly on the world distribution of fishing owls. There are four species of *Ketupa* in Asia. They all have ear tufts and resemble *Bubo* owls. And in Africa there are three species of fish-owls of the genus *Scotopelia*. They lack ear tufts, and except for their specializations in common with *Ketupa* for eating fish, they are quite different in general appearance from the *Ketupa* owls. Nonetheless, owls from the two genera are believed to have their fish-catching specializations from a common ancestor rather than as a result of convergent evolution (Fogden 1973).

It is strange that there are no fish owls in the New World. There are a few species of fish-eating bats in tropical America, and it has been suggested that the presence of fish-eating bats has prevented fish owls from invading the New World or evolving there (Fogden 1973, p. 61). Let us examine this possibility in some detail.

So far, there are only five fish-eating bats known in the world (U. M. Norberg and Rayner 1987, who give further references). Australia has one, *Myotis adversus*, with mass 10.3 g. The European *Myotis daubentoni*, with mass 7.0 g, is mainly insectivorous, but has been reported to feed also on fish. The remaining three fish-eating bats have obvious adaptations in the wing and hind foot for fish-catching (U. M. Norberg and Rayner 1987). Among these, *Pizonyx vivesi*, mass 25 g, has a limited range on the southwestern part of the North American continent - in Baja California and Sonora, Mexico (Walker 1964). *Noctilio leporinus*, mass 59 g, ranges from Mexico southward to northern Argentina and Brazil, and *Noctilio labialis* (= *N. albiventris*) mass 30 g, occurs from Central America southward to Argentina. All five belong to the suborder Microchiroptera but are of mixed phylogenetic origins within it, with the genera *Myotis* and *Pizonyx* belonging to the family Vespertilionidae, and *Noctilio* to family Noctilionidae. Convergent evolution in behaviour and structure to fish-eating has obviously occurred among the fish-eating bats.

Even though the two South American fish-eating bats are larger than all the others, they are still very small by fish-owl standards and so take small fish, probably not heavier than about 50% of the mass of the bat, i.e. 30 g at most. It therefore seems obvious that the fish-eating bats cannot have constituted any competitive hindrance to an evolutionary origin of fish owls in the New World. The absence of fish owls from the New World thus seems to be one of those evolutionary results due to chance only; fish owls just have not happened to evolve in the New World, for no particular reason. An analogy among bats is the absence of blood-eating bats everywhere except from tropical America, where there are three species, each in a monotypic genus,

Desmodus rotundus, *Diaemus youngi*, and *Diphylla ecaudata* (Walker 1964).

The northern hawk owl, *Surnia ulula*, is circumboreal. It occurs along a broad zone of the northern coniferous forest, just beneath the edge of the arctic tundra, and ranges around the whole of the northern hemisphere. It hunts predominantly by eye and therefore depends on forests where the trees are widely spaced. This may be one reason for its northern distribution and for its choice of regions at high elevations above the sea level; forests on such ground are open and the coniferous trees are usually widely spaced and have typically narrow crowns, permitting good view of the forest floor.

The American pygmy-owl, *Glaucidium gnoma*, is very similar to the Eurasian pygmy-owl, *G. passerinum*, and is sometimes even considered conspecific with it (Ginn 1973, p. 178). *G. gnoma* has an elongated distributional range in the north-south direction, and occurs in western America, from southernmost Alaska southward to Guatemala in Central America. *G. passerinum* also occurs along an elongated distributional band but with an east-west orientation and a width of 600 to 1000 km.

Strix varia and *S. occidentalis* are two exclusively New World *Strix* species, which are confined to North America except for *S. varia*, whose range extends southward into Central America. They have largely non-overlapping ranges, extended in the north-south direction, *S. varia* occurring to the east, and *S. occidentalis* to the west of the Rocky Mountains. *S. occidentalis* has a strong preference for unlogged forests of mature or old-growth conifers more than 200 years old, forming uneven-aged, multilayered canopies with closures of 65-80% (Forsman, Meslow, and Wight 1984, p. 16).

Strix nebulosa is circumboreal occupying much the same range as does the hawk owl, *Surnia ulula*. *S. nebulosa* is the largest of all *Strix* owls, and in North America as well as in Eurasia its distribution is north to those of the other *Strix* species. In North America its distribution overlaps only the northernmost parts of the ranges of *S. varia* and *S. occidentalis*.

In the Old World, *S. aluco* and *S. uralensis* are ecological equivalents to *S. varia* and *S. occidentalis* in North America. But in Eurasia the ranges of all three *Strix* owls are extended in the east-west direction and ordered from north to south with the largest one, *S. nebulosa*, furthest to the north, followed in latitudinal range by the medium-sized ural owl, *S. uralensis*, and then by the smaller tawny owl, *S. aluco*, furthest to the south. This is a fairly orderly pattern even though there is considerable overlap between the ranges of *S. nebulosa* and *S. uralensis*, and rather less overlap between *S. uralensis* and *S. aluco* (Svårdson 1949; Lundberg 1980).

The Eurasian *S. uralensis* and *S. aluco* are two closely related but very well defined species of markedly different sizes and with essentially non-overlapping ranges, as described above; *S. uralensis* (female mass 871 g, male mass 720g) occupies mainly the coniferous taiga and *S. aluco* (mass 583 g and 474 g; Mikkola 1983, p. 377) occurs further south in semi-open and open deciduous woodland. But after crossing a female *S. aluco* with a male *S. uralensis* in captivity, Scherzinger (1983) made the remarkable discovery that fertile eggs were produced and even gave rise to two viable young, a female and a male. The F₁ hybrid progeny exhibited a mosaic of characters from their parent species as regards size, coloration, and vocalization, the overall result therefore being truly intermediate. The male and female hybrid siblings did not produce any eggs during the two years they shared cage, but the hybrid male later gave rise to viable F₂ birds in back-crosses with both parent species, with *S. aluco* as well as with *S. uralensis*.

The long-eared owl, *Asio otus*, is circumboreal with a range extending across North America and Eurasia in a broad belt essentially south of the range of the hawk owl, *Surnia ulula*.

The boreal owl (North American name), or Tengmalm's owl (European name), *Aegolius funereus*, is circumboreal and occurs in a wide belt of the northern coniferous forest, beginning as far north as the hawk-owl's range, but extending much farther south. The range of the smaller saw-whet owl, *Aegolius acadicus*, is strictly limited to North America (unless the Central American *Aegolius ridgwayi* will prove eventually to be merely a subspecies of *A. acadicus*). *A. acadicus* occurs essentially south of the range of *A. funereus*, but there is a zone of overlap along the Canadian-USA border. Despite the more southern range of *A. acadicus*, northern populations of it are more migratory than is *A. funereus*. The latter performs irregular, irruptive, movements only, in North America as well as in the Palearctic.

2.2. Conclusion and discussion

As will have been apparent, the northern forest owl faunas in North America, Europe, and Asia are remarkably similar in their overall composition (table 1).

Four species are circumboreal and occur in all three regions, viz. *Surnia ulula*, *Strix nebulosa*, *Asio otus*, and *Aegolius funereus*.

There are three *Otus* owls in North America, one in Europe, and four in Asia, and none of these occurs both in North America and Eurasia.

Bubo and *Glaucidium* both have a different representative in North America and in Eurasia, and there is a remarkable size difference between the two *Bubo* species.

The fish-owl *Ketupa blakistoni* occurs only in Asia, and the total absence of fish-owls from the New World has no obvious ecological explanation, but is probably the result of chance only; simply that no fish owls did ever evolve in the New World. One possibility in terms of ecological explanation could be if *Bubo virginianus*, which is a generalized owl with a very wide diet, does take fish to the extent that it fills the prospective niche of any fish owl.

Strix nebulosa is shared between all three regions, while there is a different set of two additional, *Strix* species in North America and Eurasia, *S. varia* and *S. occidentalis* versus *S. aluco* and *S. uralensis*, all four of which are structurally and ecologically similar.

Finally, *Aegolius funereus* occurs in all three regions, whereas *A. acadicus* is unique to North America. The reason why North America has two *Aegolius* species, and Eurasia only one, may be that *Aegolius* probably evolved in the New World. My reason for believing this is that there are four *Aegolius* species in the New World as opposed to only one in Eurasia; *A. funereus* and *A. acadicus* in North America, *A. ridgwayi* in Central America, and *A. harrisii* in South America, but only *A. funereus* in Eurasia.

The distributional patterns of *Strix* owls in Eurasia and *Aegolius* owls in North America thus are in accordance with Bergmann's ecogeographic rule, the tendency for body size in homeotherms to be negatively correlated with environmental temperatures, i. e. for body size to be larger where temperature is lower. This trend may be expected for the distribution of populations of differently sized animals of the same species (fig. 1), or for the distribution of differently sized species that are closely related and ecologically similar (as with the *Strix* and *Aegolius* species).

Among the 124 (or so) species of owls in the world, 42 species - or 34% - have asymmetrical external ears. Among the 22 northern forest owls recognized here, nine - or 41% - have asymmetrical external ears. They are marked with an asterisk in table 1. Among the 22 northern forest owls the proportion of species with asymmetrical ears in the three geographic regions is 50% for North America, 67% for Europe, and 43% for Asia. The percentage (41%) for all northern forest owls taken together is lower than the percentage for the owls of any of the three geographic regions taken separately. The reason is that owls with asymmetrical ears tend to occur in two or three of the geographic regions more often than do species with symmetrical ears. These large geographical ranges of species with ear asymmetry may reflect greater ecological success than for those with symmetrical ears.

The figures 50%, 67%, and 43% for the northern, regional, proportions of the number of owls with ear asymmetry are to be compared with 34% worldwide.

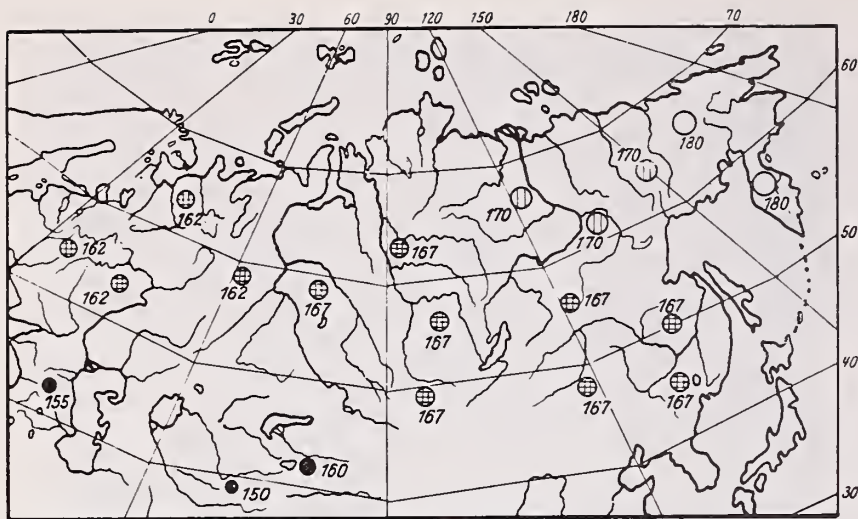

○, ⊕, ⊗, ● = Increasing darkness of plumage.

Figure 1. - Geographic variation in size and coloration in *Aegolius funereus* in the Palearctic in accord with Bergmann's and Gloger's ecogeographic rules. There is a trend of increasing size towards the north and northern owls have less plumage pigmentation than more southern ones. The length of the hand-wing is given in millimeters at the circles whose size is also proportional to wing length. The different shades of the circles symbolize plumage darkness of owls from various local populations. - From Lüers and Ulrich (1959, p. 644).

So ear asymmetry is a common characteristic among northern forest owls. Therefore I will devote some space below to explaining the function of ear asymmetry in owls, to exposing the multiple evolutionary origins of ear asymmetry, and to considering the selective forces leading to its origin.

3. COLOUR MORPHISM

Most screech-owls are dimorphic in colour (Marshall 1967, p. 1). The North American screech owl *Otus asio* (and in particular the Nevada Great Basin population *O. a. macfarlanei*; Peterson 1961) occurs in two distinct colour phases, grey and brown, but also in one or more intermediate forms.

The ecological significance of the various colour phases were recognized as early as 1893 by Hasbrouck. Based on a sample of about 3600 owls, he concluded that the frequencies of the various colour morphs are independent of age, sex, or season, but that temperature and humidity affect the frequency distribution of the various colour morphs. Martin (1950) recognized nine colour morphs in a sample of 145 owls from Canada, and, like Hasbrouck (1893), found no relationship between colour and sex.

Laurel VanCamp and Charles Henny (unpublished, cited from Mosher and Henny 1976) found overwinter survival to be higher for grey than for red *Otus asio* owls in one unusually severe winter in northern Ohio (44% more red birds dying), whereas there were no differences in normal winters. Mosher and Henny (1976) recorded oxygen

consumption at different ambient temperatures and showed that red-phase *Otus asio* had significantly higher metabolic rates at temperatures below -5°C , whereas there was a tendency for the red-phase owls to consume less energy above about 5°C . The differences may be associated with colour either directly, due to differences in plumage conductance or heat radiation, or indirectly, via fundamental physiological differences genetically linked with plumage colour.

The colours of the various morphs or phases are genetically fixed for the lifetime of the individual. The genetic basis of the colour morphs has been studied in *Otus asio*. Hrubant (1955) concluded that if three colour morphs are distinguished, the outcome of 80 matings in a population of free-living Eastern screech owls in Ohio is consistent with the inheritance via three alleles at one autosomal gene locus, and with a graded order of dominance of red over intermediate over grey.

The Old World *Strix aluco* does also occur in different colour phases, which occur together in local populations. There is a continuous gradation from extreme grey, through tawny, to red phenotypes (Kjell Wallin, Göteborg University, pers. comm.; own observations), which suggests a polygenic basis of plumage colour.

4. GEOGRAPHIC VARIATION IN COLOUR

Writing about the coloration of *Otus* owls, Marshall (1967, p. 2) emphasized its cryptic nature and the frequent evolutionary convergence in cryptic coloration. Species after species accomplish the same trends even on different continents. Where two or more species are sympatric, their coloration is almost identical. He interpreted this to be the result of strong selection from predators.

In *Otus* there are consistent geographic and climate-related trends in coloration from rich dark brown in humid areas of the north to grey in deserts and to rufous in the tropics, and they all have their blackest form at or near arid country of high altitude. The rufous phase was believed to match the colour of red-barked trees, which actually occur in the tropics (Marshall 1967, p. 2). All these colour variations were considered by Marshall to be the result of strong selection for concealment by the action of both diurnal and nocturnal predators on owls.

With reference to the differences between grey and red morphs of a single species in their metabolic energy costs at different ambient temperatures (described in the previous section; Mosher and Henny 1976), I suggest that the geographic and climate-related, intra-specific, variation in colour of locally monomorphic species is the result of local selection for minimization of metabolic energy costs for thermoregulation.

There are thus two hypotheses to explain the geographic and climate-related, intra-specific, colour trends in owls; (1) it is the result of natural selection for cryptic coloration against the prevailing local colour of bark, twigs, and leaves (Marshall 1967, p. 2), or (2) the result of natural selection for a colour that reduces the metabolic energy costs of thermoregulation under the local climate conditions. Actually, these two hypotheses need not be mutually exclusive.

Marshall (1967, pp. 2, 3) suggested that *Otus* owls are monomorphic where the colour of the vegetation is monotonous but that they occur in various colour morphs where the vegetation is varied, favouring different cryptic coloration in different localities and at different times of the year. Likewise, it might be argued that if the colour is selected to minimize thermoregulatory metabolic energy costs, monomorphism may occur where climatic conditions are stable whereas polymorphism is favoured where there are large local and temporal variations in climate.

These geographic colour variations are examples of a fairly general phenomenon among animals, summarized in Gloger's ecogeographical rule. This rule is based on empirical observations within species but on populations in different geographic regions. Gloger's rule states that animals in warm and humid areas are more heavily pigmented than those in cool and dry areas, and black pigments are reduced in warm dry areas, whereas brown pigments are reduced in cold humid areas (Mayr 1965, p. 324). I know of no other explanation of the rule except for (1) the crypsis and (2) the thermoregulatory hypotheses discussed above.

In Eurasia *Aegolius funereus* shows a consistent clinal trend in size and coloration in accord with Bergmann's and Gloger's rules, respectively (fig. 1; Lüers and Ulrich 1959, p. 644). Gloger's rule seems to be broadly applicable also to inter-specific comparisons of plumage colours among non-migratory northern forest owls; the northern *Strix nebulosa*, *Strix uralensis* and *Surnia ulula* are light and grey and with very little brown colour while more southern owls, like *Strix aluco* and *Asio otus* are darker and with much brown in their plumage.

5. GENERAL SHAPE AND FORM OF FOREST OWLS

5.1. Body form

Wood owls in general, and those occurring at high latitudes in particular, are very stocky, or chunky, and have a very loose, fluffy, and thick plumage (fig. 2). In this respect they differ from owls hunting largely on the wing in open country.



Figure 2. - Plumage thickness is probably the result of an energetic compromise between thermoregulation and flight. Minimization of energy cost for thermoregulation when the ambient temperature is below the bird's thermoneutral zone selects for thick plumage, while minimization of flight cost selects for thin plumage. Forest owls fly relatively little and have a thick, fluffy, plumage. This old picture shows a tawny owl, *Strix aluco*. - From Brehm (1922, Vol. 8, p. 224).

I will briefly consider the costs and benefits to owls of having a thick plumage. The main benefit must be (1) improved thermal insulation, which reduces the metabolic energy costs for thermoregulation when the ambient temperature is below the owl's thermoneutral zone. And there are two main costs, (2) the cost of growing the additional downs and feathers and (3) the extra energy cost of flight because of increased aerodynamic body drag and because of the added plumage weight, albeit small.

Points (1), (2), and (3) probably identify the most important selection forces governing plumage thickness in owls. The cost of growing a thick plumage (2) cannot profitably be compared with the other costs because they are incurred at different time periods in the bird's life. The plumage thickness actually observed in a species instead is probably the result of a compromise mainly between the conflicting demands for minimization of metabolic energy costs for thermoregulation (1) and for flight (3). The balance between these costs should be most critical in winter.

Now, for a bird that flies much, the optimum

plumage thickness is less than for a bird that flies less. But in a cold environment, the optimum plumage thickness is greater than in a warmer environment.

These predictions seem to be borne out by a comparison of different owls; those that live far to the north (cold environment) and fly little has a thick plumage, *Strix nebulosa* being an extreme example of this category, while owls that live further to the south, or that are migratory (warm environment), and fly much, for hunting and/or for migration, have a slim appearance, as for example *Asio otus* and *Asio flammeus*.

The penalty from thick feathering comes in the form of increased metabolic energy costs of flight. But forest owls do not fly very much. Therefore, the balancing selection pressures for improved thermal insulation (i.e. thick plumage) and reduced flight costs (i.e. slim plumage) balance at a rather thick plumage.

It should be noted that thick plumage is an adaptation for winter conditions. In summer it may cause difficulties for the owls getting rid of excessive heat (e.g. Barrows 1981); then gular flutter and other means of dissipating body heat consume extra energy, rather than conserving it.

5.2. Head size and shape

The owls have big heads for two good reasons; to accommodate the huge eyes, adapted for vision in poor light, and to enable the external ears to be big and to be placed far apart, both factors contributing to proficiency in sound localization (see section on hearing). And since the head is large anyway in owls (i.e. for these particular reasons), the body located aft of it in flight may as well be stocky since it does not add much to the aerodynamic drag, provided it does not extend outside the frontal projection of the head. Aerodynamic drag is determined primarily by the projected frontal, cross-sectional, body area.

Open-country owls which fly much, like *Asio otus* and *Asio flammeus*, have a slimmer appearance than forest owls; and it is not only the overall body form that is slimmer, but they also have relatively much smaller heads than the forest owls.

Diurnally hunting owls and open-country owls tend to have distinct eye-brows, whereas eye-brows are small or virtually lacking in nocturnal forest owls. For example, contrast *Surnia ulula* and *Glaucidium* with *Strix* and *Aegolius* species! The eye-brows obviously function as a protection against the glaring light from the sun, sun-lit clouds, and the open sky.

5.3. Ear tufts

Ear tufts occur in the *Otus* and *Bubo* species, in *Ketupa blakistoni* and in *Asio otus*. They function as

camouflage at the day roost; the owls usually erect the ear tufts when trying to avoid being detected and at the same time make themselves appear narrower by compressing the plumage, stretching upwards into an erect posture, and sometimes also turning its nearest shoulder towards the intruder, thus presenting a disrupted colour pattern, with the wings forming a dark region contrasting with the generally lighter breast. This is an effective way of camouflage, and the erected ear tufts likewise have a disruptive effect on the general appearance of the owl, making it blend better with the surroundings. Ear tufts are particularly common among forest owls, lending support to the camouflage hypothesis, because it is among branches and twigs that ear tufts are most effective (Perrone 1981).

But ear tufts have also been supposed to be a kind of mimicry; when erected, the ear tufts may make the owl face resemble that of a mammalian carnivore, which supposedly intimidates a prospective attacker (Myserud and Dunker 1979). The camouflage and the carnivore-mimicry hypotheses are not mutually exclusive but might well operate together.

6. WING SIZE AND SHAPE

The wing loading, which is total weight Mg divided by wing area S , is very low in owls as compared with other birds (M is mass and g is acceleration due to gravity). Since wing area scales with body mass as $M^{2/3}$ in geometrically similar birds, the wing loading Mg/S scales as $M^{1/3}$. Therefore, for geometrically similar birds, wing loading becomes larger with increasing size of bird. But the effect of size can be compensated for by calculating a "relative wing loading", which is wing loading divided by $M^{1/3}$, or $Mg/(SM^{1/3})$. And when this is done, owls are also among the birds with the lowest relative wing loading (Norberg and Norberg in press).

Any characteristic flight speed, such as the minimum power speed or the maximum range speed (identified by their characteristic locations along the U-shaped power versus speed curve) varies with the square root of the wing loading, or as $(Mg/S)^{1/2}$ (Lighthill 1977; U. M. Norberg 1985, p. 138). Because of their low wing loading, owls can fly slowly. This has two advantageous consequences: (1) owls can make sharp turns, which is useful in dense vegetation, and, because of the low relative speed of the air flow over the wings, (2) there is less tendency for aerodynamic noise to be produced, facilitating hearing while in flight and making it more difficult for prey animals to detect an approaching owl.

There are additional advantages of low wing loading to predators like owls; owing to the initially low wing loading, the loading during prey transport tends to be low also for the owl and prey combined.

This should enable the owl to fly slower during transport of prey of a given weight, therefore (3) reducing the power output during prey transport in flight and also retaining the owl's manoeuvrability, of particular importance in forest. For the same reason, given a maximum, sustainable power output, (4) the owl should be able to transport heavier prey (Norberg and Norberg in press), because with higher wing loading the flight speed would need to be higher with ensuing larger demands on power output.

Aspect ratio is an aerodynamically important measure expressing the ratio between wingspan and the average wing chord. It can be conveniently estimated in animals as wingspan b squared divided by wing area S , or b^2/S , which is wingspan divided by mean chord length c since $S = bc$. As compared with other birds, owls have wings of low aspect ratio, i. e. short and broad wings (Norberg and Norberg, in press). And among owls themselves, forest species generally have much lower aspect ratios than open-country owls. The short, broad wings of forest owls are advantageous for flight within dense vegetation for the obvious reason that the flying owl needs less space among branches and twigs, but also because such wings enhance manoeuvrability (Norberg and Norberg in press). With a short wingspan, the wing chord needs to be long for the wing loading to remain low, and this is a reason why forest owls have low aspect-ratio wings.

7. SILENT FLIGHT - DAMPING OF AERODYNAMIC NOISE

There are two reasons why owls benefit more from silent flight than would most other birds; (1) it increases the probability for an owl to approach and pounce upon a prey with acute hearing, like small mammals, without being detected acoustically; and (2) it improves the ability of the owl to detect and localize sound in flight, since flight noise would mask other sounds.

In an insightful paper in 1934, Graham saw an association between the silent flight of owls and the following three structural features of flight feathers.

(1) The leading edge comb. - There is a remarkably stiff, comb-like fringe on the front margin of every feather that functions as a leading edge. When there is a graded length of the anteriormost primary feathers, the ones behind the first feather are combed in the distal region that extends beyond the first feather (fig. 5). Likewise, where a feather is emarginated, there is a combed fringe on the new, secondary leading edge behind the slot. This comb was believed to reduce noise by its effect on the pressure distribution in the boundary layer behind the leading edge.

(2) The trailing edge fringe. - Along the trailing edge of the wing there is a very soft hair-like fringe

on the primary and secondary feathers. The barbs in the fringe are exceedingly flexible and do not form a continuous vane but are free to separate.

Silencing probably comes from the fringe's smoothening effect on the air flow at the trailing edge where the airstreams along the lower and upper wing surface mix. The stream along the ventral surface of the wing has a higher pressure and velocity than the stream over the wing. The fringe may also suppress flutter, accompanied by sound, in this region of air mixing.

(3) The downy upper surface. - The upper surface of the primary and secondary flight feathers are covered with a fine and soft velvet-like lining of short hair-like structures. It reduces the noise made by feathers sliding over one another as the wings are extended and flexed throughout the wingbeat.

Apart from these three features of owls Graham (1934, p. 843) recognized one more, in passing, namely:

(4) The generally low wing loading of owls, which enables them to maintain small angles of attack and relatively low speeds of the distal wing parts throughout the wingbeat. As a consequence, there is less opportunity for aerodynamic noise to arise as the air passes relatively slowly past the sharp leading edge of the anteriormost flight feathers. Likewise, because of the lower pressure difference between the lower and upper wing sides, there is less abrupt pressure equalization at the trailing edge of the wing and at the wingtip, entailing less noise.

Fishing owls, both *Ketupa* and *Scotopelia* (Graham 1934; Thorpe and Griffin 1962), generate flight noise and also lack the structural characteristics associated with silent flight. Thorpe and Griffin (1962) showed that the flight of owls is silenced not only in the frequency range audible to man, but also in an ultrasonic range above 15.000 Hz, again with the notable exception of the fishing owls *Ketupa* and *Scotopelia*, which produce more flight noise also in this frequency range than do other owls of similar sizes. The ears of small mammals are sensitive to such ultrasonic frequencies, so flight silencing in this region is also essential to owls, even if these frequencies are more attenuated with distance and therefore do not carry as far as does sound of lower frequencies.

Further descriptions of the silencing structures of owl feathers appear in Sick (1937, pp. 316-321), Hertel (1966), and Neuhaus, Bretting and Schweizer (1973). Neuhaus et al. (1973) and Gruschka, Borchers and Coble (1971) examined the frequency spectrum and sound pressure levels of the flight noise produced.

8. REVERSED SEXUAL SIZE DIMORPHISM

8.1. introduction

Sexual size dimorphism of the "normal" kind,

8.2. Ecological theory

with males larger than females, was explained by Darwin (1871) as a result of sexual selection favouring large males in competition over mates. "Reversed" sexual size dimorphism refers to female dominance in size. It occurs among two categories of birds. Species in one of these are characterized by having reversed roles of the sexes in pair formation, females competing for males. Therefore this size dimorphism can also be explained by sexual selection. Such species occur, for example, among Charadriidae and Scolopacidae.

The second category, which is of more concern in this paper, includes most raptors (Falconiformes), owls (Strigiformes) and skuas (Stercorariinae). In addition to the reversed sexual size dimorphism, the mates have markedly different roles during breeding in these predatory birds. The female usually incubates and later stays in or near the nest, guarding the offspring until they are more than half-grown, while the male forages for the whole family (Andersson and Norberg 1981).

The degree of dimorphism varies strongly among species, and there is a clear across-species trend with dimorphism being most pronounced in species with the largest proportion of agile prey in their diet (Earhart and Johnson 1970; Reynolds 1972; Snyder and Wiley 1976; Newton 1979, pp. 19-27). The European sparrowhawk, *Accipiter nisus*, shows a greater weight difference between the sexes than any raptor in the world, the female being 1.7-1.9 times as heavy as the male (fig. 3) (Opdam 1975; Newton 1986, p. 32). And among owls, the most pronounced size dimorphism occurs in *Aegolius funereus* and *Strix nebulosa*, in which the female is 1.38 - 1.57 times as heavy as the male (Earhart and Johnson 1970, pp. 254, 255, 259; Lundberg 1986, p. 135; Korpimäki 1986, p. 327).

The explanation of reversed sexual size dimorphism in predatory birds has been lively debated recently, and there is disagreement about the underlying causes. Reviews occur in, for instance, Newton (1979, pp. 19-27; 1986, pp. 32-34, 323-326), Andersson and Norberg (1981), Mueller and Meyer (1985), and Mueller (1986), the latter two containing extensive tests of predictions from the main hypotheses. Owls are treated in, for instance, Earhart and Johnson (1970), Snyder and Wiley (1976), and Mueller (1986).

The first and most important requirement on a theory explaining the evolutionary origin of reversed sexual size dimorphism is that it should apply to all three groups of predatory birds with reversed sexual size dimorphism, viz. to raptors, owls, and skuas; and it should be applicable in all parts of the world. It should also be able to cope with the few, but notable, exceptions to the rule, i. e. to species showing normal size dimorphism. Examples of such species among owls are the burrowing owl, *Speotyto (Athene) cunicularia*, and several owls of the genus *Ninox*.

I shall now review the basic features of an eclectic theory, with many new elements in it, presented by Andersson and Norberg (1981). They strongly emphasized the need for such a theory to provide explanations at three levels, denoted A, B, and C below and in figure 3.

A. Why is there such a marked *role partitioning* between the sexes among these birds during the breeding season?

B. What determines the *direction of the role partitioning and size dimorphism*, i. e. why does the male alone take on the role as food-provider for the whole family during most of the breeding season?

C. What determines the *degree of size dimorphism* which varies strongly among species? Andersson and Norberg also stressed that a theory must explain why the factors invoked apply more to predatory birds than to others.

The explanation presented by Andersson and Norberg (1981) is ecological, and their various arguments are numbered 1 - 15 below and in figure 3 (their paper should be consulted for references to those arguments that are from other sources). They emphasized conditions during breeding (Andersson and Norberg, 1981, their legend to figure 4); since the differences in size and behaviour are sexual, the underlying causes are probably linked to aspects of breeding and to prey choice during breeding (stressed later also by Newton, 1986, p. 33).

A. (1) Owing to their structural and behavioural adaptations for prey capture, entailing fighting 'know-how', birds of prey and skuas should be more successful than similarly sized, non-predatory birds in defending offspring. (2) When the prey are vertebrates, which have acute senses to detect predators, and when two predator mates hunt in the same territory (but without co-ordinating their search), one mate may often be searching where the other has recently alerted potential prey. Because of this interference they may not procure much more food together than would one mate alone, using systematic search.

These arguments may explain why separation of breeding duties may be particularly advantageous among predatory birds, leading to its evolution in the first place.

B. The following features may explain the direction of role partitioning and size dimorphism, i. e. why the female stays at the nest and becomes the larger sex, not the male. (3) There is a risk of damage to the developing eggs inside the female during hunts (Walter 1979); (4) the added weight during egg production reduces her flight performance in hunts; (5) the female has to visit the nest for egg laying; (9) "courtship feeding", widespread also among non-predatory birds, obviously speeds up energy accumulation by the female for egg production and also enables her to conserve energy by not hunting. -

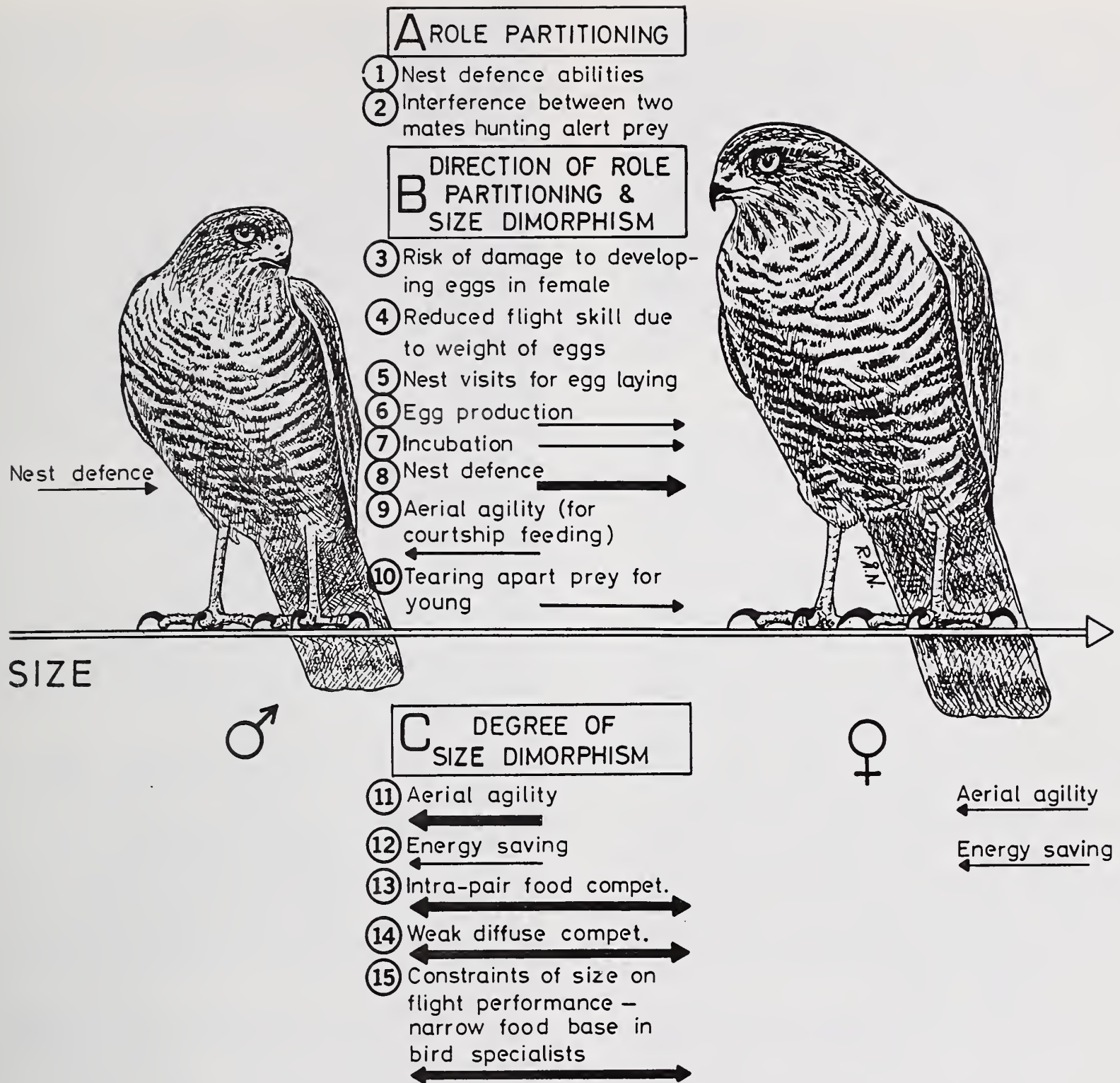

Figure 3. - Direction and relative importance (thickness of arrows) of hypothetical selection pressures that may be responsible for the sex role partitioning and reversed sexual size dimorphism among raptors, owls, and skuas. The figure shows a male and a female sparrowhawk, *Accipiter nisus*, drawn to the same scale. This Old-World hawk is the most size-dimorphic raptor in the world, the female being 1.7 - 1.9 times as heavy as the male. For this figure the weight ratio was taken to be 1.7, and assuming that geometric similarity prevails, this corresponds to the length ratio 1.2 shown. The explanation in this figure emphasizes three levels. - Modified from Andersson and Norberg (1981, p. 121).

which tends to predispose the female for the non-hunting role among birds of prey (fig. 3). These were reasons for the direction of role separation, while the following points, (6) - (10), may explain the direction of size dimorphism.

(6) Egg production, (7) incubation, (8) nest defence and (10) the dividing up of food for the young select for large female size, roles (8) and (10) probably most often falling on the female which attends the nest while the male is away hunting. And courtship feeding by the male (9) selects for small male size, but this needs some explanation.

Andersson and Norberg (1981) made a scaling analysis of six aspects of flight performance that must be crucial for hunting success. The only flight function which improves with increased predator

mass is terminal diving speed, but its dependence on mass is weak. In the other five respects a small bird does better than a larger, but geometrically similar, one. This applies to (i) maximum linear acceleration in flapping flight, (ii) maximum speed in horizontal flapping flight, (iii) maximum rate of climb in flight, (iv) maximum angular roll acceleration, and (v) turning ability, the latter two aspects governing manoeuvrability. Features i - v together should be of overriding importance, in relation to the terminal speed in dives, in determining the best predator size for hunting. By linear programming, Andersson and Norberg (1981) illustrated how this set of five flight aspects may constrain predator size, favouring small over large.

(9) Courtship feeding by the male selects for aerial agility, therefore tending towards small males.

C. The following aspects may be important for the various degrees of dimorphism in different species. The more agile the prey is, the closer the predator should approach the lower size limit below which subduing and transporting the prey become difficult. The more mammals and birds the predator takes, the stronger the selection for small size therefore becomes, given a particular size range of prey, constrained downwards and upwards by smaller and larger competing predators. (11) Since the male does most of the hunting, he is more strongly selected for small size than the female, and more so the more agile prey he takes. (12) A small male also expends less energy than a larger one, in particular among species with active hunting modes, which are associated with high energy costs for locomotion, as in predators on mammals and birds. The less energy that the male expends himself the more of the prey that he catches can be diverted to the young, which selects for small size and small fat reserves (R. Å. Norberg 1981).

(13) Intra-pair food competition should tend to drive the sizes of female and male apart. This applies in particular to bird specialists (15), which have narrow size spectra of potential prey, their food base therefore being prone to depletion. Their prey-size range is narrow because they can outfly and catch only prey birds that are large relative to themselves, whereas birds which they can outfly more easily tend to be too large for them to subdue and transport to the nest. Because of the narrow food base of each sex in predators specialized on birds as prey, such specialists thus should be subjected to particularly strong selection to alleviate intra-pair food competition by evolving a high degree of size dimorphism, which widens the combined prey base of the predator pair.

(14) Among predators on birds there should be weak 'diffuse' competition (from competitors of similar as well as of different kinds) because very few but the most specialized birds of prey can catch birds. Therefore there should be relatively little

competitive resistance against evolutionary divergence of the food-size niches of female and male among such birds, facilitating evolutionary divergence in size.

Among the various flight characteristics considered above, (i) maximum linear acceleration in flapping flight and (ii) maximum speed in horizontal flapping flight, may be of some importance to *Glaucidium* owls, which may take birds in flight, but not so much to other owls. But the two aspects that govern manoeuvrability, i. e. (iv) maximum angular roll acceleration, and (v) turning ability, should both be important for the hunting success of most owls. And this should apply in particular to forest owls, and most so to those hunting in dense forest, where good manoeuvrability in flight among vegetation is indispensable.

Indeed, sexual differences in manoeuvrability due to differences in mass and wing size may lead to sexual differences in diet and habitat utilization, small males being more able to exploit dense forest (Korpimäki 1986). Dietary differences might arise directly, from different, size-related, hunting abilities, or indirectly, from different, size-related, habitat utilizations. Females of *Strix nebulosa* and *Aegolius funereus* take larger prey than do males (Mikkola 1983, p. 378).

Since selection for manoeuvrability should be stronger in the male than in the female, because the male does most of the hunting, the degree of sexual size dimorphism in the set of characters that governs manoeuvrability should be positively correlated with the vegetation density in the hunting habitat (R. Å. Norberg in prep.). This may help explain why *Aegolius funereus* and *Strix nebulosa*, both of which fly much in dense forest, are the most size-dimorphic of all owls.

There seems to be a widespread misconception about the proportion of birds in owls' diet and their need for manoeuvrability (e. g. Lundberg 1986, p. 136); with the exception of *Glaucidium* owls, which may take birds in flight, most other owls probably take their avian prey on the night roost. This does not favour manoeuvrability as much as do aerial chases.

There is one aspect of small size among owls that might reduce hunting efficiency, namely the reduced distance between the ear openings; it leads to reduced accuracy of sound localization using time cues. Obviously there is selection to obviate this disadvantage of small male size, because in *Bubo virginianus* at least, skull width is larger in the male than in the female, whereas females are larger in all other measurements (McGillivray 1985).

The normal size dimorphism in *Speotyto (Athene) cunicularia*, with males larger than females, actually supports the Andersson- Norberg theory (1981, p.112). This owl uses open habitat

where the male can easily detect approaching predators whereas the female, from within the subterranean nest burrow, can not. It seems natural, therefore, that the male should guard and defend the nest by aerial attacks. Moreover, *Speotyto* is the only North American or Eurasian owl with colonial breeding, and it is known to engage in group defence against predators, which further reduces the need for females to be the larger sex (Mueller 1986, p. 399). This supports the nest-defence argument for role partitioning in point A:1 in figure 3. But the *Ninox* owls remain an enigma for all hypotheses on reversed sexual size dimorphism among predatory birds (Andersson and Norberg 1981, p. 120).

Lundberg (1986) focused on northern owls only, observed that the degree of dimorphism in mass is inversely correlated with environmental temperature, and argued that because cold climate and early breeding should select for large females (who do the incubation), leading to strong dimorphism, the degree of mass dimorphism is explained by the environmental temperatures. I agree this may help explain the degree of mass dimorphism. But Lundberg (1986) ignored tropical owls and raptors, as well as the exceptional species; and he did not explain why role partitioning occurs (A; fig. 3) and what determines the direction of role partitioning and size dimorphism (B), and so his hypothesis lacks the generality that any such theory must exhibit.

An additional argument by Lundberg was that because prey brought by male owls to nest-attending females are large (as compared with those of non-predatory birds), they tend to be delivered at long intervals; and under harsh and fluctuating weather conditions the intervals become unpredictable. Since large females take longer time to starve than small ones, Lundberg (1986, p. 138) thought that large female size is selected for under such conditions. But a large female needs more food than a small one, and since temporarily surplus prey are routinely stored in the nest among most owls, a small female should survive longer on given rations of food, delivered at unpredictable intervals (fig. 21).

Korpimäki (1986, p. 328, 329) observed that early breeding pairs of *Aegolius funereus* in Finland were more dimorphic in weight (but not in hand-wing length) than later breeders. Because of the "calendar effect" - clutch size decreasing with later laying date - there was a positive correlation between breeding success and weight dimorphism within the pair. Males showed much less seasonal weight change than females, but females of light and short-winged males laid eggs earlier than those with larger males.

Although a potentially interesting example of size selection, the observed trend of later laying dates by pairs composed of lighter females and heavier males might just as well have a purely ecological explanation. It is unclear whether the weight

dimorphism was due to real "size" differences, or just reflected differences in nutritional condition, females with the most fat reserves breeding earliest. Early pair formation (such as when both mates are resident throughout the winter) enables the male to feed the female for a long time before laying, increasing her weight but decreasing his, and enabling her to lay early. But late pair formation gives less time for such weight dimorphism to arise from courtship feeding and also results in late laying. Therefore, future studies should include other "size" measures than weight.

8.3. Sexual selection theory

It has been suggested that the reversed sexual size dimorphism in birds of prey may be caused by Darwinian sexual selection, similar to, but reversed in relation to that held to be responsible for the "normal sexual size dimorphism". The argument is that because males invest so much in breeding by supplying most of the food, competent males are a scarce, valuable resource, over which females compete, driving female size increase by intrasexual selection (Olsen and Olsen 1984; Newton 1986, p. 326). Mating preference, females choosing small males by their superior ability of providing food, might help increase dimorphism by intersexual selection (Cade 1982, p. 43; Safina 1984).

But I think sexual selection alone cannot explain the origin of reversed dimorphism at any of the three levels in figure 3; (A) why there is a role division in the first place, (B) why the direction of role division and size dimorphism is as observed, or (C) why there are interspecific differences in degree of dimorphism. A sexual selection explanation at level C would require systematic differences between species in the variance of male competence, or in the degree to which males invest in breeding, by food provisioning, such that both variables increase with increasing proportion of agile prey in the diet. Then the intensity of sexual selection might vary accordingly to give various degrees of dimorphism. But owls seem to be a remarkably uniform group in all relative roles of the sexes in parental care (Mueller 1986, p. 402), reducing the likelihood of this possibility.

9. HUNTING MODE

Most forest owls hunt from a perch, using a "sit-and-wait" - or "perch-and-pounce" - hunting technique (figs 4 and 5). But search for prey may be done in flight to some extent, as in the open-country owl *Asio flammeus*, and short hovering bouts do also occur occasionally among forest owls. Since hovering flight is the most energy-demanding type



Figure 4. - Like most forest owls, *Aegolius funereus* uses a "perch-and-pounce" hunting technique. This female is preparing for strike, showing intent attention towards the prey. Wild owl photographed in the field in SW Sweden on June 18, 1968. - Photo: R. Åke Norberg.



Figure 5. - Female *Aegolius funereus* striking a laboratory mouse released near the owl's nest in SW Sweden on June 14, 1968. The anteriormost primary wing feathers separate, exposing secondary leading edges to the air flow. But like the anteriormost primary feather, the exposed leading-edge portions of the next two feathers also have the comb-like, or serrated, structure that reduces aerodynamic noise. - From R. Å Norberg (1970, p. 59). Photo: R. Åke Norberg.

of locomotion, and since the ratio between the power needed to hover and the power available decreases with increasing mass of the bird, hovering can be expected to be less common among large than among small owls. Indeed, even the smallest owls probably exceed the critical mass below which continuous hovering can be sustained; hovering therefore probably incurs an oxygen debt in owls.

All owls use the eyes as well as the ears for prey detection and localization, but the relative importance of these senses varies among species. Specialization on one sense or the other opens up various possibilities for habitat selection and also dictates the range of hunting modes that can be used. But it also sets constraints to the types of habitat that can be efficiently exploited and to the ways prey can be efficiently searched for, involving the length of flight between perches, the height of perch, and the giving-up time before moving to a new perch (R. Å. Norberg 1970; Andersson 1981).

Visual search for prey requires a sparse forest and not too dense ground vegetation, which would conceal prey animals. Species hunting predominantly by eye usually select high vantage points from where they can search a reasonably large ground area for prey. *Surnia ulula* is a good representative of this category; it usually sits on top of trees, snags etc. and often detects prey animals at ranges far too long for acoustical detection. See also comments on *Surnia ulula* in the section: "2. Distribution of northern forest owls".

For an owl hunting in dense forest, trees and shrubs obscure much of the ground, so that a very small ground area is visible from a perch (R. Å. Norberg in preparation). This applies also when there is a dense ground cover. Under such circumstances the owl may do better by switching from using vision into relying predominantly on hearing for prey finding. But hunting by ear requires that the owl be close to the source of sound to increase its probabilities of detecting it, necessitating choice of very low perches. This worsens the prospects for visual detection, so in dense vegetation the hunting mode is dictated by what best governs auditory localization.

Aegolius funereus is a typical exponent of this hunting technique. It often hunts in very dense forest and even within thickets. And it selects very low perches, sometimes even sitting on stumps and tussocks. While following hunting owls during light summer nights in the Swedish Lapland, I recorded an average perch height of 1.7 m, an average flight length between perches of 17 m, and an average giving-up time at the perch of less than 2 min (R. Å. Norberg 1970).

Among the prey capture attempts that I witnessed, the following one illustrates how the owl's search tactic was influenced by its knowledge of where there was a prey. The vole population had crashed earlier

in spring, so prey was very scarce. I saw an owl strike at a prey, but missing it. It then flew back to the same branch from where it struck and remained there for 27 min - an unusually long time at a perch - often looking at the place where the prey had been. I made no further observations at this site, but had seen the owl on exactly the same perch once earlier the same night and once the night before. Several other perches were also used several times by the owl, in the same as well as in successive nights (R. Å. Norberg 1970).

I have also seen foraging *Aegolius funereus* and *Strix nebulosa* making long commuting flights between favourite hunting parts of their hunting territory.

From such observations, I think that owls foraging in a hunting territory know fairly well from prior experience - by sightings and auditory cues - where prey animals are. Their search behaviour in a familiar hunting territory therefore is probably guided by the conditional probabilities of prey detection, following upon knowledge of the approximate locations of prey. This must be borne in mind when testing theories of optimal search behaviour on owls, because most such theories depend on random prey distribution and assume no prior knowledge by the predator about prey location.

Most predators have a repertoire of search modes, each of which may be characterized by its search efficiency and the associated energy cost of locomotion. And the link is probably such that the most efficient search modes are also the most energy-consuming ones, whereas the ones cheapest in energy are also the least efficient. Otherwise there would not be a repertoire, but the predator would of course use the most efficient mode if it were also cheapest in energy costs for locomotion (R. Å. Norberg 1977).

An interesting question is how the choice between various search modes is affected by food availability. This has been explored by R. Å. Norberg (1977), using a mathematical model. The resulting prediction is that when prey is abundant, a predator should use high-cost and high-reward search methods, while at low prey densities low-cost and low-reward methods should instead be used. So, as prey density declines, a predator should shift to progressively less energy-consuming search modes even though they are associated with low search efficiencies.

With owls, this means that as prey density declines, owls should shift from frequent hovering, much flight, and short giving-up times at perches into search modes with less flying and longer giving-up times at perches, i. e. to less energy consuming locomotor patterns despite their lower efficiencies in prey-finding.

Similar results were obtained by Andersson (1981), using a different model based on probabilities

of prey encounter. It also treated optimal search heights.

Most owls are "searchers" in the sense that an overwhelmingly large proportion of their foraging time goes to search for prey, as opposed to pursuit and capture, which take far less time. Therefore owls cannot afford to refrain from catching a reasonably suitable prey, once detected, and so should be generalized in their diet. This is, admittedly, a vague statement, but may be taken as a generalization for most owls in a relative sense, as compared with other types of predators.

But even among owls themselves there are differences, some species definitely being more specialized than others. To mention but a few, the *Bubo* species and *Strix aluco* are generalized, with very wide diets, whereas *Strix nebulosa*, *Aegolius funereus* and *Asio otus* are more specialized, with narrower diets.

Very few tests of optimal foraging theory have been done with owls.

10. EYES AND VISION

Owls have very large eyes, surrounded by a sclerotic eye ring. It is formed by several small bony plates, forming a tube that widens backwards toward the retina. Because of this tubular eye ring the eyes have an extremely limited movability, amounting to about 1° only (Steinbach and Money 1973); for all practical purposes they may be regarded as immovable. Instead the owl turns its head for any change in direction of view.

The eyes are more forwardly directed in owls than in other birds. The left and right eyes therefore have largely overlapping visual fields, the binocular field width being 48° in *Strix aluco* (Martin 1986, p. 270). This is a prerequisite for instantaneous stereoscopic vision (as opposed to comparisons of successive views from different positions). But in owls, as in all other birds, the optic nerve from each eye crosses completely over to the diagonally opposite side of the brain (Hirschberger 1967).

In humans there is only a partial crossing over of the optic nerves, some of the optic nerve fibers going to the brain on the same side as the eye. Neural information from both eyes therefore reaches the same brain center, which permits the brain to compare the slightly different images of the same object, as seen from the slightly different angles of the two eyes. This makes depth perception possible.

But despite the complete crossing over of the optic nerves in owls, stereoscopic vision has been achieved via a different neural route than in man; it has recently been discovered that in owls there is instead a partial crossing over of nerves between optic brain centres, half of the fibers to the "visual Wulst" carrying information from one eye, the other half relaying information from the other eye (Karten et al. 1973; Pettigrew 1979).

Turning now to night vision, northern owls are not subjected to darker nights than are tropical owls. A snow cover drastically increases the light levels by night. And with overcast skies, light is reflected repeatedly between the snow and the cloud base, resulting in fairly light winter nights at high latitudes. When there is no snow, moonless nights with cloud in autumn are no darker at high latitudes than in the tropics. So the selection pressure for good vision at low light levels should be about the same regardless of latitude.

But forest owls experience much lower night-time luminance levels than do open-country owls. So it is among the most nocturnal owls, most restricted to foraging under a closed tree canopy, that evolution should have resulted in the best dark vision among owls.

The early realization 120 years ago that the many rod photoreceptors in the retina of owls are linked to the high sensitivity of the owl eye was part of the original evidence of the duplicity theory of vision, based on rod and cone photoreceptors (Schultze 1867; Martin 1986, p. 267). It has later been shown that at least some owls possess colour vision (Martin 1974).

As to vision in poor light, there are great differences between owl species. In *Strix aluco*, a strictly nocturnal owl, both absolute visual sensitivity and maximum spatial resolution at low light levels are close to the theoretical limit dictated principally by the quantal nature of light and the physiological limitations on the structure of vertebrate eyes (Martin 1986). But early claims that owl eyes are between 10 and 100 times more sensitive than the human eye to light in the human visual spectrum have been proved wrong. The same applies to the old suggestion that owl eyes might detect infra-red radiation (Martin 1986).

Recent analyses have shown that *Strix aluco* has an absolute visual sensitivity about 2.5 that of man, a more modest value. And what is more, this difference is within the normal five-fold range of absolute visual sensitivity in the human population. So there could be individual human subjects with better visual sensitivity than individual *S. aluco*. But the absolute visual sensitivity is 100 times higher in *S. aluco* than in the pigeon, *Columba livia* (Martin 1977; 1986, p. 268).

The difference in absolute visual sensitivity of the human and owl eyes can be accounted for by differences in the light-gathering power of the eyes. The minimum *f*-number (at the largest pupil diameter) is 1.3 in *S. aluco* and 2.1 in man, corresponding to a retinal illumination 2.6 times brighter in the owl than in man (Martin 1977). The value 2.6 comes from the ratio of the inverted *f*-numbers squared; $(1/1.3)^2/(1/2.1)^2$.

The *f*-number is the ratio between the focal length (approximately the distance from the front of the eye to the eye's focal plane) and the largest

entrance aperture (pupil) diameter. A camera lens with an f -number of 1.3 is regarded to be extremely bright (or fast, in photographic terms).

There is one more myth about owls to be removed, namely their supposedly poor vision in bright daylight. Owls see perfectly well at high, day-time, light levels (Martin 1986, p. 270), and northern owls, more than others, depend on good vision in bright light. Even some of the most nocturnal among all owls, such as *Strix uralensis* and *Aegolius funereus*, occur beyond the arctic circle where hunting must be done in full daylight throughout summer.

11. THE FUNCTION OF EAR ASYMMETRY IN OWLS - "ONE OF THOSE ENIGMAS IN ZOÖLOGY NOT TO BE SOLVED THROUGH THE RESEARCHES OF MAN"

11.1. History

As far as I know, the first time that the ear asymmetry in owls was mentioned in the literature is Street's note in 1870, in which he very briefly described the skull of an owl which he thought was of *Nyctale acadica* (now *Aegolius acadicus*). He presented no illustration of it. After his brief description, Streets (1870, p. 73) made the following cautious remark: "If there had been but a single specimen of this cranium I would have been led to regard this instance of symmetry as abnormal; but as the same peculiarity of structure is presented by two (these being the only representatives of the species in the collection), it would rather suggest itself as a normal condition, although instances of coincidence of abnormality exist..." It is understandable that the remarkable asymmetry of the skull of *Aegolius* caused considerable confusion (figs 6 and 7).

The next mention of ear asymmetry in owls is Collett's paper from 1871 which contains the first published illustration of asymmetrical ears in owls; the asymmetrical skull of *Aegolius funereus*. A very similar illustration appeared in the Norwegian version of this paper (Collett, 1872) and is reproduced as my figure 6. Collett made his observation independently of Street (1870), to whom he referred in a note added later. At the time Collett submitted his 1871 paper, the journal containing Streets 1870 article had probably not reached Europe according to an editorial note, "in justice to Herr Collett".

Collett put high confidence in his observations and expressed no hesitation in regarding this asymmetry, and those in other European owls (Collett 1881), as typical for the respective species. Collett made many original observations on ear asymmetry that have been overlooked in later studies. His two papers on owl ears, originally in Norwegian, are available also in English - for those

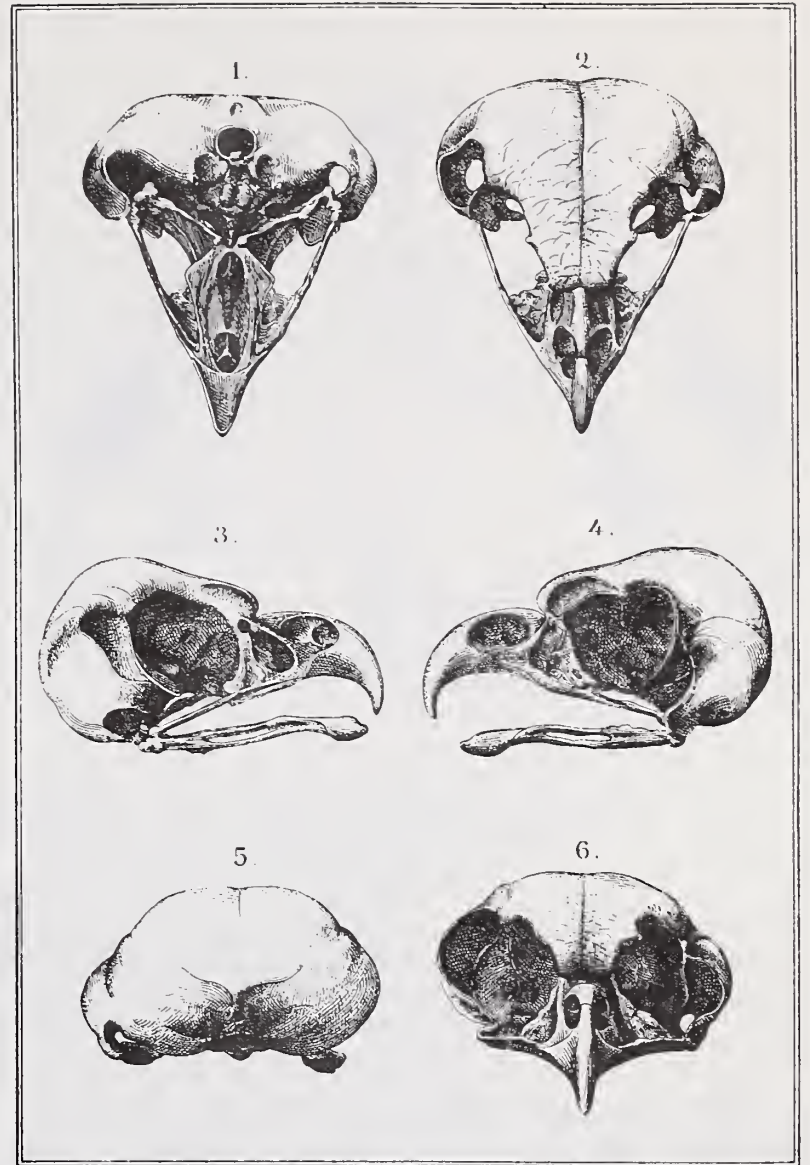
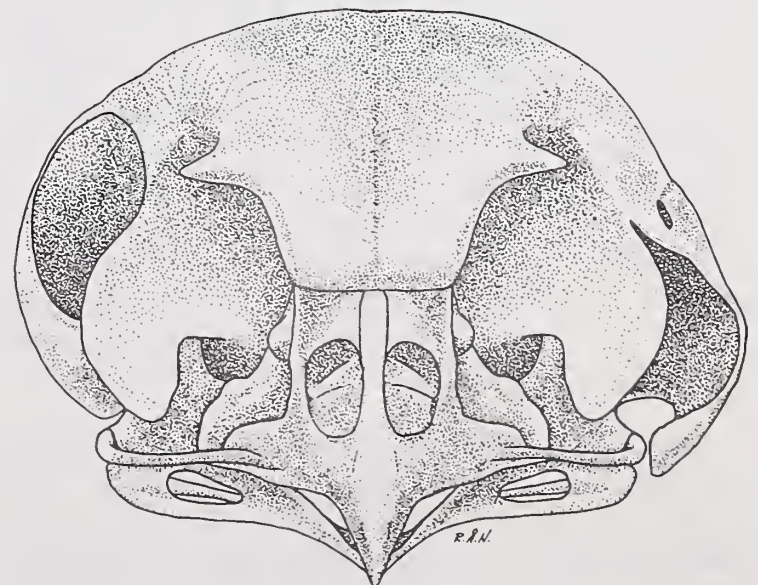
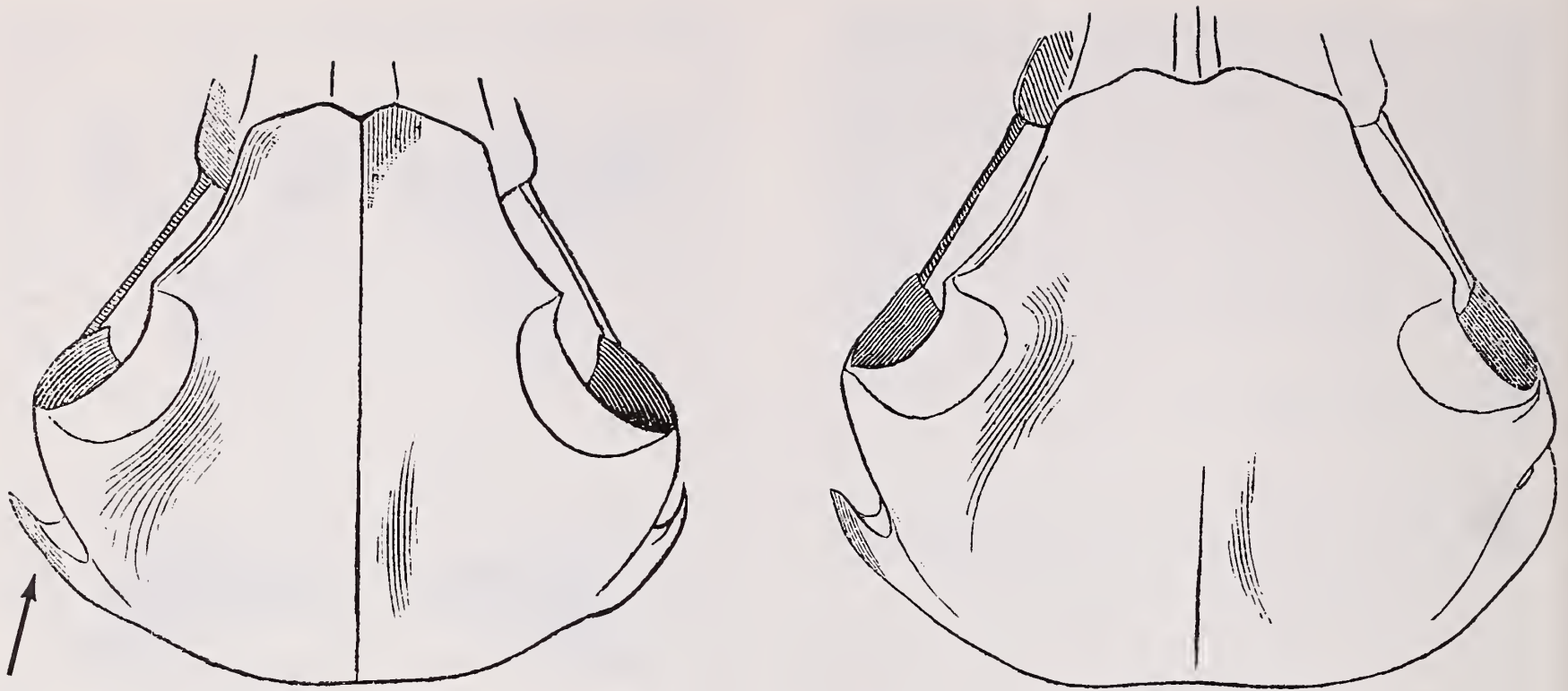

Figure 6. - The skull of *Aegolius funereus*. This illustration from Collett (1872) and a very similar one in Collett (1871) are the first published illustrations of ear asymmetry in owls.

Figure 7. - Frontal view of the skull of *Aegolius funereus*. - From R. Å. Norberg (1978, plate 8).





Figures 8 and 9. - Dorsal views of the skulls of *Strix uralensis* (8) and *Strix nebulosa* (9) showing the bilateral asymmetry of the squamoso-occipital wings, which are located lateral to the ear openings in the skull (indicated by the arrow). - Reproduced without change from woodcuts in Collett (1881, pp. 29 and 33). - The woodcut illustration technique is something to reflect upon when making today's computer-generated illustrations! This one is from a strictly scientific publication by Collett.

preferring that (Collett 1871 is an English version of his 1872 paper, and Shufeldt, assisted by his Norwegian wife, translated Collett 1882; Shufeldt 1901a, p. 120).

Collett (1881) described ear asymmetry in several European owls, and two of his 1881 illustrations appear as my figures 8 and 9. Figure 10 gives an overview of the occurrence of ear asymmetry among owls (from R. Å. Norberg 1977). It is discussed further in the section: "12. Evolution of ear asymmetry".

The bilateral ear asymmetry in owls attracted early attention and arouse curiosity about its function. Referring to the skull asymmetry in *Aegolius funereus*, Shufeldt (1901b, p. 715) wrote: "How such a condition as this asymmetry came to be evolved will probably remain one of those enigmas in zoölogy not to be solved through the researches of man. It is difficult for me to see what especial advantage it can bestow upon the bird, or how it would better fit it for the struggle for its existence."

11.2. Theories

11.2.1. Stresemann (1934)

Stresemann (1934, ppp. 133-134) seems to have been the first to associate the function of ear asymmetry in owls with directional hearing. With special reference to the asymmetry of the skull in *Aegolius*, Stresemann wrote (my translation from

German): "it would seem [dürfte] to be of importance for the localization of a sound source. During intent listening, owls usually move the head about the sagittal axis, i. e. turning one ear opening downwards, the other one upwards".

This was all that he offered in terms of explanation, but it was important, being the first time an association was made with sound localization. And the inference obviously followed naturally from Stresemann's observation of head tiltings in owls during sound localization, whereby one ear opening temporarily becomes located above the other (fig. 15) (to be discussed further below).

11.2.2. Pumphrey (1948)

The next big step towards an understanding of the ear asymmetry in owls came in 1948. From theoretical considerations, Pumphrey (1948, p. 324) formulated a theory for the horizontal and vertical localization of a sound source, using two ears. The conditions were supposed to be fulfilled by the asymmetrical ears of owls and were as follows:

"(1) The sound must be complex and the ears competent to resolve it into at least three bands of frequency in such a way that independent comparison of the signals arriving at the two ears is possible in each band.

(2) The two ears must have a direction of

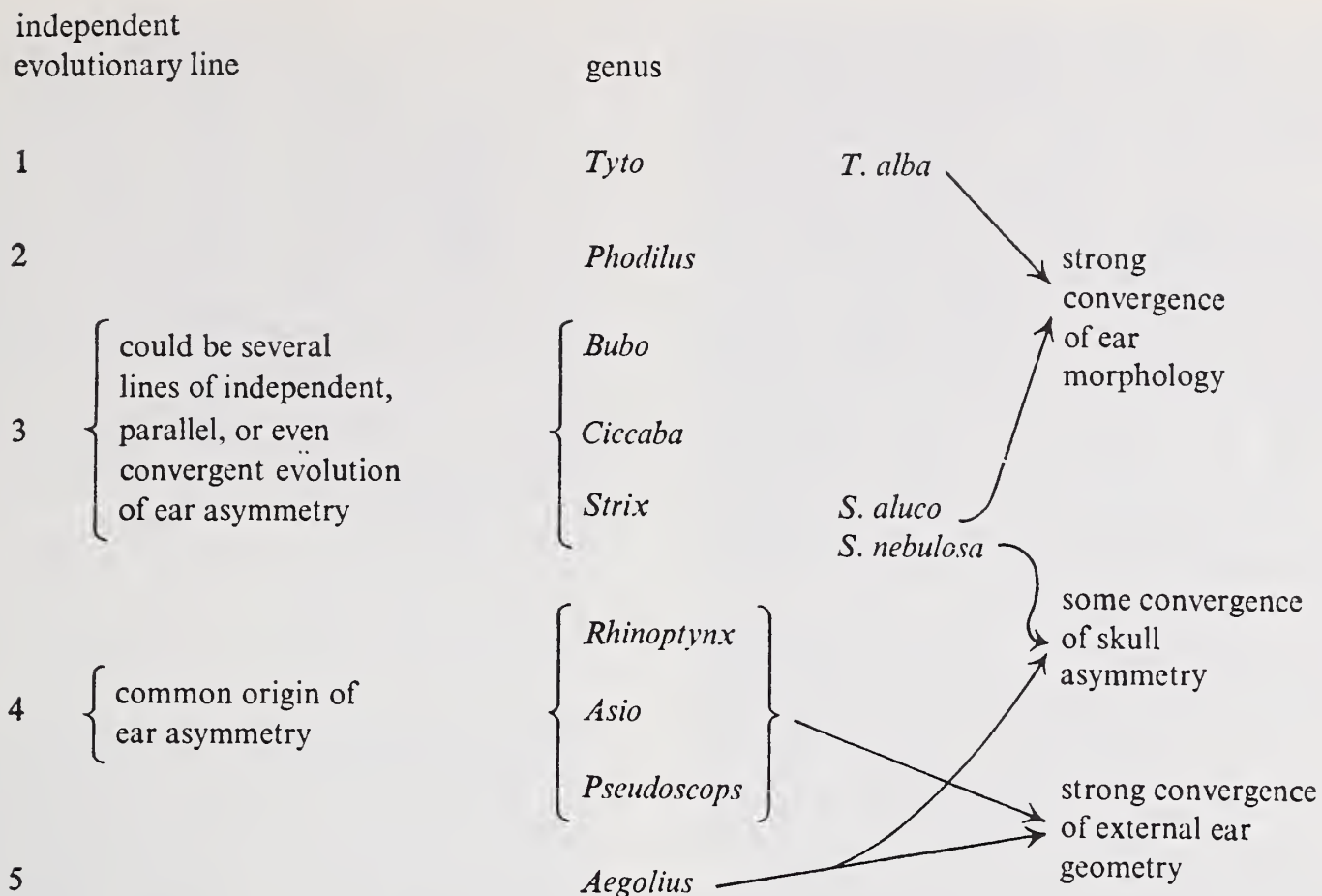

Figure 10. - Scheme summarizing the evolutionary history of ear asymmetry among owls. At least five cases of independent origin of ear asymmetry can be identified (left column). The convergence indicated for *Tyto alba* and *Strix aluco* could be extended to include more species of the genera *Tyto* and *Strix*, the ones listed being the most obvious and best known. But several *Strix* species lack any trend towards convergence in ear structure with *Tyto alba*. - From R. Å. Norberg (1977, p.402).

maximum sensitivity which is different for each band and is different for the left and right ear for at least two of these bands."

In discussing the ear asymmetry in *Asio*, Pumphrey (1948, p. 324) postulated a vertical asymmetry of the ears' directional sensitivity pattern: "...for wave lengths comparable with the slit lengths the direction of maximum sensitivity will be directed above the horizontal plane for the right ear and below it on the left." These predicted asymmetries of the directional sensitivity patterns at high frequencies were first verified by R. Å. Norberg in 1968. Payne (1971, p. 566) cited a personal communication by Pumphrey, further explaining Pumphrey's theory.

Pumphrey's (1948) theory is extremely insightful. But it is very general, and as regards the asymmetrical ears of owls it is somewhat vague. The theory given by R. Å. Norberg (1968; see below) is more precise and simpler; but it satisfies the two minimum conditions given by Pumphrey and so can be seen as a special case of Pumphrey's fairly general formulation.

11.2.3. Payne (1962)

Based upon recordings of sound intensities at

the eardrums of the barn owl, *Tyto alba*, Payne (1962, pp. 157, 159) concluded:

"Throughout the spectrum of the frequencies audible to the Barn Owl, one area surrounding the line of sight will always receive sounds at maximum intensity." "... all features [of the directional sensitivity diagrams] in the right ear occur about 10 to 15 degrees higher than their mirror image complements for the left ear. This is undoubtedly linked with the asymmetry of the ears. ... My theory, then, puts only one demand on the owl, namely, that it orient the head in such a way as to hear all frequencies, audible to it in a complex sound, at maximum intensity in both ears. When it has achieved such an orientation, it will automatically be facing the source of the sound..."

This theory has not been supported by later work. But in 1971 Payne suggested a modified version, which is more similar to that of R. Å. Norberg (1968; see below).

11.2.4. Norberg (1968); "The Pumphrey-Norberg theory"

As late as in 1968, 67 years after Shufeldt's remarks in 1901 (Shufeldt 1901b, p. 715; see above:

"11.1. History"), the problem still remained of giving a functional interpretation of the ear asymmetry in owls, as highlighted by the following statement by Schwartzkopff (1968, p. 45): "The difficulties of combining morphological and ecological data with physiological findings are illustrated most clearly by the almost historical problem of explaining the asymmetry of the external ear in some owls".

In 1968 I presented a complete, but simple, theory on the principles of the function of the morphological asymmetry of owl ears (R. Å. Norberg 1968). It was based on data from acoustical measurements on a model head, using a skull of *Aegolius funereus*, with soft plastic material replacing soft anatomy parts, covered by a natural skin with feathers, and with 6.3 mm diameter microphones replacing the eardrums.

The theory states that an owl with asymmetrical external ears can localize the direction of a sound source binaurally both in the horizontal plane (in azimuth) and in the vertical plane (in elevation), simultaneously, and with the same accuracy, without an additional judgement after turning the head about its longitudinal axis. A condition is that the sound contains low as well as high frequency components. And rustling sounds made by prey moving in snow as well as in vegetation, fresh or dry, do cover a wide frequency spectrum, therefore fully satisfying this requirement (R. Å. Norberg 1968, p. 201).

The principles of directional localization with asymmetrical ears are as follows (from R. Å. Norberg 1968) (see figs 11-14):

Horizontal, or azimuth, determination :

1. By comparison of the times of arrival of sound at the two eardrums, i.e. by measuring interaural time differences by binaural comparison.

2. By comparison of the intensities in the two ears of low-frequency components of the sound, i.e. by measuring interaural intensity differences by binaural comparison.

For sounds of low frequencies, with wave-lengths longer than the dimensions of the head, the morphological asymmetry does not affect the directional sensitivity pattern of the ears. For such low frequencies, the ears therefore function like symmetrical ears, providing time and intensity cues for horizontal localization in the usual way, as described above under point 1 and 2 (figs 11, 12, and 14).

Vertical, or elevation, determination :

3. By comparison of the intensities in the two ears of high-frequency components of the sound, i.e. by measuring interaural intensity differences by binaural comparison.

This is identical to point 2 above, except that it is for high frequency sound components, whose wave-lengths are about equal to, or shorter than, the dimensions of the ear opening and head. For such

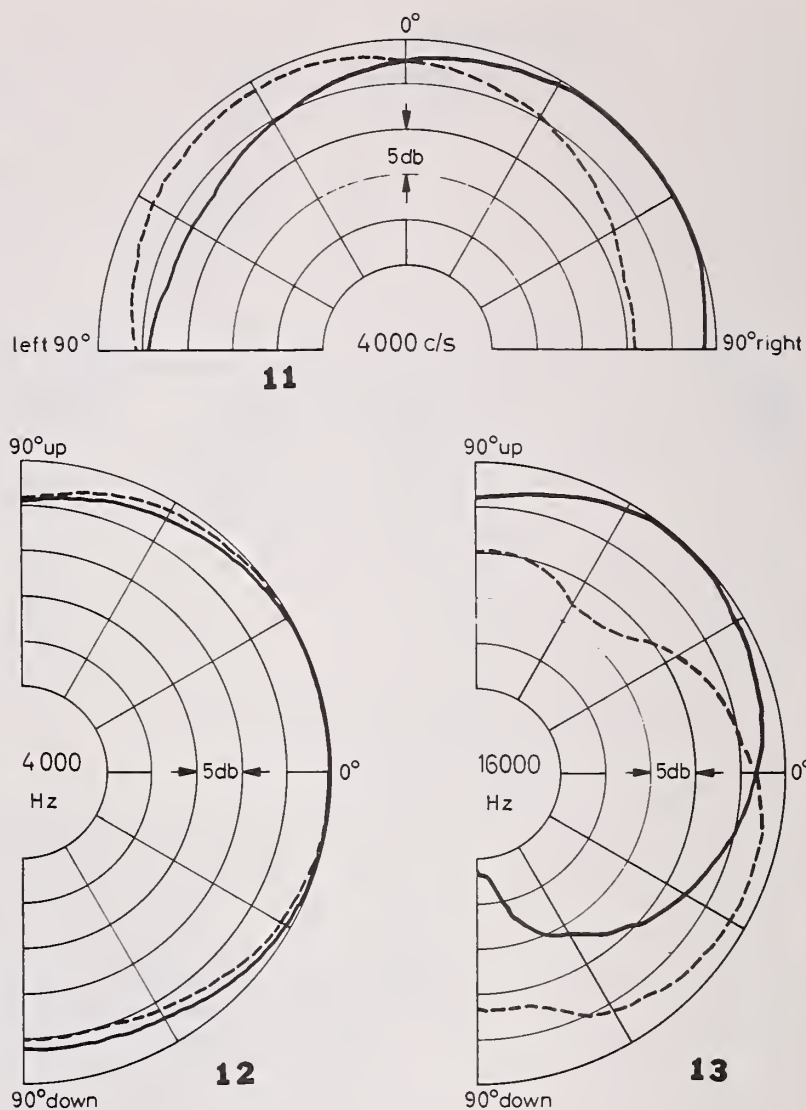

Figures 11, 12, and 13. - Relative sound pressure levels at the left (-----) and right (-----) eardrums in *Aegolius funereus*, measured on a model head built on a skull, covered with skin and feathers, and with soft plastic material replacing soft anatomy parts. The upper diagram is for directions of incidence of sound in front of the owl and in the horizontal plane of the head. Comparison of intensities in the left and right ear enables the owl to localize a sound source in the horizontal plane, using low frequency components of the sound. - The diagram at lower left is for directions of incidence of sound in front of the owl but in the vertical plane of the head. The structural asymmetry of the ears has no effect on their directional sensitivity at low frequencies. Therefore, the ears are functionally symmetrical at low frequencies, and provide no cues to vertical localization. - The diagram at lower right is also for directions of incidence in the vertical plane of the head. But at high frequencies the structural asymmetry of the ears strongly influences their directional sensitivity. Comparison of intensities in the left and right ear enables the owl to localize a sound source in the vertical plane, using high frequency components of the sound. This is an important function of ear asymmetry. - From R. Å. Norberg (1968, pp. 193, 196).

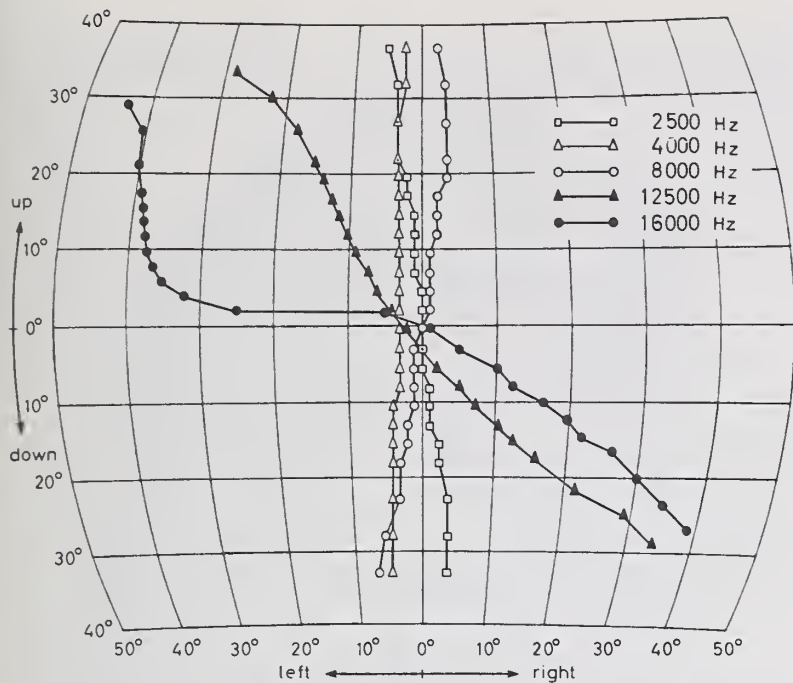

Figure 14. - Projection of the space in front of the owl (*Aegolius funereus*). The curves show from which directions of incidence a sound is equally loud in both ears for various frequencies. These are important reference directions; the horizontal direction of a sound source can be judged with reference to the vertical, equal-sensitivity, curves for low frequencies, and the vertical direction can be judged with reference to the oblique, equal-sensitivity, curves for high frequencies. - From R. Å. Norberg (1968, p. 197). Later measurements on intact heads, using a probe tube microphone, showed vertical asymmetries also at somewhat lower frequencies, at 8000 Hz and 10 000 Hz, and to a lesser extent at 6300 Hz (R. Å. Norberg 1978, pp. 405-406).

sound, the structural asymmetry of the ears does affect the ears' directional sensitivity so that the region of maximum sensitivity is directed obliquely downwards for one ear, obliquely upwards for the other. This provides excellent cues for vertical localization via binaural intensity comparisons, just as for horizontal localization with lower frequencies, under point 2 (figs 13 and 14). The version of this theory given by R. Å. Norberg in 1978 (pp. 407-408) is identical except for the delimitation of frequency domains for azimuth and elevation determinations in *Aegolius funereus* (see legend to fig.14).

To summarize: An owl with asymmetrical ears can determine the direction of a sound source simultaneously in the horizontal and vertical planes by using (1) binaural *time* comparisons and the whole frequency spectrum for *horizontal* localization, (2) binaural *intensity* comparisons and *low* frequency components for *horizontal* localization, and (3) binaural *intensity* comparisons and *high* frequency components for *vertical* localization (figs 11-14).

This theory satisfies the two minimum

conditions given by Pumphrey (1948) and so can be seen as a special case of Pumphrey's fairly general, but insightful, formulation. I therefore follow Knudsen (1980, p. 309) and term it "*The Pumphrey-Norberg theory*".

This theory has been fully supported by behavioural and neurophysiological work made on the barn owl, *Tyto alba*, by Knudsen (1981); Knudsen, Blasdel, and Konishi (1979); and Knudsen and Konishi (1979). They have shown convincingly that barn owls do localize sound as predicted by "*The Pumphrey-Norberg theory*". But the claim by Knudsen (1980) of having devised a new theory of sound localization by the addition to my theory of an interaural time factor is absolutely wrong. It was all contained in R. Å. Norberg (1968, pp. 198, 199; and again in 1978, p. 407). For instance, in discussing horizontal localization with the aid of interaural time differences, I concluded: "The ear apertures in *Aegolius funereus* thus are set so far apart that the interaural time difference may well be of considerable importance in the owl's directional hearing." (R. Å. Norberg 1968, p. 198).

Knudsen and Konishi have made exciting neurophysiological work on owl hearing, and among other things described a neural map of auditory space in *Tyto alba* (Knudsen and Konishi, 1978). Even though different directions of incidence of sound become codified as binaural differences in time and intensity, the neural representation of the various directions is in the form of a morphological map of neurons in the brain, reflecting the auditory space outside.

11.3. Head and ear size

The longer the distance between the two ears, the larger the difference in time of arrival of a sound at the two eardrums, and the better the accuracy of localization with time cues, given a certain angle of incidence (R. Å. Norberg 1968, p. 198). And the larger the head and ears are, the more pronounced the directionality of the ears become (i.e. the larger the deviation from omnidirectionality, or equal sensitivity in all directions), and the better the accuracy of localization with intensity cues at low frequencies.

Similarly, when the ears are asymmetrical, larger head and ears means that the asymmetry affects the ears' directional sensitivity pattern already at lower frequencies than with smaller head and ears (R. Å. Norberg 1978, p. 405). And since sound of low frequencies carry longer than those of high, a big head and large facial ruffs and discs are advantageous for directional hearing. This explains why the head is so large, particularly among owls relying much on hearing for prey localization.

11.4. Sound localization with symmetrical ears

I should maybe add that it is not against the rules for an owl with perfectly symmetrical ears to localize, by ear, a concealed prey making rustling sounds, and to catch it with high precision. But in order to achieve the same accuracy in vertical localization as do owls with asymmetrical ears, it would need to make two directional judgements with an intervening tilting of the head through 90° in between, or two tiltings through 45°, in opposite directions (Figure 15). The latter seems to be the most common mode in, for instance, *Surnia ulula*.

So, the main advantage with asymmetrical ears is that the horizontal and vertical direction of a sound source can be determined simultaneously, with the same accuracy in both planes, and without head tilting. This saves time. But more importantly, it seems to be indispensable for localizing and catching hidden prey that moves; with asymmetrical ears the precise location of a moving prey can be continuously monitored. But with symmetrical ears, horizontal and vertical directions have to be determined one at a time, one after the other, with an intervening tilting of the head in between.

11.5. Head tilting in young owls with asymmetrical ears

In view of what has been said above about owls with asymmetrical ears having no need of tilting the head during sound localization, it might seem disturbing - to put it mildly - that young owls do tilt their head intensively during sound localization. And what is more, this is done particularly by species with strongly asymmetrical ears, such as *Asio otus* and *Aegolius funereus* (fig. 15).

But considering the kind of conflicting information that they receive from the two ears, it is obvious that this is part of a learning process that is necessary before they can take full advantage of their ear asymmetry (R. Å. Norberg 1973, pp. 99, 101). Look at figure 14 and consider a sound source that is located straight ahead but somewhat upwards (in the head's median, sagittal, plane but above its horizontal plane). Then the sound reaches both ears simultaneously, and low frequency components are equally loud in both ears, which indicates that the sound source is in the median plane of the head. But high frequency components are louder in the right ear, and this the owl must probably learn to interpret as a sound coming from above, not from the right. Presented with this acoustical input, we would perceive a phantom source, distributed in space, with low frequencies straight ahead, but with high frequencies to the right. The head tiltings in young owls of some species with asymmetrical ears strongly suggest that the rule for how to interpret this



Figure 15. - Young *Aegolius funereus* tilting its head through about 90°. Extensive head tiltings occur in young owls among species with asymmetrical ears - exactly the ones that would seem not to need it. This is obviously for training to interpret correctly the conflicting auditory information received from the two asymmetrical ears, as explained in the text. Once this information can be correctly used, species with asymmetrical ears can judge both the horizontal and vertical direction of a sound source at the same time, without tilting the head (provided the sound contains high as well as low frequency components). Captive owl, July 1964. - From R. Å. Norberg (1973, p. 99). Photo: R. Å. Norberg.

information correctly is not innate in these species, but has to be learnt.

Head rotation is a means of resolving this ambiguity; when the axis of rotation of the head passes through the true location of the sound source, rotation of the head does not cause any change of the binaural pattern of the sound perceived. With all other orientations it does.

But when these head rotations occur in owls - young or adult - with symmetrical ears, they are for

vertical localization, rather than for resolution of information that is hard to interpret without experience.

12. EVOLUTION OF EAR ASYMMETRY

12.1. The origin of ear asymmetry

Owls that rely much on hearing to locate prey may do so either because they select a habitat where vision is obscured by dense vegetation, or because prey is concealed among dense ground vegetation or under snow. To increase the probabilities of detecting prey by ear, the owls need to be close to the sound source. This is why those species, which hunt predominantly by ear, usually sit or fly low over the ground when searching for prey (R. Å. Norberg 1970).

When such an owl has detected a rustling sound, and starts localizing the source, the direction of the sound source usually forms a shallow angle with the ground because of the low position of the owl. Therefore, with a given angle of localization error, the same in elevation and azimuth, the "range

miss" becomes larger than the "lateral miss", i. e. the distance that the owl misses the target by striking too close or too far away with respect to the target is bigger than the lateral distance that the owl strikes to the side of the target (fig. 16) (R. Å. Norberg 1977). This is a crucial factor that calls for good vertical localization ability of all owls which rely on hearing for prey localization. It is also an important reason for the evolutionary origin of ear asymmetry among owls.

12.2. Convergent evolution of ear asymmetry

Selection pressure for improved ability of vertical localization of sound obviously lies behind the evolution of all types of bilateral ear asymmetry among owls. Various evolutionary lines have produced different structural solutions which probably represent various degrees of success (R. Å. Norberg 1977).

After careful examination and comparison of the morphology of owl ears, R. Å. Norberg (1977) concluded that ear asymmetry has evolved

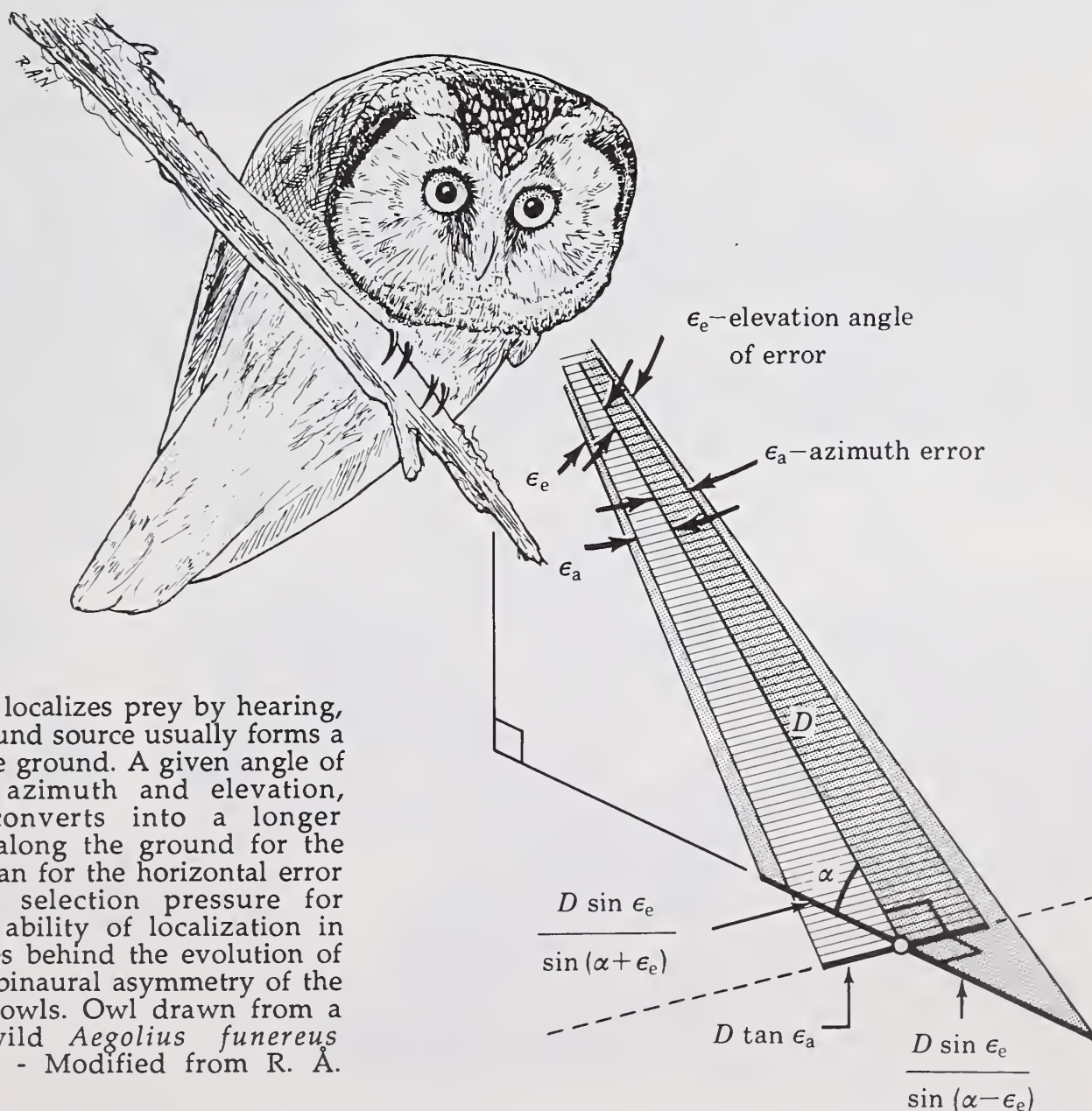

Figure 16. - When an owl localizes prey by hearing, the direction of the sound source usually forms a shallow angle with the ground. A given angle of error, the same in azimuth and elevation, therefore usually converts into a longer target-miss distance along the ground for the vertical error angle than for the horizontal error angle. The ensuing selection pressure for improvement of the ability of localization in elevation probably lies behind the evolution of all types of (vertical) binaural asymmetry of the external ears among owls. Owl drawn from a photograph of a wild *Aegolius funereus* preparing for strike. - Modified from R. Å. Norberg (1977, p. 401).

independently in at least five evolutionary lines among owls. The generic representation appears in figure 10.

The presence of a snow cover during a large part of the year at high latitudes is probably one reason why such a large proportion of the northern forest owls have asymmetrical ears (41% of the species; see above: "2. Distribution of northern forest owls; 2.2. Conclusion"). This relationship probably came about in two ways; (1) the evolution of ear asymmetry probably took place at high latitudes within some of the phyletic lines that ever produced it, governed by strong selection for improved abilities of auditory localization of prey under a snow cover; and (2) species that have evolved ear asymmetry elsewhere can more easily invade northern latitudes than can species with symmetrical ears.

The analysis of ear structure among owls also led to a firm rejection of the former systematic subdivision of the Family Strigidae into the subfamilies Buboninae and Striginae. The subfamily Striginae was erected by Peters (1940) to accommodate owls with big heads and large ears, thought to represent one monophyletic group. But these owls have a mixed phylogenetic origin, as revealed among other things by the morphology of their ears (R. Å. Norberg 1977).

13. OWLS AND PREY CYCLES

In the ecological context, most owls are closely associated with small mammals, in particular with small rodents. Predator-prey interactions play an important role in the regulation of population densities of both owls and small mammals, even though the mechanisms are intricate.

The dramatic cyclic population fluctuations among mice, voles, and lemmings at high latitudes are one of the most fascinating phenomena in ecology (figs 17-20). The famous population cycles of small rodents are a classic problem in population ecology. Small rodent predators, including owls, track the fluctuations of their prey. But the rodent cycles are not simply driven by predators, even though predators definitely interact with prey numbers. Various explanations of the rodent cycles and the mass-irruptions have been much debated through times.

Let us focus on the Norway lemming, *Lemmus lemmus*, which is a well-known, but extreme, example of a cyclically fluctuating vole. It has a very restricted distribution in alpine regions in Norway, Sweden, Finland, and on the Kola peninsula, where it occurs in the alpine birch forest and the lower parts of the alpine heath. Its cyclic mass occurrence,



Figure 17. - The first known illustration of lemmings. Woodcut from 1555 showing Norway lemmings, *Lemmus lemmus*, falling with the rain, reflecting the then prevailing view of the origin of their mass-occurrence in "lemming years". The group of lemmings at lower left probably symbolizes an irruptive movement, and predation on lemmings is shown to the right. - From Olaus Magnus (1555; reprinted 1976, Vol. 4, p. 60).



Figure 18. - Detail of woodcut from 1555 showing an eagle owl, *Bubo bubo*, preying on hares and another owl taking a rodent. - From Olaus Magnus (1555; reprinted 1976, Vol. 4, p. 156).



Figure 19. - An artist's representation of an irruption of Norway lemmings, *Lemmus lemmus* at the turn of the last century. - Based on Brehm; From Jägerskiöld, Lönnberg, and Adlerz (1903, p. 9).

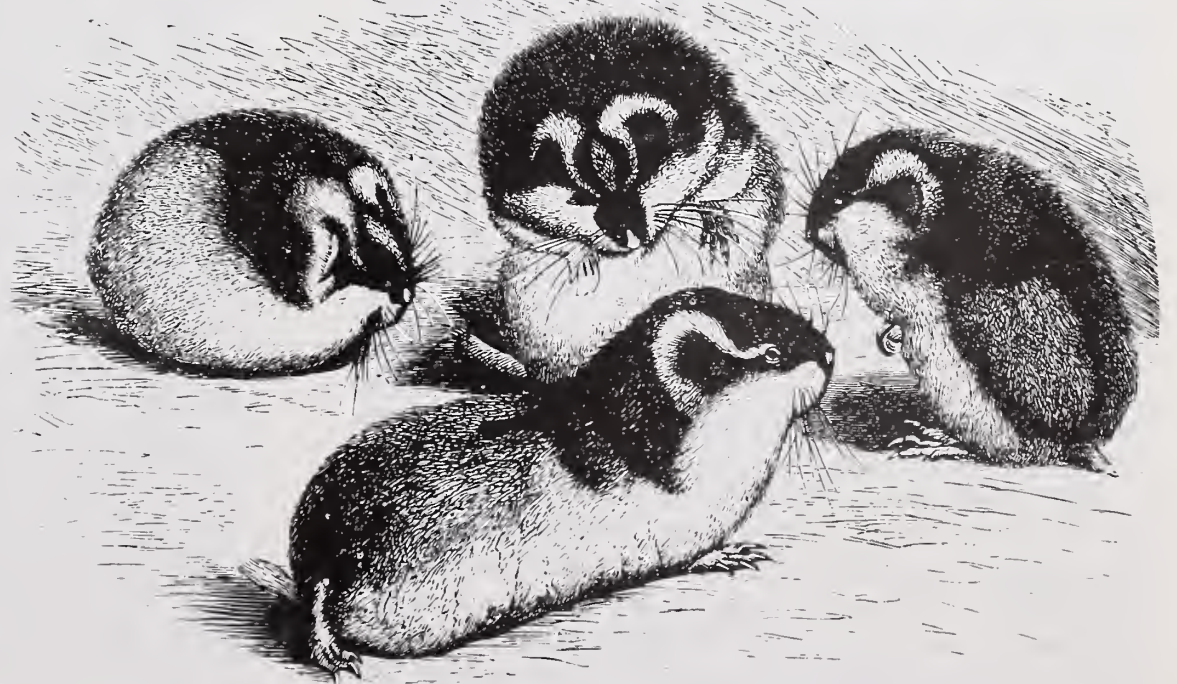

Figure 20. - *Lemmus lemmus* in close view. - From Brehm (1922, Vol. 11, p. 259).

sometimes followed by large-scale irruptions, which take it far beyond its ordinary distribution range, have caused much speculation and many misconceptions.

In "History of the Scandinavian People" from 1555, Olaus Magnus made an early attempt (430 years ago) at explaining where lemmings came from when they suddenly, and enigmatically, appeared in enormous numbers in areas where they did not normally occur (my translation from Swedish): "During rainstorms and sudden showers it sometimes happens that small quadrupeds, called 'lemmar' [lemmings], the size of voles and with mottled fur, fall down from the sky. It is not known from where they come, whether they originate from remote islands and have been carried here by winds, or if they have simply [sic!] been produced by fertile clouds and thence arrived to the ground. It is true, however, that soon after they have fallen to the ground one can find still undigested herbs in their bowels." Olaus Magnus also presented the earliest known illustration of a lemming, in the form of a woodcut (fig. 17). It shows lemmings falling with the rain, but also a group of lemmings, probably symbolizing their mass-movements, as well as carnivores preying upon them (see also figure 18).

A much more recent misconception about the exodus of lemmings in peak population years is the view that their movement away from an overcrowded area, leading to most of the irruptive animals dying from starvation, predation, or by drowning, is a bizarre altruistic mass-suicide, "for the survival of the species", which leaves the few remaining animals to survive when competition for food has thus been relaxed. Such group selection, "for the good of the species", arguments must be replaced by explanations based on individual selection (Williams 1966; Dawkins 1976).

The small rodent fluctuations are periodic with an average of about four years between population peak years, but shorter and longer intervals do sometimes occur. Similar population cycles occur also in the snow-shoe hare, *Lepus americanus*, and among its main predators. But this famous wildlife population cycle is about 10 years long, a result of the lower reproduction potential of the hares as compared with voles and lemmings.

There is a very clear geographic trend for cyclic population fluctuations among small mammals; the farther to the north they exist the more common the fluctuations become and the larger their amplitudes (but the periodicity is still about four years) (Hansson and Henttonen 1985).

The reasons for the cyclicity and the migratory outbreaks, and the mechanisms involved, are still not fully understood. There obviously are interactions at four levels; between the soil, the vegetation, the rodents, and the predators. And time delays, cyclic phenotypic and genotypic changes of the

plants and rodents, as well as behavioural changes in rodents, are also involved (Krebs et al. 1973). Parasites and diseases may also play a role.

A simplified view of the process is as follows. After a population minimum, when populations of plants, rodents, and predators have all crashed (or the plant quality as food has deteriorated), the vegetation starts to recover, followed by an increase in rodent number. Predators eventually increase in number also, but because of the necessary time delay, and their lower reproduction potential as compared with rodents, they cannot match the rodents' rate of increase and therefore cannot regulate rodent density until rodent numbers approach a ceiling, set by vegetation.

The growth of plants may eventually be retarded owing to depletion of nutrients in the soil. And an ultimate limit to plant density is set anyway by packing constraints (R. Å. Norberg, in press). Therefore, rodents eventually overexploit the vegetation, whereupon the rodent population crashes. The predators, having by now reached high population densities, may still survive for some time by switching partly to alternative prey. But they are destined eventually to decline heavily in number, by starvation and emigration.

When the population density of small mammals increases, their predators may respond in two ways; by switching to eating more rodents (functional response) and by increasing in density by reproduction or immigration (numerical response). Predators are likely to have the following five effects on small rodent cycles and on the population fluctuations of other prey animals.

(1) Predators retard the population increase of their small rodent prey, thus tending to lengthen the cycle.

(2) When small rodents are reaching high population densities, many predators that normally eat mainly other prey do switch over to eating rodents, which are easy prey, leaving their normal prey species to increase in numbers. Their population densities therefore tend to increase in synchrony with that of rodents, but with some time delay.

(3) Because predators switch over partly to other prey during the rodent decline phase, they survive for some time despite the rodent decline and so can continue to reduce the densities of the small rodent populations until they reach much lower levels than would have been attained without predators. This is possible because when rodent density has started to decline (primarily for other reasons than predation), the density of rodents becomes progressively lower in relation to predator density. This is in striking contrast to the increase phase, when the strong numerical dominance of rodents, together with their then high rate of increase, led to runaway population growth, inaccessible to predator control.

(4) After predators have switched partly to alternative prey, they cause a population decline among these prey also; it occurs somewhat after the time of the rodent population crash, but clearly synchronized with it. Predators should be more able now than at other times to exert population control over other prey, because the previously high densities of small rodents have enabled the predators to build up higher population densities than they could have done without the rodent outbreak.

(5) Predators are likely to emigrate to new areas during their peak and decline phases, and they therefore tend to synchronize population fluctuations of their prey (small rodents as well as others) over large areas, the population minimum of small rodents in the source area being the synchronization set point. But time delays, owing to the time elapsed before emigration starts and for predation to reduce prey densities in the target areas, lead to a phase displacement between areas.

When the predators involved are specialized on small rodents as food, and cannot survive for long on alternative prey, the predators have a destabilizing effect on their prey as just described, tending to increase the amplitude of the population fluctuations in rodents.

But when the predators are more generalized, being able to survive entirely on other prey than small rodents, they remain at fairly high densities even after small rodent populations have crashed. Such predators are therefore always present at high enough densities to be able to control the density of small rodents when they start to increase. Further south, other potential prey species than small rodents are usually commoner than at high latitudes. This favours generalized predators, and this is probably the main explanation why the population cycles of small rodents are much less there than at high latitudes (Erlinge et al. 1983; Hansson and Henttonen 1985).

To summarize, predators specialized on small rodents as food tend to destabilize the rodent cycles, whereas generalized predators tend to have a stabilizing effect, sometimes to the extent that cyclic fluctuations are suppressed altogether among small rodents. And specialized as well as generalized predators both tend to synchronize population fluctuations of small rodents and alternative prey, both locally and over larger areas. The time of the rodent population minimum is the synchronization set point, i. e. when the phase-lock is achieved. The larger mobility that predators have, the larger the area over which they may synchronize population fluctuations among their prey. So, owls and diurnal birds of prey have larger potential for effecting large-scale geographic synchronization of prey cycles than have carnivorous mammals with their lower mobility.

In 1941 Stig Wesslén, a Swedish wildlife

photographer and writer, vividly described how owls and raptors, occurring at extremely high densities, switched over to alternative prey after a population crash of *Lemmus lemmus* and other small rodents in early summer in Swedish Lapland; and different predator species even turned to eating each other under the prevailing, desperate, starvation conditions. This continued until the whole predator population was completely wiped out due to nest desertion, starvation, predation, and emigration. Wesslén (1941, pp. 145-159) clearly recognized that predators effected a synchronization of population fluctuations of small rodents and of alternative prey animals, such as hares, ptarmigans, grouse, ducks, shorebirds, and passerines.

Yngvar Hagen (1952, pp. 583-588) made similar observations of different predator species eating each other after a small rodent crash in Norway. He also provided data on the strict synchronization between population fluctuations of small rodents and game birds, *Lagopus*, and attributed this to predators, as outlined above (my points (2) and (4)). Later studies confirm a synchronization effect by predators across prey species (Hansson 1984; Henttonen 1985; Järvinen 1985).

To gain a thorough understanding of the interactions between populations of predators and prey, and the effects that predators have on the regulation of prey population density, studies should be conducted on the collective populations of all essential species of prey as well as of predators. Examples of such large-scale ecological studies on small rodents and their predators, including owls, are the classical work by Craighead and Craighead (1956) and a more recent study by Erlinge et al. (1983). Both show that predation has a regulatory effect on small rodent populations.

Northern owls are very flexible in the number of eggs they lay in a clutch; they can markedly increase or decrease clutch-size in immediate reaction to available food-supply (figs 21 and 22). In areas where the prey populations undergo marked fluctuations the owls do even refrain from breeding in bad years.

In areas where small rodents are strongly cyclic, the owls that are most specialized on small rodents tend to be nomadic - such as *Asio otus* and *Asio flammeus* - whereas species with a generalized diet show site tenacity - such as *Strix uralensis* and *Strix aluco* (Mysterud 1970; Lundberg 1979; Sonerud 1986). Still others may show a mixed strategy, females tending to be more nomadic than males, which seems to be the case in *Aegolius funereus* (Lundberg 1979; Wallin and Andersson 1981; Löfgren, Hörnfeltdt, and Carlsson 1986; Korpimäki, Lagerström, and Saurola 1987).

When there is low correlation from place to place in food fluctuations, nomadism is obviously advantageous for predators that are strictly specialized on cyclic prey (Andersson 1980). And



Figure 21. - Example of a supply of surplus prey in an owl nest in a year when prey is abundant. This is from a late nest of *Aegolius funereus* in SW Sweden (at Kelles) on May 20, 1973, when the first egg was just laid. There was no egg on May 19, so the prey represent "courtship feeding" prior to egg-laying. The 18 prey animals are (from top left to bottom right): 2 *Microtus agrestis*, 2 *Clethrionomys glareolus*, 1 bird nestling, 12 *Sorex araneus*, and 1 *Sorex minutus*. Their combined weight was 191 g. Of these 18 prey only one *Sorex araneus* remained in the nest on May 22. The female eventually laid 7 eggs, which is unusually many; 6 eggs hatched and 5 young fledged. - Photo: R. Åke Norberg.

when a rodent population crash has hit an area at high latitudes, migration southward should be advantageous for rodent predators even if rodent cycles were synchronized and in phase over large areas. This is because a rodent crash at high latitudes often results in extremely low rodent densities, probably much lower than further south where there is less cyclicity, or none at all.

Differences in yearly, winter, migration patterns between northern owls are affected by prey availability as determined by choice of hunting habitat, hunting mode, and visual and auditory prey localization abilities (Sonerud 1986).

The regular and violent population fluctuations among small mammals and their predators at high latitudes may allow higher evolutionary rates than would otherwise be possible. This is further explained at the end of the next section: "14. Adaptations among northern forest owls".

14. ADAPTATIONS AMONG NORTHERN FOREST OWLS

The most conspicuous adaptation among owls to the cold northern climate is the dense feathering, in



Figure 22. - Female *Aegolius funereus* in another nest in SW Sweden (at Flottatjärn) with 6 young on May 4, 1973. All 6 fledged. This was another large brood in a year with high food abundance. - Photo: R. Åke Norberg.

particular around the bill and on the legs and toes. For example, the northern fish owl *Ketupa blakistoni* differs from the other, more southern, fish owls in having feathered tarsi (Fogden 1973). And in the northern part of its range, the collared scops owl, *Otus bakkamoena*, has dense plumage on its tarsi and in Japan and China even the toes are well feathered (Hekstra 1973, p. 103).

Another plumage characteristic is the predominance of grey colour among northern owls, which may be a thermoregulatory adaptation (see above: "3. Colour morphism").

Ear asymmetry occurs in a much larger proportion of the species among northern owls than among tropical ones. A reason is that the occurrence of a snow cover during much of the year should select strongly for ear asymmetry, probably leading to its evolution at high latitudes, but also favouring invasion of species who evolved ear asymmetry elsewhere.

The rationale for this is as follows. A snow cover drastically damps the rustling sounds made by prey moving in tunnels in the snow or in the subnivean space. Owls attempting to detect such sounds therefore need to be close to the sound source, and so should select low perches or fly low

over the ground if searching for prey in flight. When sounds are detected from low heights, the directions of the sound sources form shallow angles with the ground. This tends to result in large localization errors in elevation, which in turn result in "range misses" - the owl striking too close or too far away with respect to the target. Vertical asymmetry of the external ears reduces this elevational error and the associated range miss. And this is the reason for the evolutionary origin of ear asymmetry among owls (see section: "12. Evolution of ear asymmetry").

Small mammals living beneath the snow are difficult to detect and localize. Plunge-holes in the snow, such as those shown in figure 25, are striking evidence (no pun intended) of the efficacy of the asymmetrical ears in owls. It should be noted, however, that some rodents, in particular *Microtus* species, frequently dig ventilation shafts from their subnivean space up to the snow surface. And as voles visit tunnel openings, owls may sometimes localize them visually. These ventilation shafts certainly guide also the owls' auditory search at times.

It might seem strange that rodents dig tunnels up to the snow surface, which makes them so vulnerable to avian predators. But because of respiration by bacteria, plants, and animals there is often an accumulation of CO₂ in the subnivean space, amounting to up to five times the atmospheric levels; and voles have been shown to avoid regions of high CO₂ concentrations (Penny and Pruitt 1984; p. 377). The tunnels dug by rodents to the snow surface therefore probably serve primarily to reduce CO₂ concentrations in their subnivean home-range.

Some of the northern owls store prey during winter, for instance in tree-holes or on branches near the day-roost. It is done particularly by the pygmy owl, *Glaucidium passerinum*, but occurs also among several others. This behavioural adaptation may be seen as a safeguard against future food shortage in an unpredictable environment, where unfavourable winter weather can drastically reduce prey availability.

Linked to this prey-caching in winter is a "prey thawing" behaviour that has been observed in captive boreal and saw-whet owls, *Aegolius funereus* and *A. acadicus*. When thawing frozen prey the owl assumes a posture on top of the prey similar to that during incubation of eggs; heat is transferred to the prey until it has thawed just enough to be eaten. The thawing of frozen prey involves a substantial energy drain to the owl but the behaviour is essential as it enables the owl to tear apart and eat prey that are stored at freezing temperatures (Bondrup-Nielsen 1977).

The male in *Aegolius funereus* usually makes a deep depression in the bottom material in hollow trees, sometimes a few weeks before the eggs are laid, often even before he has attracted a female. This is

usually the first sign of his nest-site selection (R. Å. Norberg 1964). The reshuffling of the bottom material, and the surface enlargement associated with the depression, speed up thawing, drying up, and warming of the bottom material before egg-laying. Moreover, the female usually stays in the nest for up to a week before laying (R. Å. Norberg 1964), which also may be important for warming the nest in a cold climate.

One additional aspect of evolution among northern owls is that the northward increasing prevalence of cyclic population fluctuations among prey may allow higher evolutionary rates than would otherwise be possible.

During a period of rapid population growth, conditions are obviously favourable. Some aspects of natural selection are therefore relaxed, which should lead to greater variability among the breeding population. This is because genetic variation is in equilibrium between mutation and recombination on the one hand and selection on the other. The survival and reproduction of animals that would not have survived under stricter selection regimes may permit genes to be tested in new genetic combinations. The great opportunities for new genetic recombinations to arise during a period of rapid population increase, followed by the extremely strong selection during the ensuing population decline, should allow more rapid evolution than with a more constant population density (Ford 1964, pp. 11-12). This factor might be important for the origin of ear asymmetry which seems to have occurred at high latitudes in some evolutionary lines among owls.

15. THE GREAT GREY OWL

I will make a few remarks particularly about the great grey owl which figures so prominently in this symposium, and very much so also behind its conception. I start by citing a Swedish naturalist, Erik Rosenberg, who characterized it as follows (my translation from Swedish): "The Great Grey Owl is almost as big as the European Eagle Owl and has a rather fantastic appearance. If the Eagle Owl looks like 'The Horny-headed Devil', then the Great Grey Owl resembles 'Tita Grey' - as may be known, a witch for whom the Devil had the greatest respect" (Rosenberg 1953).

The great grey owl has an enormously thick and fluffy plumage that gives very good thermal insulation against arctic winter temperatures. As a first approximation the great grey owl could be said to consist entirely of feathers! And its grey plumage is probably an adaptation for crypsis among the predominantly grey bark and lichens in the taiga forest. But the grey colour might also increase the thermoregulatory efficiency at low temperatures (see above: "3. Colour morphism").



Figure 23. - Composite picture with a photograph of the skull of a great grey owl superimposed on a photograph of the feathered head, showing the relative sizes of the skull and the facial ruffs and discs. - From Nero (1980, p. 76). Photograph obtained by courtesy of Dr. Robert W. Nero and Robert R. Taylor. Photos: R. R. Taylor.

The great grey owl has rather small eyes with yellow iris, which is unusual for a *Strix* species. The head and face are enormously large for the size of the owl, and the huge facial ruffs and discs are extremely well developed. Indeed, the whole face acts as an external ear, collecting sound over its entire surface area. This suggests the owl can detect very faint sounds made by prey underneath a deep snow cover.

The external ears are asymmetrical and the asymmetry extends also to the skull, the squamoso-occipital wings exhibiting an asymmetry very similar to that in *Strix uralensis*, but not by far as pronounced as in *Aegolius* (figs 8 and 9) (R. Å. Norberg 1977 and 1978).

The great grey owl takes remarkably small prey animals for its size. Indeed, even though it weighs about seven times as much as Tengmalm's owl, *Aegolius funereus*, which is sympatric with it over most of its range, its prey size as well as prey species composition are almost the same (Mikkola 1983, pp. 376, 377; Mueller 1986, p. 391). Not even during periods of extreme food shortage does the great grey owl resort to big prey; irruption owls that were found outside the breeding season in a more or less emaciated condition had not eaten anything but small rodents and shrews (*Microtidae* and *Sorex* spp.; Höglund and Lansgren 1968, pp. 391-394).



Figure 24. - The elusive "Phantom of the Northern Forest" (Nero 1980). - Photo: R. Åke Norberg.

This is in striking contrast with the strong correlations usually observed between raptor mass and prey mass among diurnal birds of prey, for instance among Accipiters (Storer 1966; Opdam 1975; Newton 1979; U. M. Norberg 1981, p. 182). Because of the large size of the great grey owl and its choice of small prey animals, it must take more prey per unit time than smaller owls do. This would seem to put it at a competitive disadvantage with respect to, for instance, *Aegolius funereus*.

Let us therefore look briefly at some compensatory advantages of the large size of the great grey owl. First, its extremely thick plumage should reduce its metabolic energy cost for thermoregulation. Second, its large external ears (essentially the whole face) should collect more sound energy than the ears of smaller owls, particularly for sounds of low frequencies. And since low-frequency sounds carry farther than do sounds of high frequencies (because of increasing diffraction and atmospheric attenuation with rising frequency), the detection distance of prey rustles should be particularly long in the great grey owl. Third, and again because of the large size of the face, interaural time differences are large and the asymmetry of the ears should allow horizontal and vertical localization already at relatively low frequencies, both factors enhancing the accuracy of localization of a sound source.

The mere size of the head and face thus enhances the probability of sound detection and improves localization accuracy. But once a prey that is concealed underneath vegetation, soil, or snow, has been detected, the owl's big size will again prove beneficial. Tryon (1943) saw a great grey owl strike at the ground with considerable force, apparently breaking through the roof of feeding runways in soil,



Figure 25. - The big size of the head and face of the great grey owl improves its probabilities of auditory detection of concealed prey and enhances localization accuracy. The asymmetry of the external ears improves sound localization in elevation. Its large weight enables it to make deep plunge-holes in the snow and to catch prey deep below the snow surface where lighter owls could not possibly get at the prey. The photographs show plunge-holes made in snow by the great grey owl. - Photographs obtained by courtesy of Dr. Robert W. Nero and Robert R. Taylor. Photos: R. R. Taylor.



and catching pocket gophers, *Thomomys talpoides*, in their burrows. Goodfrey (1967) reported on a great grey owl catching prey under 20 cm of soft snow. Nero (1980, pp. 89-93) described how great grey owls pounced at prey concealed under snow, and showed photographs taken by Robert R. Taylor (some of which appear in my fig. 25) showing deep plunge-holes, indicating that the great grey owl can get at prey that is moving beneath such deep snow

that lighter owls could not possibly reach it. And, finally, Hildén and Helo (1981, p. 164) showed photographs taken by Eero Kemilä of a striking great grey owl that almost disappeared in the snow, and they also reported an observation by T. Korkolainen who witnessed a great grey owl which plunged through a snow crust hard enough to bear a 80-kg man.

So even though the great grey owl does not use its large size to take big prey, it obviously benefits from its size in other ways.

16. EPILOGUE

Before I stop entirely, I want to add the following. For me to come to this symposium in Winnipeg and talk about the great grey owl and other owls is like "carrying owls to Athens". This is a Greek proverb based on the fact that owls, in particular the Little Owl, *Athene noctua*, were very common around the city of Athens in Greece (Sparks and Soper, 1970, p.161).

But on my way here I met a Greek on the plane, Anastasios Christodoulou. I asked him about this proverb and he gave a different interpretation of it. This relates to the owl being a symbol of wisdom. And since there was so much wisdom in ancient Athens already, there was no need of "carrying owls" there. This very much applies to my situation here at this symposium.

Acknowledgements. - I thank Robert W. Nero and Robert R. Taylor for providing the photographs shown in figures 24 and 25 and for their permission to reproduce them; my wife Ulla M. Norberg for commenting on the manuscript; and Robert H. Hamre for editorial help. The study was supported by grants from the Swedish Natural Science Research Council (No. B 4450).

LITERATURE CITED

- Andersson, M. 1980. Nomadism and site tenacity as alternative reproductive tactics in birds. - *Journal of Animal Ecology* 49:175-184.
- Andersson, M. 1981. On optimal predator search. - *Theoretical Population Biology* 19:58-86.
- Andersson, M. and Norberg, R. Å. 1981. Evolution of reversed sexual size dimorphism and role partitioning among predatory birds, with a size scaling of flight performance. - *Biological Journal of the Linnean Society* 15:105-130.
- Barrows, C. W. 1981. Roost selection by spotted owls: an adaptation to heat stress. - *Condor* 83:302-309.
- Bondrup-Nielsen, S. 1977. Thawing of frozen prey by boreal and saw-whet owls. - *Canadian Journal of Zoology* 55:595-601.
- Brehm, W. 1922. *Brehms Tierleben*. Vol. 8 & 11. - Bibliographisches Institut. Leipzig. (In German.)
- Burton, J. A. 1973. *Owls of the World. Their Evolution, Structure and Ecology*. - Peter Lowe. Eurobook Limited.
- Cade, T. J. 1982. *The Falcons of the World*. - Cornell University Press, Ithaca.
- Clark, R. J., Smith, D. G., and Kelso, L. H. 1978. *Working Bibliography of Owls of the World - NWF Scientific/Technical Series No. 1*. National Wildlife Federation, Washington, D. C.
- Collett, R. 1871. On the asymmetry of the skull in *Strix tengmalmi*. - *Proceedings of the Zoological Society of London* 1871:739-743.
- Collett, R. 1872. Om craniets assymetri hos *Nyctala tengmalmi*, Gm. - *Christiania Videnskabselskabs Forhandling* 1872: 68-72. (In Norwegian. Content essentially as in Collett 1871.)
- Collett, R. 1881. Craniets og øreaabningernes bygning hos de nordeuropaeiske arter af familien Strigidae. - *Christiania Videnskabselskabs Forhandling* 1881, No. 3:1-38. (In Norwegian. An unabridged English version was given by Shufeldt 1901a, who also added some notes.)
- Craighead, J. J. and Craighead, F. C. Jr. 1956. *Hawks, Owls, and Wildlife*. - Stackpole Company and Wildlife Management Institute. Reprinted 1969 by Dover Publications, New York.
- Darwin, C. 1871. *The Descent of Man and Selection in Relation to Sex*. - John Murray. London.
- Dawkins, R. 1976. *The Selfish Gene*. - Oxford University Press, Oxford.
- Earhart, C. M. and Johnson, N. K. 1970. Size dimorphism and food habits of North American owls. - *Condor* 72:251-264.
- Erlinge, S., Göransson, G., Hansson, L., Högstedt, G., Liberg, O., Nilsson, I. N., Nilsson, T., von Schantz, T., and Sylvén, M. 1983. Predation as a regulating factor on small rodent populations in southern Sweden. - *Oikos* 40:36-52.
- Fogden, M. 1973. Fishing owls, eagle owls and the snowy owl. *Ketupa, Scotopelia, Bubo, Nyctea*. Pp. 61-93 In: Burton, J. A. 1973. *Owls of the World. Their Evolution, Structure and Ecology*. - Peter Lowe. Eurobook Limited.
- Ford, E. B. 1964. *Ecological Genetics*. - Methuen, London.
- Forsman, E. D., Meslow, E. C., and Wight, H. M. 1984. Distribution and biology of the spotted owl in Oregon. - *Wildlife Monographs* No. 87.
- Ginn, H. 1973. Little, pygmy and elf owls. *Athene, Speotyto, Micrathene, Glaucidium, Aegolius, Pseudoscops*. Pp. 164-185 In: Burton, J. A. 1973. *Owls of the World. Their Evolution, Structure and Ecology*. - Peter Lowe. Eurobook Limited.
- Goodfrey, W. E. 1967. Some winter aspects of the great gray owl. - *Canadian Field-Naturalist* 81:99-101.
- Graham, R. N. 1934. The silent flight of owls. - *Journal of the Royal Aeronautical Society* 38:837-843.
- Gruschka, H. D., Borchers, I. U. and Coble, J. G. 1971. Aerodynamic noise produced by a gliding owl. - *Nature* 233:409-411.
- Hagen, Y. 1952. *Rovfuglene of Viltpleien*. - Gyldendal Norsk Forlag, Oslo. (In Norwegian)
- Hansson, L. 1984. Predation as the factor causing extended low densities in microtine cycles. - *Oikos* 43:255-256.

- Hansson, L. and Henttonen, H. 1985. Gradients in density variations of small rodents: the importance of latitude and snow cover. - *Oecologia* (Berlin) 67:394-402.
- Hasbrouck, E. M. 1893. Evolution and dichromatism in the genus *Megascops*. - *American Naturalist* 27:638-649.
- Hekstra, G. P. 1973. Scops and screech owls. *Otus*, *Lophostrix*. Pp. 94-115 In: Burton, J. A. 1973. Owls of the world. Their Evolution, Structure and Ecology. - Peter Lowe. Eurobook Limited.
- Henttonen, H. 1985. Predation causing extended low densities in microtine cycles: further evidence from shrew dynamics. - *Oikos* 45:156-157.
- Hertel H. 1966. Structure, Form, Movement. - Reinhold Publishing Corporation, New York.
- Hildén, O. and Helo, P. 1981. The great grey owl *Strix nebulosa* - a bird of the northern taiga. - *Ornis Fennica* 58:159-166.
- Hirschberger, W. 1967. Histologische Untersuchungen an den primären visuellen Zentren des Eulengehirnes und der retinalen Repräsentation in ihnen. - *Journal für Ornithologie* 108:187-202. (In German.)
- Höglund, N. H. and Lansgren, E. 1968. The great grey owl and its prey in Sweden. - *Viltrevy* 5:364-421.
- Hrubant, H. E. 1955. An analysis of the color phases of the eastern screech owl, *Otus asio*, by the gene frequency method. - *American Naturalist* 89:223-230.
- Jägerskiöld, L. A., Lönnberg, E., and Adlerz, G. 1903. Sveriges Djurvärld. - Aftonbladet, Stockholm. (In Swedish.)
- Järvinen, A. 1985. Predation causing extended low densities in microtine cycles: implications from predation on hole-nesting passerines. - *Oikos* 45:157-158.
- Karten, H. J., Hodos, W., Nauta, W. J. and Revzin, A. M. 1973. Neural connections of the "visual Wulst" of the avian telencephalon. Experimental studies in the pigeon (*Columba livia*) and owl (*Speotyto cunicularia*). - *Journal of Comparative Neurology* 150:253-278.
- Knudsen, E. I. 1981. The hearing of the barn owl. - *Scientific American* 245:113-125.
- Knudsen, E. I. 1980. Sound localization in birds. Pp. 289-322 In: Popper, A. N. and Fay, R. R. (eds). *Comparative Studies of Hearing in Vertebrates*. - Springer, New York.
- Knudsen, E. I., Blasdel, G. G., and Konishi, M. 1979. Sound localization by the barn owl (*Tyto alba*) measured with the search coil technique. - *Journal of Comparative Physiology* 133:1-11.
- Knudsen, E. I. and Konishi, M. 1978. A neural map of auditory space in the owl. - *Science* 200:795-797.
- Knudsen, E. I. and Konishi, M. 1979. Mechanisms of sound localization in the barn owl (*Tyto alba*). - *Journal of Comparative Physiology* 133:13-21.
- Korpimäki, E. 1986. Reversed size dimorphism in birds of prey, especially in Tengmalm's owl *Aegolius funereus*: a test of the "starvation hypothesis". - *Ornis Scandinavica* 17:326-332.
- Korpimäki, E., Lagerström, M., and Saurola, P. 1987. Field evidence for nomadism in Tengmalm's owl *Aegolius funereus*. - *Ornis Scandinavica* 18:1-4.
- Krebs, C. J., Gaines, M. S., Keller, B. L., Myers, J. H., and Tamarin, R. H. 1973. Population cycles in small rodents. - *Science* 179:35-41.
- Lighthill, J. 1977. Introduction to the scaling of aerial locomotion. Pp. 365-404 In: Pedley, T. J. (ed.) 1977. *Scale Effects in Animal Locomotion*. - Academic Press, London.
- Löfgren, O., Hörnfeldt, B., and Carlsson, B.-G. 1986. Site tenacity and nomadism in Tengmalm's owl (*Aegolius funereus* (L.)) in relation to cyclic food production. - *Oecologia* (Berlin) 69:321-326.
- Lundberg, A. 1979. Residency, migration and a compromise: adaptations to nest-site scarcity and food specialization in three Fennoscandian owl species. - *Oecologia* 41:273-281.
- Lundberg, A. 1980. Why are the ural owls *Strix uralensis* and the tawny owl *S. aluco* parapatric in Scandinavia? - *Ornis Scandinavica* 11:116-120.
- Lundberg, A. 1986. Adaptive advantages of reversed sexual size dimorphism in European owls. - *Ornis Scandinavica* 17:133-140.
- Lüers, H. and Ulrich, H. 1959. Genetik und Evolutionsforschung bei Tieren. Pp. 552-661 In: Heberer, G. *Die Evolution der Organismen. Ergebnisse und Probleme der Abstammungslehre*. - Gustav Fisher Verlag, Stuttgart. (In German.)
- Magnus, O. 1555. *Historia de Gentibus Septentrionalibus*. - Rome. Swedish edition 1976: *Historia om de Nordiska Folken*. - Gidlunds Förlag. (In Swedish.)
- Martin, G. R. 1974. Color vision in the tawny owl (*Strix aluco*). - *Journal of Comparative and Physiological Psychology* 86:133-141.
- Martin, G. R. 1977. Absolute visual threshold and scotopic spectral sensitivity in the tawny owl, *Strix aluco*. - *Nature* 268:636-638.
- Martin, G. R. 1986. Sensory capacities and the nocturnal habit of owls (*Strigiformes*). - *Ibis* 128:266-277.
- Martin, N. D. 1950. Color phase investigations on the screech owl in Ontario. - *Canadian Field-Naturalist* 64:208-211.
- Marshall, J. T. Jr. 1967. Parallel variation in North and Middle American screech-owls. - *Monographs of the Western Foundation of Vertebrate Zoology*, No. 1.
- Marshall, J. T. Jr. 1978. Systematics of smaller Asian night birds based on voice. - *Ornithological Monographs* No. 25. The American Ornithologists' Union.
- Mayr, E. 1965. *Animal Species and Evolution*. - Harvard University Press, Cambridge.
- McGillivray, W. B. 1985. Size, sexual size dimorphism, and their measurement in great horned owls in Alberta. - *Canadian Journal of Zoology* 63:2364-2372.
- Mikkola, H. 1983. *Owls of Europe*. - T. & A. D. Poyser, Calton.
- Moreau, R. E. 1972. *The Palearctic-African Bird Migration Systems*. - Academic Press, London.
- Mosher, J. A. and Henny, C. J. 1976. Thermal adaptiveness of plumage color in screech owls. - *Auk* 93:614-619.
- Mueller, H. C. and Meyer, K. 1985. The evolution of reversed sexual dimorphism in size; a comparative analysis of the falconiformes of the western Palearctic. Pp. 65-101 In: Johnston, R. F. (ed.). *Current Ornithology*. Vol. 2. - Plenum Press.

- Mueller, H. C. 1986. The evolution of reversed sexual dimorphism in owls: an empirical analysis of possible selective factors. - *Wilson Bulletin* 98:387-406.
- Mysterud, I. 1970. Hypotheses concerning characteristics and causes of population movements in Tengmalm's owl (*Aegolius funereus*). - *Nytt Magasin for Zoologi* 18:49-74.
- Mysterud, I. and Dunker, H. 1979. Mammal ear mimicry: a hypothesis on the behavioural function of owl "horns". - *Animal Behaviour* 27:315-316.
- Nero, R. W. 1980. The Great Gray Owl. Phantom of the Northern Forest. - Smithsonian Institution Press, Washington, D.C.
- Neuhaus, W., Bretting, H. and Schweizer, B. 1973. Morphologische und funktionelle Untersuchungen über den "lautlosen" Flug der Eulen (*Strix aluco*) im Vergleich zum Flug der Enten (*Anas platyrhynchos*). - *Biologisches Zentralblatt* 92:495-512. (In German.)
- Newton, I. 1979. Population Ecology of Raptors. - T. & A. D. Poyser, Berkhamsted.
- Newton, I. 1986. The Sparrowhawk. - T. & A. D. Poyser, Calton.
- Norberg, R. Å. 1964. Studies on the ecology and ethology of Tengmalm's owl (*Aegolius funereus*). - *Vår Fågelvärld* 23:228-244. (In Swedish, summary in English.)
- Norberg, R. Å. 1968. Physical factors in directional hearing in *Aegolius funereus* (Linné)(Strigiformes), with special reference to the significance of the asymmetry of the external ears. - *Arkiv för Zoologi* 20:181-204.
- Norberg, R. Å. 1970. Hunting technique of Tengmalm's owl *Aegolius funereus* (L). - *Ornis Scandinavica* 1:51-64.
- Norberg, R. Å. 1973. Directional hearing in man and in an owl with bilaterally asymmetrical external ears. - *Swedish Natural Sciences. Yearbook of the Swedish Natural Science Research Council* 1973, 26: 89-101. - Stockholm. (In Swedish, summary in English.)
- Norberg, R. Å. 1977. Occurrence and independent evolution of bilateral ear asymmetry in owls and implications on owl taxonomy. - *Philosophical Transactions of the Royal Society of London. B.* 280:375-408.
- Norberg, R. Å. 1978. Skull asymmetry, ear structure and function, and auditory localization in Tengmalm's owl, *Aegolius funereus* (Linné). - *Philosophical Transactions of the Royal Society of London. B.* 282:325-410.
- Norberg, R. Å. 1981. Temporary weight decrease in breeding birds may result in more fledged young. - *The American Naturalist* 118:838-850.
- Norberg, R. Å. In press. Theory of growth geometry in plants and self-thinning of plant populations; geometric similarity, elastic similarity, and different growth modes of plant parts. - *The American Naturalist*.
- Norberg, U. M. 1981. Flight, morphology and the ecological niche in some birds and bats. Pp. 173-197 In Day, M. H. (ed.) *Vertebrate locomotion. Symposia of the Zoological Society of London No. 48.* - Academic Press, London.
- Norberg, U. M. 1985. Flying, gliding, and soaring. Pp. 129-158 in Hildebrand, M., Bramble, D. M., Liem, K. F., and Wake, D. B. (Eds) *Functional vertebrate morphology.* - Harvard University Press, Cambridge, Massachusetts.
- Norberg, U. M. and Rayner, J. M. V. 1987. Ecological morphology and flight in bats (Mammalia; Chiroptera): Wing adaptations, flight performance, foraging strategy and echolocation. - *Philosophical Transactions of the Royal Society, of London. B.* In press.
- Norberg, U. M. and Norberg, R. Å. In press. Ecomorphology of flight and tree-trunk climbing in birds. - *Proceedings of the 19th International Ornithological Congress, Ottawa, 1986.*
- Olsen, P. and Olsen, J. 1984. Book review: Cade, T. J. 1982. *The Falcons of the World.* Cornell University Press, Ithaca. - *Australian Wildlife Research* 11:205-206.
- Opdam, P. 1975. Inter- and intraspecific differentiation with respect to feeding ecology in two sympatric species of the genus *Accipiter*. - *Ardea* 63:30-54.
- Payne, R. S. 1962. How the barn owl locates prey by hearing. - *Living Bird* 1:151-159
- Payne, R. S. 1971. Acoustic location of prey by barn owls (*Tyto alba*). - *Journal of Experimental Biology* 54:535-573.
- Penny, C. E. and Pruitt, W. O. Jr. 1984. Subnivean accumulation of CO₂ and its effects on winter distribution of small mammals. Pp. 373-380 In: Merritt, J. F. (ed.) *Winter Ecology of Small Mammals.* - Special publication of Carnegie Museum of Natural History. No 10. Pittsburgh.
- Perrone, M. Jr. 1981. Adaptive significance of ear tufts in owls. - *Condor* 83:383-384.
- Peters, J. L. 1940. Check-list of Birds of the World. Vol.4. - Harvard University Press, Cambridge. Reprinted 1964 by Museum of Comparative Zoology, Harvard University Press, Cambridge.
- Peterson, R. T. 1961. *A Field Guide to Western Birds.* - Houghton Mifflin Company, Boston.
- Pettigrew, J. D. 1979. Binocular visual processing in the owl's telencephalon. - *Proceedings of the Royal Society of London. B* 204:435-454.
- Pumphrey, R. J. 1948. The sense organs of birds. - *Annual Report of the Smithsonian Institution* 1948:305-330.
- Reynolds, R. T. 1972. Sexual size dimorphism in *Accipiter* hawks: a new hypothesis. - *Condor* 74:191-197.
- Roberts, T. J. and King, B. 1986. Vocalizations of the owls of the genus *Otus* in Pakistan. - *Ornis Scand.* 17: 299-305.
- Rosenberg, E. 1953. *Fåglar i Sverige.* - Svensk Natur, Stockholm. (In Swedish.)
- Safina, C. 1984. Selection for reduced male size in raptorial birds: the possible roles of female choice and mate guarding. - *Oikos* 43:159-164.
- Scherzinger, W. 1983. Beobachtungen an Waldkauz-Habichtskauz-Hybriden (*Strix aluco* X *Strix uralensis*). - *Zool. Garten N. F., Jena* 53:133-148. (In German.)
- Schultze, M. 1867. Über Stabchen und Zapfen der Retina. - *Archiv für mikroskopische Anatomie und Entwicklungsmechanik* 3:215-247. (In German.)
- Schwartzkopff, J. 1968. Structure and function of the ear and of the auditory brain areas in birds. Pp. 41-63 In: DeReuck, A. V. S. and Knight, J. (eds).

- Hearing Mechanisms in Vertebrates. A Ciba Foundation Symposium. - J. & A. Churchill, London.
- Shufeldt, R. W. 1901a. Professor Collett on the morphology of the cranium and the auricular openings in the North-European species of the family Strigidae. - *Journal of Morphology* 17:119-176.
- Shufeldt, R. W. 1901b. On the osteology of the Striges (Strigidae and Bubonidae). - *Proceedings of the American Philosophical Society* 39:665-722.
- Sick, H. 1937. Morphologisch-Funktionelle Untersuchungen über die Feinstruktur der Vogelfeder. - *Journal für Ornithologie* 85:206-372. (In German.)
- Snyder, N. F. R. and Wiley, J. W. 1976. Sexual size dimorphism in hawks and owls of North America. *Ornithological Monographs* No. 20. - The American Ornithologists' Union.
- Sonerud, G. A. 1986. Effect of snow cover on seasonal changes in diet, habitat, and regional distribution of raptors that prey on small mammals in boreal zones of Fennoscandia. - *Holarctic Ecology* 9:33-47.
- Sparks, J. and Soper, T. 1970. Owls. Their Natural and Unnatural History. - David & Charles. Newton Abbot
- Steinbach, M. J. and Money, V. E. 1973. Eye movements of the owl. - *Vision Research* 13:889-891.
- Storer, R. W. 1966. Sexual dimorphism and food habits in three North American accipiters. - *Auk* 83:423-436.
- Streets, T. H. 1870. Remarks on the cranium of an owl. - *Proceedings of the Academy of Natural Sciences of Philadelphia* 1870:73.
- Stresemann, E. 1934. Sauropsida: Aves. In: *Handbuch der Zoologie* (Küekenthal and Krumbch, eds). Vol. 7/2. - Berlin, Leipzig. (In German.)
- Svärdson, G. 1949. Competition and habitat selection in birds. - *Oikos* 1:157-174.
- Thorpe, W. H. and Griffin, D. R. 1962. The lack of ultrasonic components in the flight noise of owls compared with other birds. - *Ibis* 104:256-257.
- Tryon, C. A. 1943. The great grey owl as a predator on pocket gophers. - *Wilson Bulletin* 55: 130-131.
- Walker, E. P. 1964. *Mammals of the World*. Vol. 1. - The John Hopkins Press, Baltimore.
- Wallin, K. and Andersson, M. 1981. Adult nomadism in Tengmalm's owl *Aegolius funereus*. - *Ornis Scandinavica* 12:125-126.
- Walter, H. 1979. *Eleonora's Falcon, Adaptations to Prey and Habitat in a Social Raptor*. - Chicago University Press, Chicago.
- Wesslén, S. 1941. *Då Rovdjuret Vakar*. - Norstedts, Stockholm. (In Swedish.)
- Williams, G. C. 1966. *Adaptation and Natural Selection*. - Princeton University Press, Princeton.

A Second Chance for Owls (Banquet Address)¹

Katherine McKeever²

The use of permanently damaged wild owls for captive breeding, although difficult to implement, has great merit in providing intimate, continuous observations of how owls use space, avoid stress and form effective pair bonds when multiple choices are available. Surrogate parenting of wild orphans by human imprints is also examined.

The Owl Rehabilitation Research Foundation is situated on the west bank of the Jordan River Estuary, two miles south of Lake Ontario, twenty miles west of Niagara Falls in Ontario Canada. Of the eight acres (3.25 hectares) owned by the Foundation, six acres are on level ground 100 feet (31 metres) above the estuary and two acres slope to the valley floor. This slope supports a remnant Carolinian wood lot of mature Red and White Oak, Hickory, White Pine, Walnut, Dogwood and Tulip Magnolia.

Incorporated as a registered charitable Foundation in 1975, the organization really began a decade earlier as a reception and rehabilitation centre for injured raptorial birds. In the years since, the emphasis first shifted to admission of owls exclusively and then to consideration of the wasted potential in those owls with injuries which precluded release but not restoration of health.

Although the returning ability to function in release is still rewarded with freedom, those owls for which freedom can never be an option are assessed very critically for their potential in a captive breeding program. Obviously, there is little purpose in retaining members of naturally abundant species for further proliferation in such a program, but the Foundation houses several pairs of the most commonly encountered owls as foster parents for incoming orphaned young of these species.

However, permanently damaged members of naturally rare or diminishing species are the prime candidates for a captive breeding program. Much of the available land and income of the Foundation is involved in this endeavour. Currently, there are 54

outdoor compounds, ranging from 200 to 3,500 square feet each (18.58 to 325.15 square metres), the average being 600 to 900 square feet (55.74 to 83.61 square metres). The 41 largest of these are ~~double~~ territory breeding compounds and 13 are holding and release-training areas. The breeding units presently house 86 permanently damaged residents, representing the 15 Canadian species. To date, 9 of these species have successfully bred on the premises, with infertile eggs following attempted copulation from 3 more. (table 1)

Although the fact of these owls having achieved independence in the wild before being injured obviously renders them the most unlikely and difficult prospect for captive breeding (not to mention the

Table 1. -- Owl species native to Canada, all of which are represented at the Owl Rehabilitation Research Foundation.

Common name	Genus and Species	Resident
American Barn Owl*	Tyto alba	2
Screech Owl *	Otus asio	9
Flammulated Owl [†]	Otus flammeolus	5
Great Horned Owl*	Bubo virginianus	6
Snowy Owl*	Nyctea scandiaca	7
Northern Hawk Owl [†]	Surnia ulula	6
Northern Pygmy Owl*	Glaucidium gnoma	7
Spotted Owl [†]	Strix occidentalis	2
Barred Owl [†]	Strix varia	6
Great Grey Owl*	Strix nebulosa	7
Long Eared Owl	Asio otus	2
Short Eared Owl	Asio flammeus	5
Boreal Owl*	Aegolius funereus	6
Saw-whet Owl*	Aegolius acadicus	8
Burrowing Owl*	Athene cunicularia	8

*Species which have produced offspring.

[†]Species which have produced eggs only.

¹Paper presented at the symposium, Biology & Conservation of Northern Forest Owls, Feb. 3-7, 1987, Winnipeg, Manitoba. USDA Forest Service General Technical Report RM-142.

²Dr. Katherine McKeever, Director, The Owl Rehabilitation Research Foundation, R.R.#1 Vine-land Station, Ontario, Canada. LOR 2EO

physical limitations imposed by their injuries) success is both justifying and intensely interesting. The very fact of their intransigent wildness makes them valuable beyond any comparison with domestic stock.

Selecting that part of the acreage which most closely resembles the habitat of the species (Fig.1) the challenge to this Foundation has been to design and erect breeding compounds of such size and diversity that they offer every imaginable choice to the wild occupant. (Fig.2)

Just as the provision of choice is the most critical ingredient in any enclosure for wild owls, it is also the most important aspect of their relationship with a potential mate. Thus, having provided continuous perimeter flight paths as 'escape routes' for the male, it is encouraging to see that his approach to the female is made confident by his awareness of that escape route, whether or not he is ever obliged to use it. The whole process of being able to choose, whether it be a territory, a nest site, a favoured perch, a private food source or just being able to get away from each other, is the route to psychological security for the permanently damaged wild owl and the ONLY route that will lead, ultimately, to spontaneous breeding.

Human interference at the Foundation is pared to the absolute minimum possible. Nesting areas are never entered during the season, except in a medical emergency. Pools are serviced and prey provided in hunting areas only. Eye contact is avoided and observations are made from screened areas. The Foundation is never open to the public and visitation is by appointment only.

All progeny hatched on these premises are raised entirely by their natural parents, away from the sight of, or interference by, humans and are as wild as their parents. They are handled only twice,



Figure 1.--One corner of 800 sq.ft.(74.32 metres) breeding compound for one pair of Spotted Owls (*Strix occidentalis*). Downhill face is 17' high (5.23 metres).

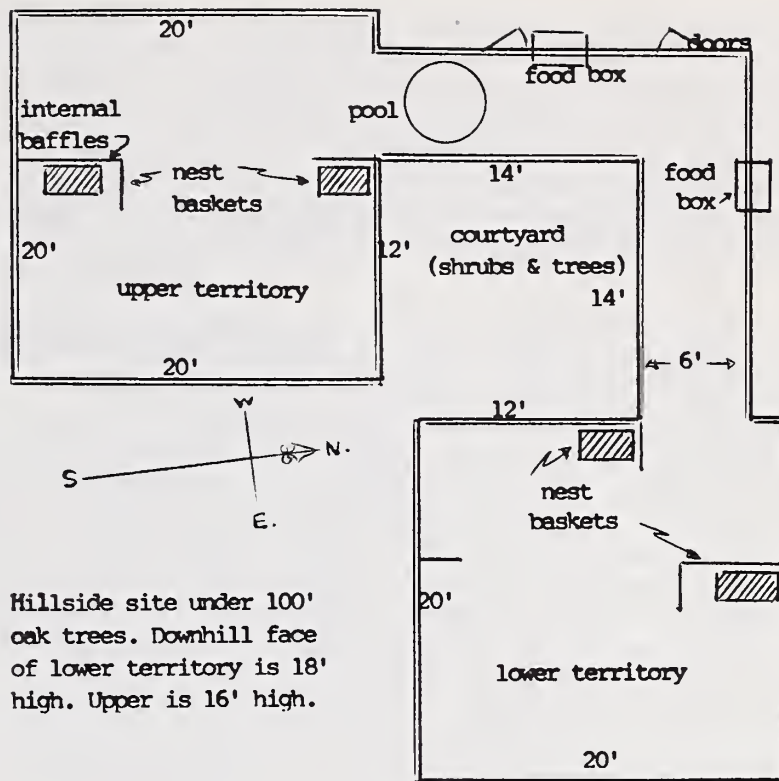

Hillside site under 100' oak trees. Downhill face of lower territory is 18' high. Upper is 16' high.

Figure 2.--Design of 1,004 sq.ft. (92.9 metres) compound in which one pair of damaged Great Grey Owls (*Strix nebulosa*) have bred.

once when they are removed to release-training compounds, and for the last time when they are banded and shipped for release to the area where one of their parents originated. The release-training itself involves four weeks of learning to forage for unseen live prey under suitable cover and for the more nocturnal species especially it accomplishes the transition from visually perceived prey to that located by sound reception. Owls which fail to demonstrate this ability, whether hatched here, received as orphans or following rehabilitation are not released.

Beyond the utilization of physically damaged wild owls in a breeding program, there is also a very positive function provided by owls which are damaged in a different way - by disorder of their relationship formation with their own species and orientation towards human life forms instead. The Foundation has received a number of such human imprints over the years and three of them are among the most useful owls we have ever admitted. Two of these, a male Great Horned Owl and a male Screech Owl are themselves members of locally common owl species and each year provide both sustenance and imprint re-inforcing for incoming fledgelings of their species.

Since the human imprinted adults are easily manipulated by their human 'mates', they serve in an intermediate capacity between the human on one hand and the wild but still vulnerable juvenile on the other, and make it possible for the human to control the nutrition of the young owl without the danger of being visible to it during the imprinting period. Species imprinting is safely established

when the young owl clearly recognizes the DIFFERENCE between the image of the 'safe' parent and that of other animate life forms. This milestone is marked by instinctive defense posturing and beak snapping when the owlet is confronted by an alien image. Thus safely oriented towards their own species, the young are then processed through the facility along with those hatched on the premises.

The third human imprint owl in service at the Foundation is in many ways the most useful of all, by virtue of being a female of a medium-sized species (Spectacled Owl; *Pulsatrix perspicillata*). Encouraged by her human 'mate', with grooming and hand feeding, to produce an egg at the beginning of the ambient nesting season for native owls, she will then accept any other egg of even faintly similar size and incubate it faithfully to hatch. Although a model incubator, superior to any mechanical device, she truly excels at motherhood! It is the author's contention that the psychological security developed in the nestling infant by the solicitous brooding mother is just as critical to future performance of the owl as it is to that of primates and humans. (Fig.3)

The only limitation in using this remarkable owl as a surrogate parent is that before visual focus is achieved the nestling must be transferred to the care of an adult of its own species. Indeed, the Spectacled Owl is often by-passed as a foster parent when breeding residents of the orphan's own species are brooding young of comparable size. The Spectacled Owl can be seen as insurance against the day when incompatible eggs or orphans are presented. Nevertheless, in one memorable year, this owl 'processed' five nestlings of four species over a four and a half month period, in each case



Figure 3.--Human imprint Spectacled Owl (*Pulsatrix perspicillata*) brooding Barn Owl (*Tyto alba*) chick which she has incubated to hatch.

reverting to appropriate feeding for a newly hatched infant and raising it through degrees to the point of swallowing whole prey!

In reviewing the justification for a captive establishment for permanently damaged WILD owls, the author recognizes that the best that can be achieved will never be as effective as leaving the owl alone, undamaged, in his own environment. Obviously, this will always be second best, really only salvage and tenuous at that. But it is better than doing nothing about the carnage, and it does offer intimate and continuous observations of the kind not easily supported in the field. Patterns of behaviour in individual owls are so strong that one can predict where the owl will be and what he will be doing at almost any time of day or evening. Anomalies in these patterns can then be studied for their origin and manifestation and especially for their indications of change. Our residents live long lives and go about their daily activities, crippled but not defeated, constantly trying and sometimes succeeding in passing on their genes so that their progeny can be released in their place. (Fig.4)

It is always deeply satisfying to return to the wild population some part of the genetic diversity diminished by the injury to the parent. It is even more rewarding to see the capacity for survival and function in a truly wild raptor when dignity is regained through the ability to make choices. Returning self confidence allows the damaged raptor to resume his inherent behavioral patterns of territorial defence and mate solicitation, even though, of necessity, under the umbrella of protective captivity.



Figure 4.--Partially fledged siblings from breeding pair of permanently damaged wild Saw-whet Owls (*Aegolius acadicus*).

Distributional Status and Literature of Northern Forest Owls¹

Richard J. Clark,² Dwight G. Smith,³ and Leon Kelso⁴

Abstract.--The literature for the 22 species of owls designated as "Northern Forest Owls" [for purposes of this symposium] was examined via analysis of 6,590 articles cited in Clark, Smith and Kelso (1978) plus an additional, estimated 3500 references. Articles were categorized according to geographic location, chronology, informational content and species. While some general trends were identified no single factor could satisfactorily explain the presence or absence of quantities of articles dealing with each species. Based on the summary of the literature and this symposium five (5) owl species are identified as "species of special concern" for researchers, wildlife specialists and land managers.

INTRODUCTION

This report deals with all 22 of the species designated by the conference committee for this conference as northern forest owls, i.e., those species associated with the forest and with the 35th parallel designated as their southern border. Any species occurring wholly below this line has not been considered a "northern forest owl." The scientific literature on the 22 species of northern forest owls is published in the journals, bulletins and other formats of a number of publications throughout the world with those of Eurasia and North American countries predominating because of the ranges of the species and human population centers. Some literature, especially the early literature published prior to the advent of abstracting services, is not readily available and therefore usually not as well known. In addition, the literature on owls published in eastern European countries is generally not easily accessed by North American

Strigiologists and probably the reverse is also true.

Our bibliography of owl literature (Clark *et al.* 1978) included 6590 references on the published literature of all the world's owl species known at that time. To this we have added approximately 3500 additional references, many of them published since 1978. Using this reference data base, we herein (1) summarize the extent and distribution of the available literature on northern forest owl species; (2) describe the temporal and geographic origin of this literature; and (3) provide brief summaries of the literature trends per species. Based on this analysis, we describe the major categories of literature published on each species and provide an inventory of logical areas of research not yet investigated. We also describe the distributional status and range of each species.

METHODS

Information on the range and distributional status of each of the northern forest owls was determined from the literature. For some species the range was plotted from several published sources. The geographical area occupied by each species was determined by tracing the range on standard survey maps, cutting the plotted range, weighing the cutout on a Mettler PC2000 digital balance and comparing the weight with a

¹Paper presented at the symposium, Biology and Conservation of Northern Forest Owls, Feb. 3-7, 1987, Winnipeg, Manitoba. USDA Forest Service General Technical Report RM-142.

²Richard J. Clark is Professor of Biology at York College of Pennsylvania, York, Pa. 17403-3426.

³Dwight G. Smith is Professor of Biology at Southern Connecticut State University, New Haven, Conn. 06515

⁴Deceased.

known area/weight ratio. Results provided a basis for the comparison of the areal coverage of each northern forest owl species range. This method does not, of course, take into consideration the fact that not all areas within the boundaries delimited on such a map will possess suitable habitat for that particular species. The results are thus only rough approximations of extent of geographic distribution. Information on the literature of each owl species was determined using methods described in Clark *et al.* (1978). Briefly, we extracted the references using computer search services [such as the suitable data bases within Lockheed's DIALOG], checking abstracting publications including Zoological Record and Biological Abstracts and searching journals issue by issue. Most of the estimated 3500 new references were obtained from this source with many having been obtained by authors or researchers having sent the senior author listings of references not listed in Clark *et al.* (1978). Data obtained for each reference included authorship, date of publication, journal or other publication format, topics covered and geographic locale of the observation or investigation.

Topic coverage [which we have termed "ASPECT"] of each article was assigned as one or more of eight broad categories: "ecology", "behavior", "distribution", "taxonomy", "physiology", "anatomy", "conservation" and "general". Many articles included information which was assigned to several categories. The "general" category was limited to articles which were primarily intended for a nonscientific audience.

Each article was also assigned an appropriate code indicating the GEOGRAPHIC LOCATION for the report. There were 112 listings with Australia, Canada and the United States being broken down into states or provinces. This was done because the literature from those areas tended to be more recent and the political boundaries somewhat more stable.

In addition each article was also assigned an appropriate code indicating the Genera or Genus for the report. There is a considerable problem with this because of difficulties associated with the dynamics of nomenclature and changes in taxonomy resulting from new knowledge of the taxonomic relationships of owl species. One example should suffice to reveal the nature of these problems, e.g., our table entitled "Common names of owls in selected foreign languages," lists 39 common names for *Otus* *scops* and 41 common names for *Strix* *aluco*.

RESULTS

Distribution and Status

General works which describe the distribution and ecology of owls, including the northern forest owls is presented in Burton (1973) and Grossman and Hamlet (1966). The owls of Europe are described in greater detail by Mikkola (1983) and of Asia by Dement'ev *et al.* (1966).

A summary of the distribution, ecological habitat and status of the 22 species of northern forest owls is presented in Table 1. The Long-eared Owl, Hawk Owl, Great Gray Owl and Boreal Owl are holarctic, occurring in both new and old world hemispheres. Of these, the Long-eared Owl is the most wide-ranging and encompasses the largest geographical area of any species of northern forest owl. The Great Gray Owl, Boreal Owl and Hawk Owl may more correctly be classed as circumboreal since they occupy coniferous forest habitat and its successional stages, except during their southward incursions. Although more restricted in distribution, the Eagle Owl, Great Horned Owl and Scops Owl also have a wide areal range coverage. All three may be considered habitat generalists. The Eagle Owl occurs in a wide variety of habitats in Europe, Asia and Africa while its new world kin, the Great Horned Owl, occupies deciduous, coniferous, mixed and riparian woodlands, desert scrub, and other habitats in North, Central and South America. The Saw-whet Owl is something of an exception to the rule that an owl must be a generalist to have a large areal range coverage. Being a wide-ranging species in North America, it occurs mostly in conifer or mixed woodland. This species has a comparatively small home range and can apparently take advantage of small stands of conifers that occur as natural successional stages throughout much of North America. Conversely, several species have comparatively small ranges, including the Spotted Owl, Flammulated Owl and Western Screech Owl, all occurring in western North America. Of these, the Spotted Owl apparently requires large tracts of relatively undisturbed woodland or forest while the Flammulated Owl occurs mainly in montane deciduous woodland.

Literature Synopsis

The literature on northern forest owls includes a minimum of 3800 references which comprises approximately 38% of our accumulated references on owls. These represent studies and reports from virtually every Eurasian and North American country. Geographically, approximately 52% of these references are from North American sources and 48% from Eurasian, principally European sources.

Table 1.--Distribution, status and habitat of Northern Forest Owls.

SPECIES	DISTRIBUTION	AREA(km ²)	HABITAT / STATUS
Flammulated Owl (<u>Otus flammeolus</u>)	North America: sw Canada, w US, s to Guatemala.	2,043,267	Montane conifer forests.
Eastern Screech-Owl (<u>Otus asio</u>)	E N. America: s Canada to Fla. and Gulf Coast, w to c Texas and the front range of the Rocky Mts.	5,408,650	Deciduous woodland, riparian wood, orchards, urban open space / most common bird of prey in sub-urban and urban open space.
Western Screech-Owl (<u>Otus kennicotti</u>)	W N. America: sc Alaska to highlands of c Mexico, e to Rocky Mts., Rio Grande.	3,846,150	Riparian and Oak woodland, cactus desert / earlier treated as Eastern Screech-Owl subspecies; NOT REPORTED ON AT THIS SYMPOSIUM!
Common Scops-Owl (<u>Otus scops</u>)	C and s Eurasia, Asia Minor, nw Africa, s of Sahara except Congo basin.	21,394,209	Widespread, deciduous and coniferous woodland, riverine wood, thornbush, parks, gardens, savanna: NOT REPORTED ON AT THIS SYMPOSIUM!
Striated Scops-Owl (<u>Otus brucei</u>)	C and se coastal Arabian peninsula.	3,822,112	Sometimes grouped as a subspecies of Common Scops-Owl; NOT REPORTED ON AT THIS SYMPOSIUM!
Oriental Scops-Owl (<u>Otus sunia</u>)	S Asia, India, se Asia, n to ne Russia, China, Korea and Japan.	12,019,219	Sometimes grouped as a subspecies of Common Scops-Owl; NOT REPORTED ON AT THIS SYMPOSIUM!
Collared Scops-Owl (<u>Otus bakkamoena</u>)	E Asia, from India, se Asia China, n into Korea and along coast, Indonesia, Philippines, Japan.	13,103,317	Woodland, savanna, parks and gardens: apparently common especially in cultivated areas; NOT REPORTED ON AT THIS SYMPOSIUM!
European Eagle Owl (<u>Bubo bubo</u>)	Eurasia, including India, China, n to tundra, Iberian Peninsula and n Africa, into Asia Minor.	47,475,915	Widespread, temperate and tropical forests, cliffs, outcrops in the desert, cultivated areas / Suffers from local extirpation, reintroduction programs are counteracting some of this.
Great Horned Owl (<u>Bubo virginianus</u>)	North America s of tundra, Central America and South America to Straits of Magellan.	33,533,620	Widespread, forests, deserts, mountain forests, rain forests to limits of woodland, mangrove / Similar to European Eagle Owl it is sometimes persecuted by man because of its "competition".
Blakiston's Fish Owl (<u>Ketupa blakistoni</u>)	Northeast China, Korea, e Siberia.	4,447,030	Coastal areas, riparian woods / Rare and little known species; NOT REPORTED ON AT THIS SYMPOSIUM!
Northern Hawk-Owl (<u>Surnia ulula</u>)	Holarctic: North America from n US into Alaska, Canada, Eurasia, Scandinavia, n Russia.	36,177,848	Clearings and patchy areas of northern conifer forest, low scrubs and trees near water.
Northern Pygmy-Owl (<u>Glaucidium gnoma</u>)	Nw North America, w Canada, w US, s into Mexico and Central America.	4,470,913	Montane Pine-Oak wood, mature conifer and mixed woodland.
Eurasian Pygmy-Owl (<u>Glaucidium passerinum</u>)	Central Europe e to extreme e coast of Russia, southern Scandinavia and Finland.	9,191,846	Conifer and mixed woodland.
Oriental Hawk Owl (<u>Ninox scutulata</u>)	Asia: India, China, se Asia, Japan, Indonesia, Philippines.	13,210,808	Widespread in forests and cultivated areas, mangroves; NOT REPORTED ON AT THIS SYMPOSIUM!
Barred Owl (<u>Strix varia</u>)	North America, s Canada, e US, s to Gulf Coast, s into Mexico and Central America.	7,922,466	Dense deciduous or coniferous woods, near lakes, streams, swamps / has been extending its range w in North America.

Table 1. (continued)--Distribution, status and habitat of Northern Forest Owls.

SPECIES	DISTRIBUTION	AREA(km ²)	HABITAT / STATUS
Spotted Owl (<u>Strix occidentalis</u>)	North America, sw Canada, w US, s into highlands of Mexico.	2,740,938	Dense conifer forest and wooded ravines and canyons / Endangered list because of widespread forest destruction within its range.
Great Gray Owl (<u>Strix nebulosa</u>)	Circumboreal: North America, n US, Canada s of tundra.	29,927,855	Northern coniferous forest.
Tawny Owl (<u>Strix aluco</u>)	Palaearctic: Europe into Asia Minor and c Russia, Himalayas se Asia, Korea and Japan.	20,793,248	Deciduous woodland, cultivated areas, urban open space / Hume's Owl considered by some to be a subspecies of the Tawny Owl is endangered.
Ural Owl (<u>Strix uralensis</u>)	Eurasia: s Scandinavia, ne Europe, c Russia, Siberia, Korea and Japan.	20,802,457	Mixed and coniferous forest.
Long-eared Owl (<u>Asio otus</u>)	Holarctic: North America from n US to n Canada; Europe and c Asia, e to Japan. Nw Africa.	48,066,990	Coniferous and mixed deciduous forest, cultivated areas with trees.
Boreal or Tengmalm's Owl (<u>Aegolius funereus</u>)	Circumboreal in coniferous forests of North America and Eurasia; n to Tundra, s to deciduous forest-prairie ecotone.	38,822,077	Circumboreal coniferous forest also mixed forest of pine, birch and poplar.
Northern Saw-whet Owl (<u>Aegolius acadicus</u>)	North America: southern Canada, US s into Mexican highlands.	10,516,816	Dense woodland, cedar and tamarack swamps.

Note: All of the tabled species were designated appropriate subject species for this symposium. Nearly all of those species bearing the status comment "NOT REPORTED ON AT THIS SYMPOSIUM!" (with the possible exception of the Common Scops-Owl) should be considered SPECIES OF SPECIAL CONCERN for researchers.

This, however, may illustrate the difficulty of obtaining European references rather than a slight imbalance in work on Strigiformes. In North America the majority of literature is from the United States with lesser amounts from Canada, Mexico and Central American countries. In Europe, most published owl work originates from Germany and England, although collectively the Scandinavian countries have contributed a number of very important reports of investigations.

Looking at the various aspects reported in the literature for all species [Figure 1] we can see some general trends, e.g., ecology, distribution and behavior were the predominant aspects reported on for nearly all species. In examining the pie graphs for the individual species, those three categories generally make up at least 75% of the literature aspects. This is, perhaps, a result of the way in which the aspects were defined, e.g., ecology tends to be an encompassing term and while we tried to use that designation only when ecology was emphasized, studies involving a species

interaction with another species, or the environment of the species also had to be categorized as "ecological." The designation "distribution" was used when specific geographic locale(s) for a species was/were given and our rule of thumb in using this designation was--was enough information given that the article "plotted a point or points" where the species was found? Behavioral information is provided whenever living individual(s) of the species were discussed. The remaining categories of aspect, thus, remain areas where more research is needed, i.e., conservation, taxonomy, physiology and anatomy.

In terms of the absolute number of references, the Great Horned Owl and Eagle Owl have been the topic of the greatest number of papers, followed by the Long-eared Owl. Conversely, several species such as Blakiston's Fish Owl, Collared Scops Owl, Oriental Scops Owl and Oriental Hawk Owl have been investigated less, and are known mostly from anecdotal and range accounts published in field guides and publications exemplified by Dement'ev's

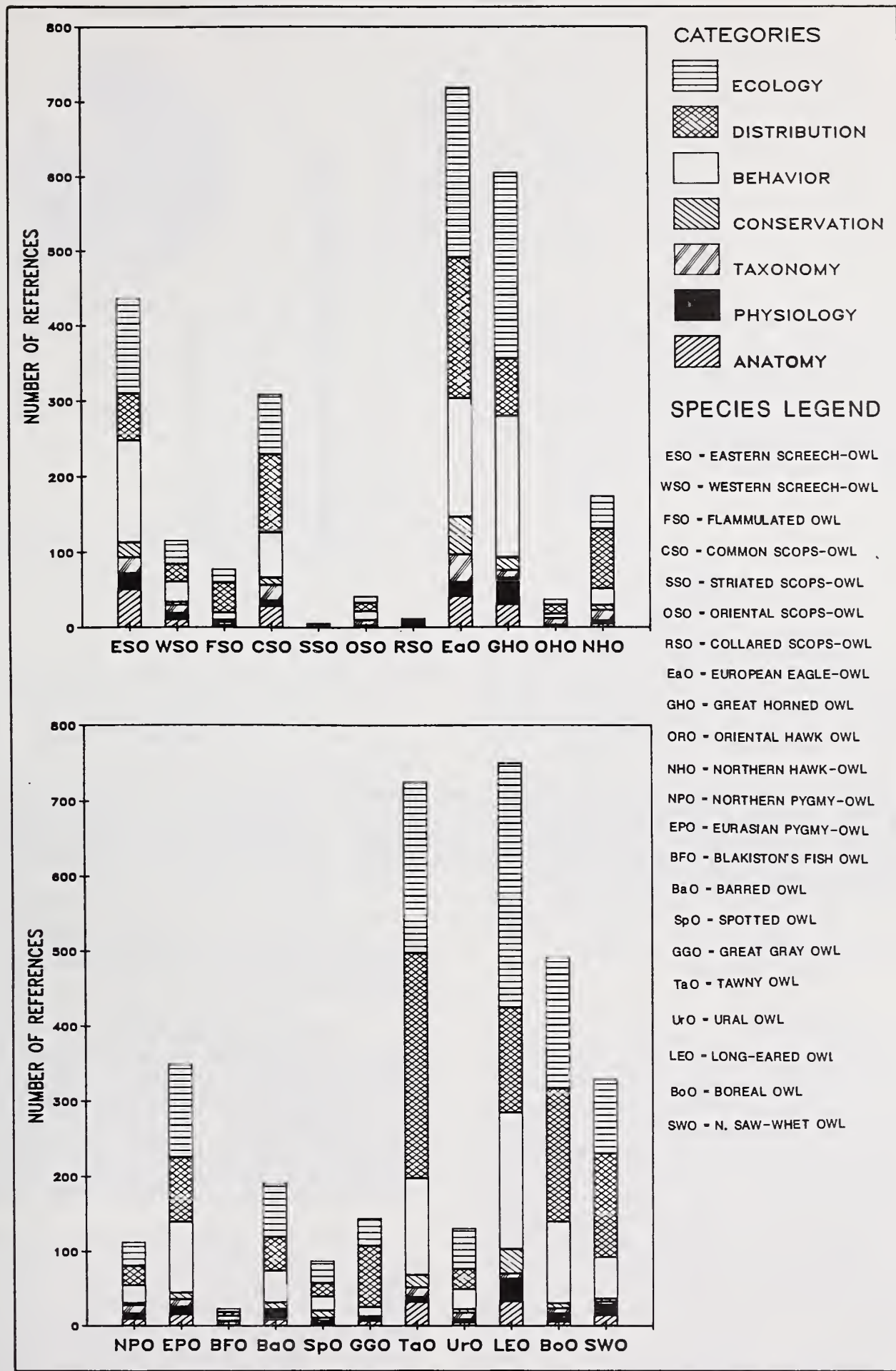

Figure 1.--Summary of literature on owls of the "Northern Forest" by species and informational category. Species legend covers all 22 species designated for this symposium. Articles were identified from the 6,590 cited in Clark, Smith and Kelso (1978). In nearly all species the information content of articles is at least 75 - 80% ecology, distribution and behavior.

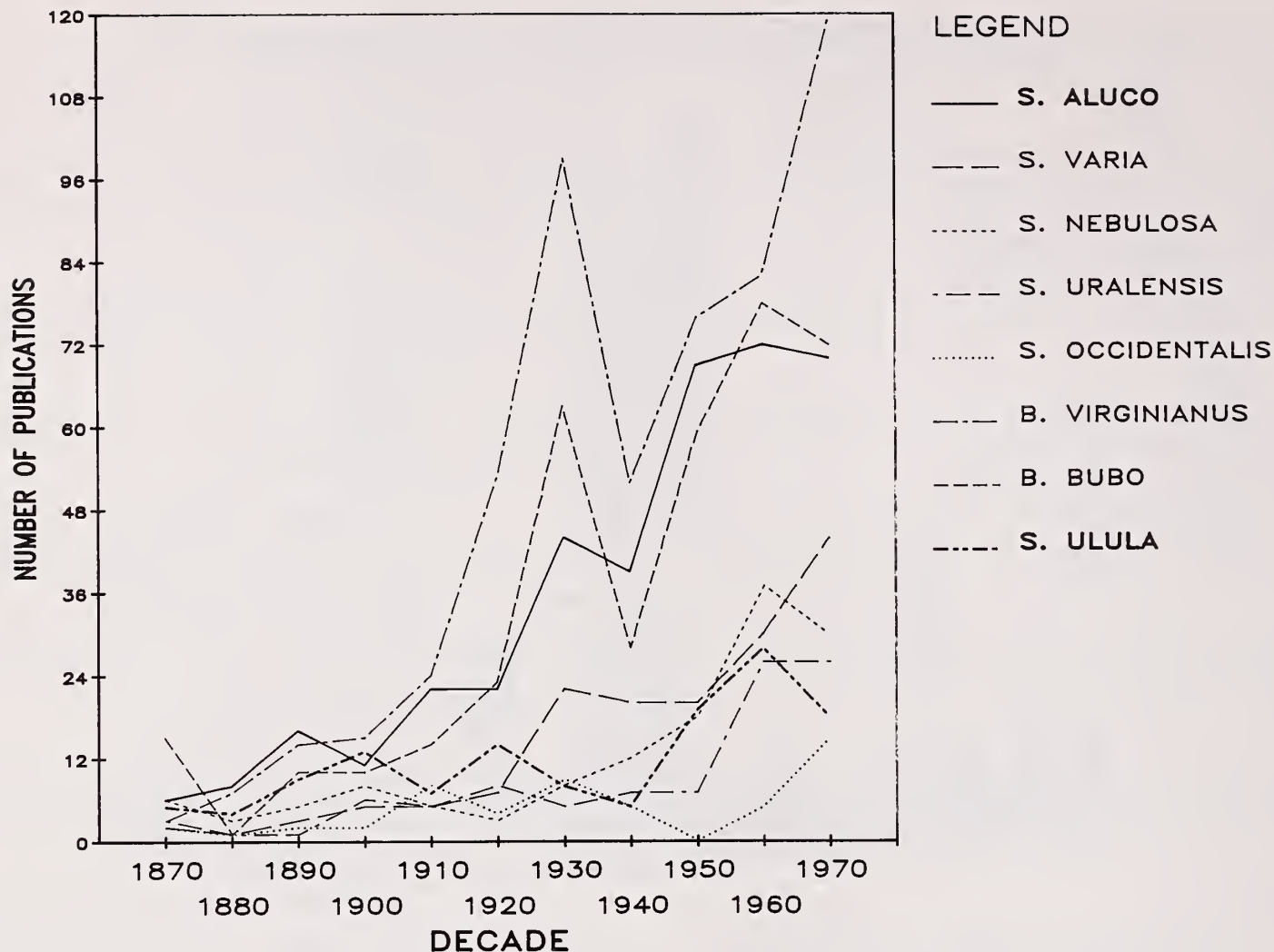

Figure 2.--A century of literature on eight owl species reveals 1) a general upward trend for nearly all species with a "burst" of articles in the 1930's, a decline in the WWII years and then a resurgence beginning in the 1950's and 2) a dichotomy with a few species being relatively well studied and a larger number only recently becoming subject for considerable study.

"Birds of the Soviet Union" and similar works.

Chronology

While the references date from 1842 most of the literature has come within the last 50 years, i.e., from 1930 to the present. We did not plot the chronology for all species (see Fig. 2) due to the lack of space but rather selected a cross-section of species. The same general trend was observed in all species. Much of the early literature is imbedded within general works, e.g., faunal treatments, thus making it difficult to locate and to cite.

Genera and Species Discussion

Strix Species

Northern forest owls include five species of *Strix* for which we have located a total of 873 publications (see Fig 3). Of these, 46.8% concern the Tawny Owl (*Strix aluco*), 17.4% the Great Gray Owl (*Strix*

nebulosa), 16.8% the Barred Owl (*Strix varia*) and 7.1% the Spotted Owl (*Strix occidentalis*).

Excepting the Tawny Owl, the most common category of topic coverage is ecology, which averages about 32% for each of the *Strix* species and 30% for the Tawny Owl literature. Distribution is the most common topic of papers on both the Great Gray Owl (50.7% of topics) and the Tawny Owl (39.7% of topics), followed by ecology.

For all five species the least frequent topics were physiology, anatomy, conservation and taxonomy. About 10% of papers on the Spotted Owl were concerned with aspects of its conservation, reflecting in main the limited knowledge of the status of this *Strix* species and loss of its forest habitat in the western United States.

The Great Gray Owl is the only circum-boreal *Strix* species. The North American literature on this species originates from 18 states and five Canadian provinces, and in Eurasia from eight countries. Most of the literature on this species is from North

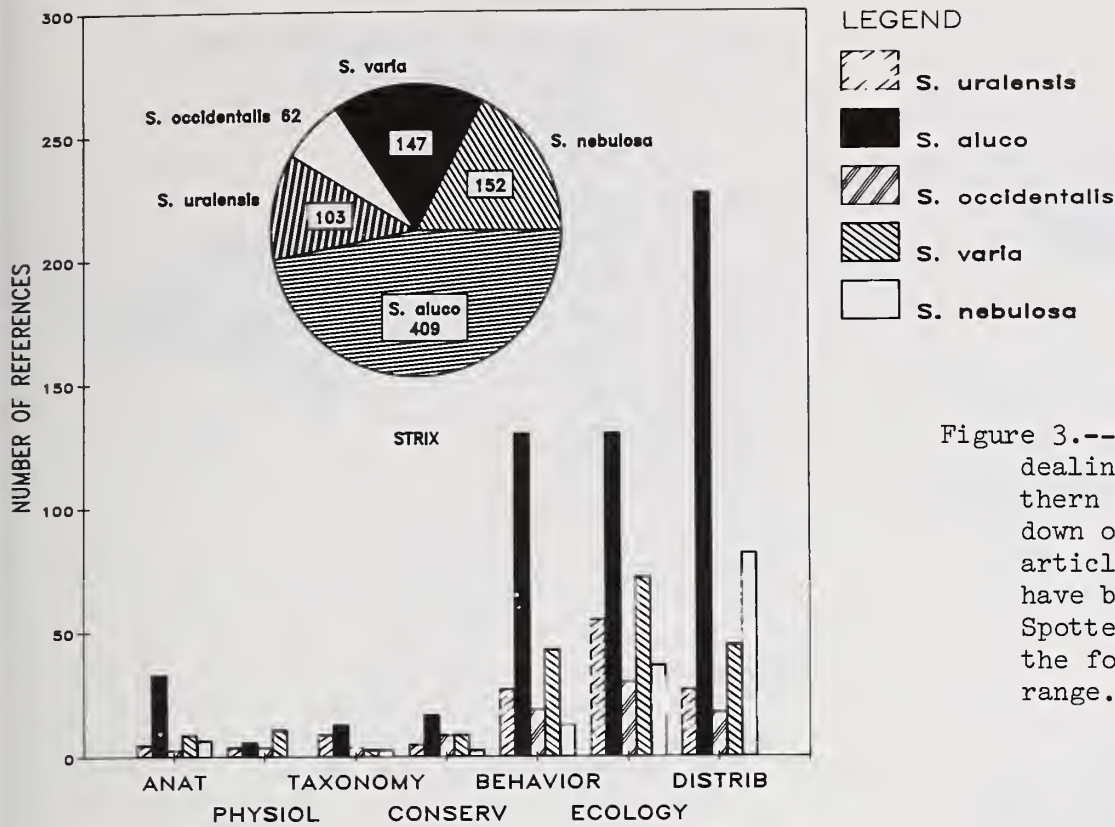

Figure 3.--Summary of the total number of articles dealing with the five *Strix* species of northern forest owls (pie chart) and a breakdown of the informational content of those articles (legend). Although more articles have been written about the Ural Owl than the Spotted Owl, this fact is misleading in that the former has a much greater distributional range.

America (72.4% of published papers) and of this, 42.6% originates from the United States, mostly from Minnesota and Massachusetts. Three European countries, Finland, Sweden and Germany have contributed

the bulk of the European literature. Literature of the Tawny Owl originates from 15 European and three Asian countries. Of these, the great majority are from Germany, which has the astounding total of 142 (34.7%) of Tawny Owl papers, and England, 121 (29.6%). Ural Owl papers originate from 12 European countries and two Asian countries. Most are from Germany (19.4%), Finland (17.3%) and Sweden (15.4%) in Europe while 6.8% are from Japan in Asia. Barred Owl literature is from four Canadian provinces, 28 states and the District of Columbia, while the literature on the Spotted Owl has a much more restricted distribution, originating only from four western states, with 33.9% from California and 19.4% from Oregon.

Aegolius, Asio and Bubo species

We have selected summary diagrams for five species of the above three Genera, after much deliberation over which of the many diagrams were most instructive, based on the following criterion: 1) the Aegolius species were selected because they are small and one [acadicus] is found only in the New World while the other is found in both the Old and New World, thus giving some information that might serve as a basis for comparison of the amount of research that

has been done between the Hemispheres, [see Fig. 4]; 2) Asio was selected as a medium-sized owl that is widely distributed throughout the world, thus giving us some clues as to where in the world it has been most studied and where further work is generally needed [see Fig. 5]; and 3) Bubo was selected because there are two large species, one confined to the Old World and the other the New World so that comparisons similar to the above might be made [see Fig. 6].

CONCLUSIONS

The owls of the northern forest, 22 species in number, make up about 16% of the known species of owls of the world. The literature that we have identified as dealing with these species includes about 3800 articles or about 43% of the literature that we know of. There is, of course, more as yet unidentified. We do feel, however, that we can draw some conclusions from this large sampling, e.g., seven species out of the 22 designated for this symposium were not reported on here. Of those seven species, the literature for five species totals only 72 articles or about 0.7% of all of the literature. Those five species; the Striated Scops-Owl (Otus brucei) [5], the Oriental Scops-Owl (Otus sunia) [29], the Collared Scops-Owl (Otus bakkamoena) [9], Blakiston's Fish Owl (Ketupa blakistoni) [11] and the Oriental Hawk Owl (Ninox scutulata) [18] thus show up as species for which there is a severe shortage of information!

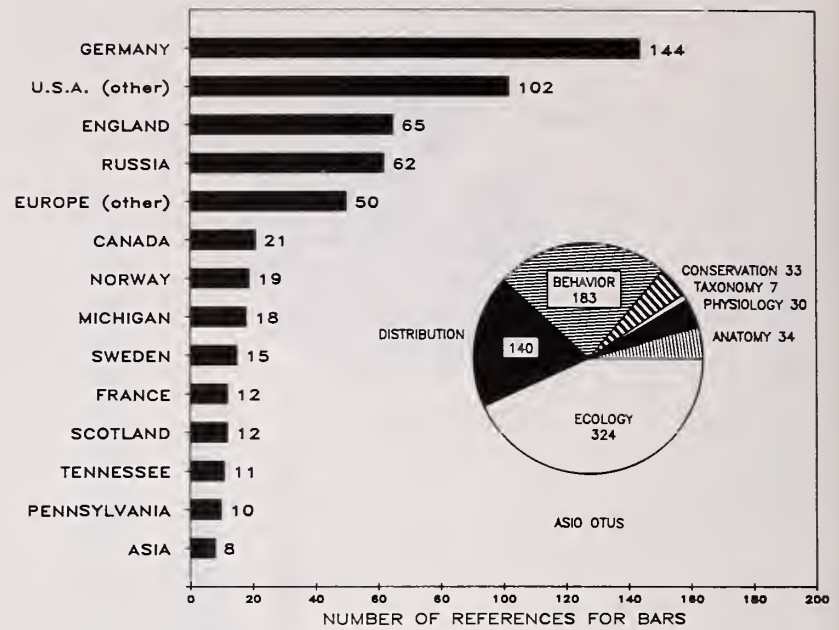
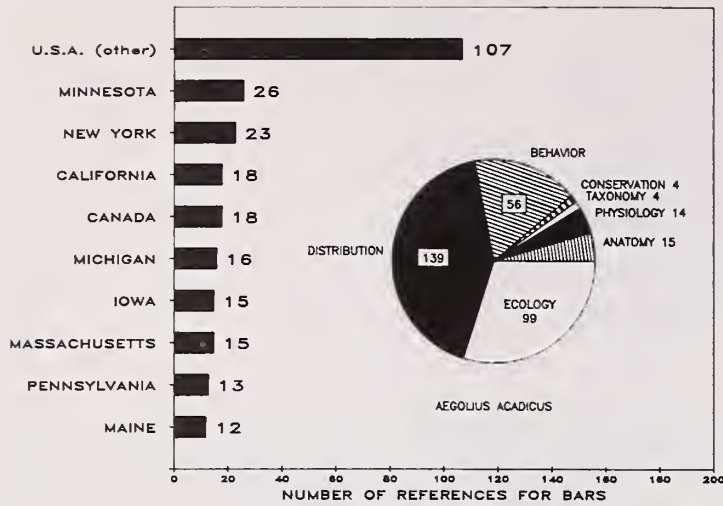

Figure 5.--The trend in the literature of the most widely distributed northern forest owl, the medium-sized Long-eared Owl, is quite similar to that of the smaller owls.

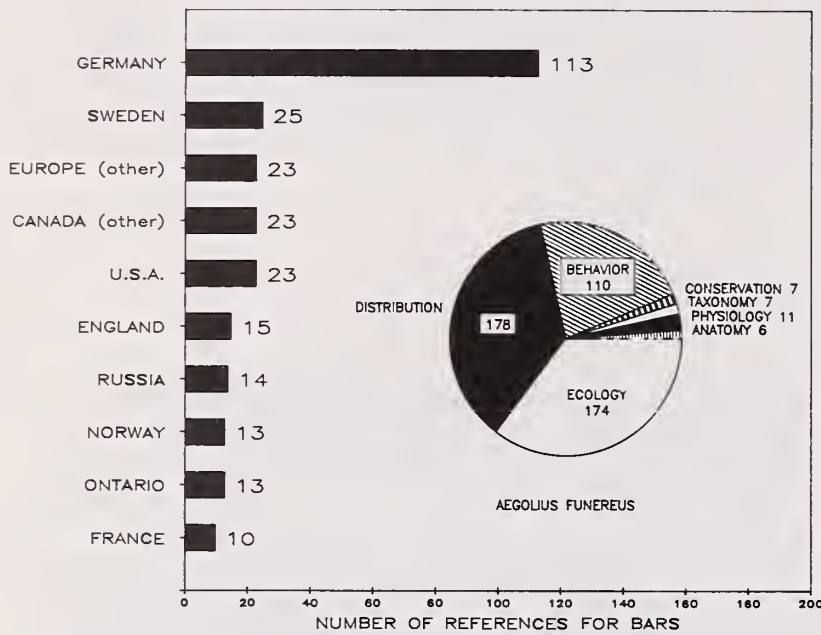
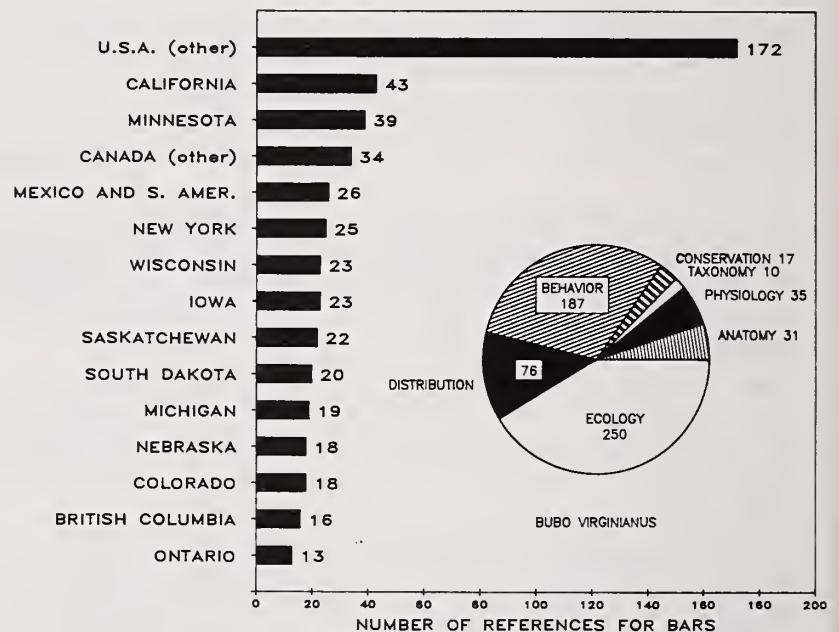

Figure 4.--Comparison of informational content, extent of study, and geographic distribution of the literature on Northern Saw-Whet (upper) and Boreal or Tengmalm's Owl. The former is confined to North America, while the latter is also found in northern Europe also. Note the same three informational categories predominate.



When the National Wildlife Federation was preparing the final copy for our bibliography we asked them to use the Spotted Owl (*Strix occidentalis*) as a model for the artwork for the cover. We did this because we saw that as a species badly in need of research. Since publication of the bibliography in 1978 there has been considerable research done on that species and some of that need for research has been met. We are sure that much of the interest for that species has arisen from its

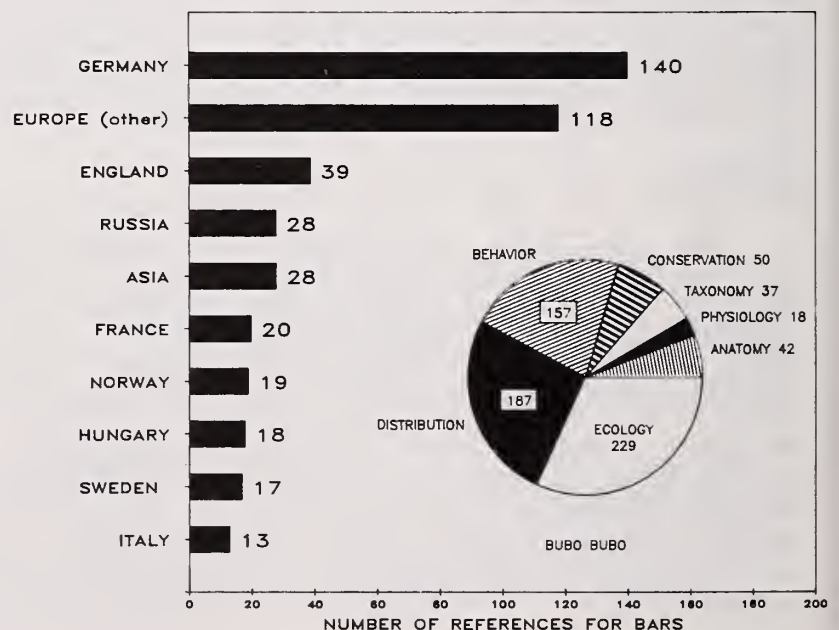

Figure 6.--Comparison of the large Great Horned Owl (upper) and its ecological counterpart the Eurasian Eagle Owl (lower) shows the same three informational categories prevail as for the other species compared.

designation as an Endangered Species. We are here designating the above five species, i.e., the Striated Scops-Owl, the Oriental Scops-Owl, the Collared Scops-Owl, Blakiston's Fish Owl and the Oriental Hawk Owl as SPECIES OF SPECIAL CONCERN for researchers in order to call attention to the urgent need for information on those species. The urgency arises from the alarming rate at which habitats for wildlife are being destroyed. While we have identified the need for information for certain species we have also identified a need for communication with regard to information that currently exists in the literature. Much of the literature is not readily available to the conservationists and wildlife and land managers who have a need for the available literature. There are computerized databases available that can get a person with the need to know into some of the literature but they do not approach completeness in their coverage and fairly extensive search strategies are sometimes required to access the literature. Bibliographies are extremely difficult to obtain funding for as most of the conventional sources of funding are not available for such publications. They are reference works with perhaps a select "clientele," but they are critically needed. Governmental agencies or wildlife conservation organizations would do the owls [as well as other wildlife forms] a great

service if they would actively seek working bibliographies and support their preparation and publication. Authors, utilizing bibliographies, can also further the cause by citing bibliographies in their research publications.

LITERATURE CITED

- Burton, J.A. [Ed.] 1973. Owls of the world. New York, E.P. Dutton and Co., Inc. 216 pp.
- Clark, R.J., D.G. Smith and L.H. Kelso. 1978. Working bibliography of owls of the world: With summaries of current taxonomy and distributional status. NWF Sci./Tech. Series No. 1. 319 pp.
- Dement'ev, G.P., N.A. Gladkov, E.S. Ptushenko, E.P. Spangenberg and A.M. Sudilovskaya. 1966. Birds of the Soviet Union. Vol. 1. Jerusalem, Israel Prog. Sci. Trans. 704 pp.
- Grossman, M.L. and J. Hamlet. 1964. Birds of prey of the world. London, Cassell and Co. 496 pp.
- Mikkola, H. 1983. Owls of Europe. Vermillion, Buteo Books. 397 pp.

Nearly Synchronous Cycles of the Great Horned Owl and Snowshoe Hare in Saskatchewan¹

C. Stuart Houston²

Abstract.--In the aspen parkland of Saskatchewan, Great Horned Owl reproductive success is cyclical and appears to follow closely the numbers of the Snowshoe Hare, its main prey item. In peak years, nearly all owls nest, some raise four young, and they fledge an average of 2.5 young per successful nest.

INTRODUCTION

A 30-year study of Great Horned Owl productivity included banding of 4285 nestlings in 1883 successful nests. Changes in numbers and reproductive success were roughly coincident with the 10-year cycle of the Snowshoe Hare, (Lepus americanus), though as with the lynx, the owl may sometimes peak a year after the hare.

The 10-year cycle of the Snowshoe Hare has been documented for over 100 years. The famous explorer, mapmaker and fur trader, Peter Fidler, gave the following report from Dauphin House, Manitoba, in 1820: "There are in some seasons plenty of rabbits, this year in particular, some years very few, and what is rather remarkable, the rabbits are the most numerous when the cats [lynx] appear. . . . the cats are only plentiful at certain periods of about every 8 or 10 years, and seldom remain in these southern parts in any number for more than two or three years."

Similarly, Dr. John Richardson, surgeon and naturalist with the first and second Franklin expeditions in the 1820s, wrote: "the Canada lynx is the animal which perhaps most exclusively feeds upon it [the hare]. It has been remarked that lynxes are numerous only where there are plenty of hares in the neighbourhood. At some periods a sort of epidemic has destroyed vast numbers of hares in particular districts, and they have not recruited again until after the lapse of several years, during which the lynxes are likewise scarce."

Lloyd B. Keith's well-researched book, Wildlife's Ten-year Cycle, includes many graphs from Hudson's Bay Company pelt collections and other sources. These demonstrate the approximate 10-year cycle of the hare and lynx as well as the one or two year lag in peaks and troughs between different geographic regions. The Ruffed Grouse cycle was almost synchronous with the hare's, but at that time data were inadequate for the Great Horned Owl. Later, long-term studies by Keith and associates in the mixed forest at Rochester, Alberta, provided evidence that Great Horned Owl numbers and reproductive success were quite clearly synchronous with Snowshoe Hare numbers (Rusch et al 1972).

METHODS

A relatively small number of observant, helpful farmers and rural schoolteachers have provided fairly consistent effort in finding nests each year. However, I exhorted them to extra searching in the low-hare years of 1984 and 1985, since nest sample numbers had been very low during the previous bottoms of the cycle in the 1960s and 1970s. With extremely few exceptions, every active nest reported within a wide study area was visited and the young banded.

Skewing of Nest Numbers

The nest total was skewed upwards in two years. In 1967, two assistant tree climbers, Doug Whitfield and Jon Gerrard, made a special effort and found over 30 nests themselves. In 1968, Whitfield found ten nests and this one year we also went further southeast to 21 nests near Indian Head and Lemberg, an area later covered by Lorne Scott of Indian Head. Total young banded in these two years was thus disproportionately high. Nest success was skewed downwards in 1982 when a forest tent caterpillar invasion almost filled the aspen forest with thick webs, apparently impeding hunting by the parent owls.

¹Paper presented at the symposium, Biology and Conservation of Northern Forest Owls, Feb. 3-7, 1987, Winnipeg, Manitoba. USDA Forest Service General Technical Report RM-142.

²Stuart Houston is Professor of Medical Imaging, University of Saskatchewan, Saskatoon, Sask.

RESULTS

10-YEAR CYCLE of GHO vs. PEAKS in SNOWSHOE HARE

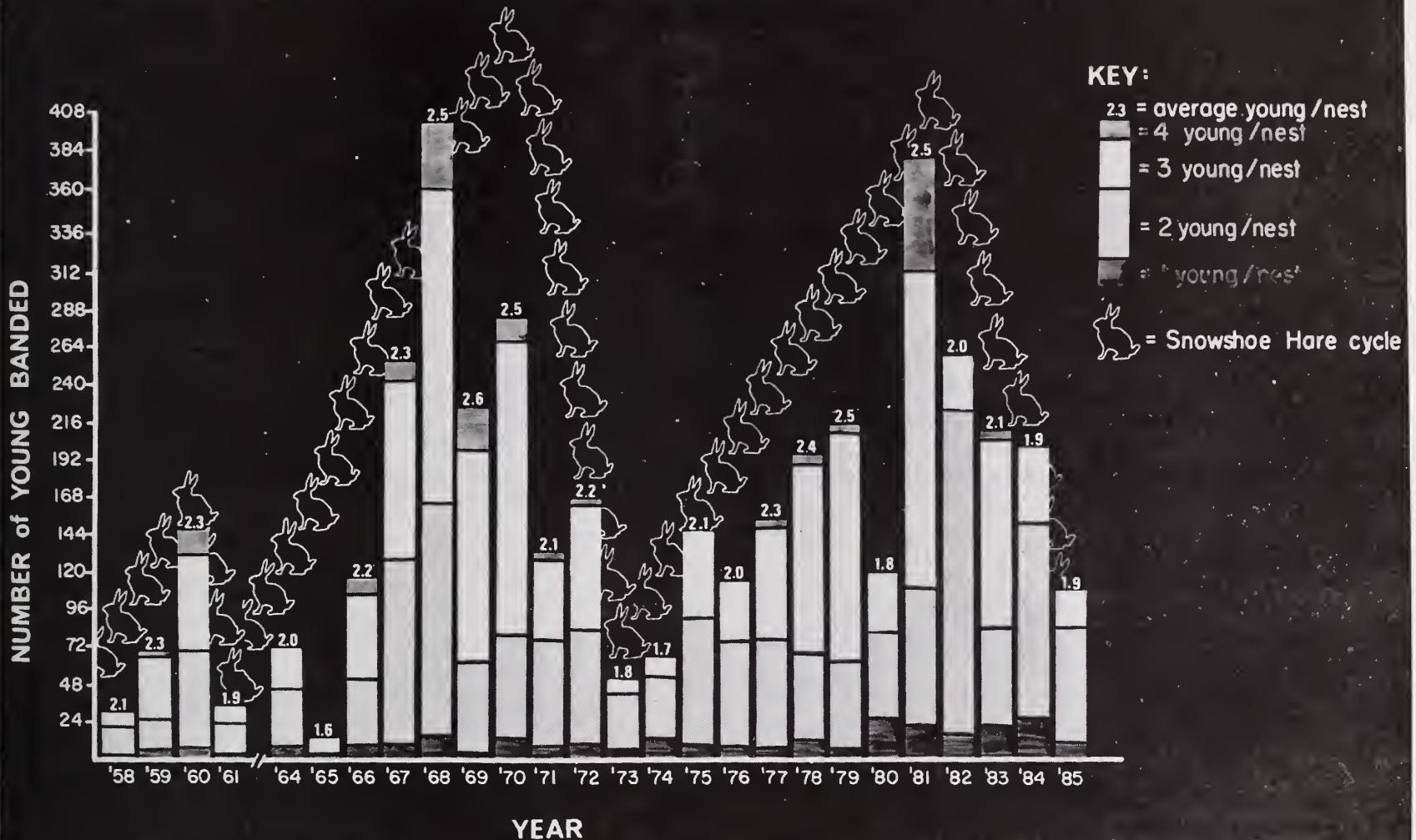

Comparable Hare, Lynx and Goshawk numbers

Hares were monitored numerically at Rochester, Alberta, from 1964 through 1976, but similar numbers are not to my knowledge available for any Saskatchewan locality. The numbers of lynx trapped each year between 1920 and 1984, an indirect indication of hare numbers, have been published for Alberta and show peaks varying from 8 to 11 years apart, averaging 9.6 years (Todd 1985). Owls peaked in Saskatchewan in 1981. The lynx "crash" occurred in Alberta in early 1982. Goshawks, responding to the hare crash, left the forest and appeared in peak numbers in Duluth, Minnesota in 1972 and 1982 (R.F. Green, pers. comm.)

RESULTS

At the peak of the 10-year cycle of the Snowshoe Hare, nearly 100% of Great Horned Owls breed, with up to one pair for each 5 km² of aspen parkland habitat. They produce an average of 2.5 young per successful nest; only in the years at the top of the cycle are nests with three young in the majority, while some pairs fledge four young (fig. 1). At such times, Snowshoe Hares are extremely numerous. Some owls use nest

sites in more conspicuous locations near roads, that weren't utilized in the years when demand was less. Nests are easier to find.

When Snowshoe Hare numbers crash, most Great Horned Owls move away, some into grassland habitat where production is sustained at a lower level by the less cyclic White-tailed Jack Rabbit (*Lepus townsendii*). Others travel southeast to winter as far away as Nebraska and Iowa (Houston 1978; Houston mss.). For those owls remaining there is insufficient food in late winter. Less than half of the remaining owls attempt to breed, producing as few as 1.6 nestlings per successful nest. Nests with one and two young predominate, nests with three young are less common, and nests with four young simply do not occur. My food remains data indicate that the Snowshoe Hare is, in terms of biomass, the main food item found in Great Horned Owl nests in Saskatchewan in May (C.S. Houston and H.C. Smith, mss.). Even at the bottom of the hare cycle when we see no hares at all, the owls somehow find an occasional hare and bring it as food to their nest.

Figure 1 in fact minimizes the effects of Snowshoe Hare numbers on Great Horned Owl success,

since much of our overall Saskatchewan banding area contains both Jack Rabbits and Snowshoe Hares. The best Snowshoe Hare habitat within the aspen forest at Birch Hills - Crystal Springs - Yellow Creek - Cudworth - Humboldt - Wadena was therefore contrasted with a more southerly rectangle which includes Simpson - Raymore - Kelliher - Duval - Strasbourg - Bulyea. Because the northern area has so few nests at the bottom of the cycle, the long-term average number of successful nests there is only 19, as compared with the average of 30 further south. In a peak owl year of 1981, when hares were visible everywhere, the northern area had 42 successful nests -- which fledged 102 young owls. In 1985, when hares were nowhere to be seen, the last of two known incubating female owls was still on her nest on 9 May but had deserted by the time of our fruitless visit on 19 May.

In contrast, the southern area in the peak year of 1981 also had 42 successful nests -- which fledged 118 young. In 1985, at the Snowshoe Hare low, these owls had dropped to half their previous numbers and were apparently relying on Jack Rabbits, for there were 20 successful pairs able to fledge 37 young.

Finally, there was a highly significant correlation ($r=.61$, $p < .01$) between the number of nests found and the average number of young produced per successful nest. This offers further support for my conviction that cyclical variations

are real and not merely artefacts, for example, of observer effort.

DISCUSSION

Although the Great Horned Owl is a strong and capable hunter, food is very much restricted due to cold weather and deep snow during courtship in February and during incubation in March. In the aspen parkland of Saskatchewan, this owl's reproductive success depends heavily on its main prey species, the Snowshoe Hare. As a result, their cycles are closely synchronous.

LITERATURE CITED

- Houston, C.S. 1978. Recoveries of Saskatchewan-banded Great Horned Owls. *Canadian Field-Naturalist* 92(1):61-66.
- Keith, L.B. 1963. *Wildlife's ten-year cycle*. 201 p. University of Wisconsin Press, Madison.
- Richardson, J. 1828. *Fauna Boreali-Americana, or the Zoology of the Northern Parts of British America*. Part first: the Mammals. 302 p. John Murray, London.
- Rusch, D.H., E.C. Meslow, P.D. Doerr, and L.B. Keith. 1972. Response of Great Horned Owl populations to changing prey densities. *Journal of Wildlife Management* 36(2):282-296.
- Todd, A.W. The Canada Lynx: ecology and management. *Canadian Trapper* 13(2):15-20.

Reversed Size Dimorphism in 10 Species of Northern Owls¹

W. Bruce McGillivray²

Abstract.--Nineteen measurements were taken on museum specimens of 8 species of northern forest owls as well as two other common northern owls. Dimorphism indices were computed for all characters and combined with life-history data in a principal component analysis. Overall levels of SSD vary from 2.5% (Northern Hawk-Owl) to 8.0% (Boreal Owl). There are no relationships between SSD and migratory habitat, size, and higher order taxonomy of the species. Dimorphism levels are lowest for skull characters and highest for body core measures. For many characters, sexual size dimorphism is correlated with the percentage weight difference between males and females.

INTRODUCTION

Reversed size dimorphism (RSD) is said to occur if the female of a species is larger than the male. This situation obtains for most, but by no means for all, species of raptorial birds (Falconiformes, Strigiformes and Stercorariidae). These taxa are not closely related, therefore a unitary explanation for the evolution of RSD has not been possible. A wide variety of hypotheses have been proposed to explain RSD in diurnal raptors (see Mueller and Meyer 1985 for a recent review and references) although the relevance of many of these hypotheses for owls is debatable (Mueller 1986). Only Earhart and Johnson (1970) and Mueller (1986) have specifically examined the question of RSD in the Strigiformes (see also Snyder and Wiley 1976).

I showed for Great Horned Owls (*Bubo virginianus*) that the standard measures of size (weight and wing length) used in previous RSD studies are not highly correlated with multivariate estimates of size obtained from skeletal characters (McGillivray 1985). As well, the degree of RSD varied from -2.18% to 9.75% among the 16 skeletal characters. A

¹Paper presented at the symposium, Biology and Conservation of Northern Forest Owls, Feb. 3-7, 1987, Winnipeg, Manitoba. USDA Forest Service General Technical Report RM-142.

²W. Bruce McGillivray, Curator of Ornithology, Provincial Museum of Alberta, Edmonton, Alberta.

legitimate question is: which characters should be selected to give the best measure of the difference in size between males and females?

There are several assumptions with respect to size that are implicit in discussions of the evolution of RSD:

(1) Variable x (or y) is a good measure of size. It is assumed that we can measure some characters (e.g., wing length or weight) and using them to determine quantitative differences between males and females; relate these numbers to interactions between members of pairs which led to the evolution of RSD. The problem is as noted above - the choice of characters may affect the assessment of size variation. It is not easy to define size univariately since intercharacter correlations may be low. Consider the Great Gray Owl (*Strix nebulosa*), by wing length it is the largest North American owl but by weight it ranks a distant third behind the Snowy (*Nyctea scandiaca*) and Great Horned Owls (Earhart and Johnson 1970). Is the Great Gray therefore a large or a medium-sized owl?

(2) Correlations derived from interspecific comparisons are valid for intraspecific relationships. Figure 1 shows 2 variables, which are highly positively correlated if examined across a range of species but within each species they may be uncorrelated or even negatively correlated. These types of interspecies correlations lead to the concept that any of several characters is adequate for estimating size.

Table 1.--Storer's index of dimorphism¹ for 17 skeletal characters of 10 species of owls. Sample sizes are in parentheses (no. of males/no. of females).

Variable ²	Nyctea scandiaca (16/22)	Bubo virginianus (53/79)	Strix nebulosa (25/49)	Strix varia (8/7)	Asio flammeus (51/32)	Asio otus (11/4)	Aegolius funereus (8/1)	Aegolius acadicus (8/9)	Surnia ulula (1/3)	Glaucidium gnoma (2/1)
skull	4.5	3.3	3.6	1.8	1.6	1.0	4.1	3.8	4.1	- 5.8
skull wid.	1.7	-2.2	3.2	0.5	1.4	-0.36	7.5	1.1	1.8	5.2
intorb. wid.	7.1	4.5	1.7	-1.3	0.9	1.2	3.5	1.1	-2.7	-15.6
mandible	5.2	4.4	2.8	1.2	2.5	1.4	5.3	2.2	5.3	- 6.3
coracoid	7.8	6.4	7.4	3.7	4.0	3.2	7.5	4.9	-1.9	2.4
sternum	6.8	5.6	7.6	2.0	4.2	3.5	9.2	2.2	1.8	2.9
Keel	5.5	5.4	8.3	-0.2	4.4	2.2	9.3	1.6	1.9	- 1.3
Sternum wid.	9.5	3.7	4.6	4.6	5.5	3.2	5.3	2.6	6.4	9.0
Humerus	8.3	5.7	6.6	3.1	3.8	3.0	8.5	6.0	1.5	3.8
Ulna	8.0	5.4	6.4	3.4	3.9	3.0	8.0	5.6	0.3	3.6
Carpomet.	7.6	5.4	7.0	4.3	3.3	3.4	9.6	5.6	0.5	6.5
Femur	7.1	4.1	5.7	3.0	3.4	2.7	9.7	4.8	1.1	6.1
Tibiotarsus	6.9	3.8	5.8	4.0	4.5	3.6	12.4	3.8	-1.0	4.8
Tarsomet.	7.1	2.3	5.4	3.6	4.8	2.7	8.7	2.3	-1.1	5.7
Tarsom. wid.	10.7	9.8	10.4	7.8	4.7	4.2	12.8	4.0	7.1	0.7
Synsacrum wid.	11.1	9.7	8.5	3.2	5.4	5.9	11.0	5.2	5.6	7.2
Scapula	10.2	6.5	7.3	3.8	4.8	2.5	11.4	4.3	4.8	3.4

¹ Negative values indicate that males are larger than females

² Variables represent maximum length unless otherwise indicated

(3) A "trait important in the evolution of RSD should be expressed to a greater extent in species with high RSD than in

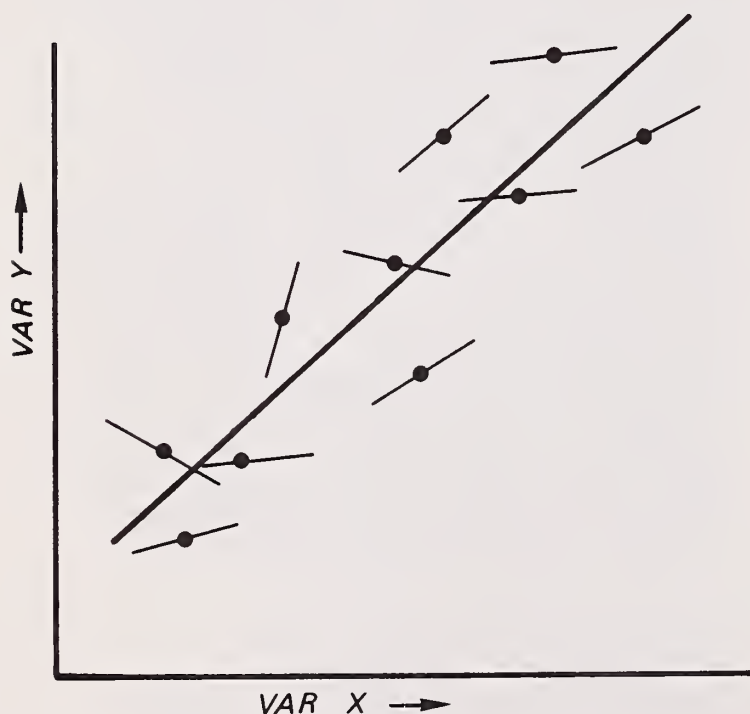

Figure 1.--Hypothetical relationship between x and y demonstrated interspecifically - solid line based on species means and intraspecifically - short lines. Note that the relationship holds interspecifically regardless of the slope demonstrated within each species.

those with low RSD." (Mueller 1986: 404). First, if RSD varies from one character to another, which is the best measure to test the trait against; and secondly, by choosing a particular measure of RSD, we are biasing our analysis in favor of traits which are related to this measure. For instance, if weight is the measure of RSD used, a correlation between intra-pair dominance and RSD in weight may be a strong argument for the significance of female dominance in the evolution of RSD. However, I would argue for example, that the lack of a correlation between diet and RSD for weight does not preclude a role of male/female diet differences in the evolution of RSD for skull or leg characters which may not be correlated with weight. Finally, this assumption precludes modification of the relative size of males and females which occur for reasons unrelated to the initial evolution of sexual size dimorphism (Johnston and Fleischer 1981, Payne 1984, Jehl and Murray 1986).

In this paper I look at RSD for 10 species of owls which occur in Alberta; 8 of these are northern forest owls. RSD is assessed univariately with skeletal characters and multivariately through character complexes. The purpose of the paper is to determine whether patterns for RSD exist both within and among species which can provide insight into the best methodology for estimating size and examining the evolution of RSD in owls.

MATERIALS AND METHODS

Data Collection

Nineteen measurements were taken with dial calipers on skeletons of 10 species of northern owl. Most measures defined a greatest linear dimension such as length or width of an element. A description of the measures (Table 1) can be obtained from Schnell (1970). Note that tarsometatarsus width (in this paper) equals the tarsometatarsus distal end width of Schnell (1970). Because some owl skeletons were prepared with the rhamphotheca removed and others with it attached, skull length and mandible length were defined as composite measures to standardize the data (McGillivray 1985). Hence, skull length equals total skull length minus premaxilla length and mandible length equals total mandible length minus dentary length. Most specimens are from the collection of the Provincial Museum of Alberta and were obtained in Alberta, Canada. However, some Pygmy Owls (*Glaucidium gnoma*) are from the state of Washington, some Hawk Owls (*Surnia ulula*) were obtained in Ontario and some Barred Owls (*Strix varia*) were acquired in several eastern states of the USA. To provide standard measures of weight, I used the values given in Snyder and Wiley (1976).

Data Analysis

RSD for skeletal characters was initially examined univariately using a dimorphism index (DI) of Storer (1966). The index measures the difference between the variable means of each sex (female \bar{X}_f ; male \bar{X}_m) as a percentage of the grand mean [$100 (\bar{X}_f - \bar{X}_m) / (\bar{X}_f + \bar{X}_m) / 2$].

Skeletal characters were grouped into "complexes" to facilitate interpretation of interspecific differences. The size of a complex equals the sum of the size of each variable in the complex. The sum of a group of characters represents a standard size axis (Mosimann 1970, Reyment et al. 1984) and is shown to be analogous to an ideal isometric size vector derived from a principal component analysis (McGillivray 1985, Somers 1986). The four complexes are skull (the sum of skull length, skull width, and mandible length); body (the sum of coracoid length, sternum length, keel length, sternum width, scapula length and synsacrum width); wing (the sum of humerus length, ulna length and carpometacarpus length) and leg (the sum of femur length, tibiotarsus length, tarsometatarsus length and tarsometatarsus width).

Relative trait lengths (Cherry et al. 1982) were calculated for the four character complexes and compared among species. These measures (which equal complex size/total size, where total size is the sum of all the

characters) although not statistically independent of size (Atchley et al. 1976, Somers 1986) provide a convenient method of comparing relative dimensions of characters between sexes of a species and among species for each sex.

Finally, the skeletal data generated in this study were combined with data presented in Mueller's (1986) discussion of reversed size dimorphism in owls in a principal component analysis. This analysis generated components linking diet, weight variation, clutch size and egg weight to RSD as measured by skeletal characters. All statistical analyses were run using the SAS statistical package (SAS Institute 1985) or with a hand calculator.

RESULTS

A summary of univariate measures of RSD for each species is given in Table 1. For all species, there is considerable intercharacter variation in the degree of RSD. It is also apparent that there is great variation among species in the degree of RSD for each character. This variation will be examined in greater detail later but it is worth noting two things here. First, intrageneric species pairs (*Asio*, *Aegolius* and *Strix*) show no greater similarity than intergeneric pairs. Secondly, the amount of RSD exhibited for coracoid, sternum, keel, and carpometacarpus length and tarsometatarsus width is significantly correlated with RSD for weight ($r=0.68, 0.71, 0.71, 0.63$ and 0.71 respectively, $P < .05, n=10$). RSD for humerus length and ulna is correlated at 0.61 and 0.62 respectively with RSD for weight, these are very close to the .05 level of 0.63 .

These data are more easily interpreted if the variables are combined into character complexes (Table 2). Overall, mean levels of RSD are highest for body characters and lowest for head characters (Table 3). There is no relationship between rank size (weight) and RSD for weight (Table 2). As well, all correlations between RSD for weight and RSD for character complexes are not significantly different from 0.0. Two potential sources of pattern in RSD variation are phylogenetic similarity and habitat preferences. However, none of the intrageneric species pairs show particularly similar levels of dimorphism. As well the two open-country and migratory species - *Nyctea scandiaca* and *Asio flammeus* show quite different levels of RSD.

A multivariate examination of RSD was made by including the univariate measures of dimorphism and those obtained from character complexes with variables given in Mueller (1986:392) in a principal component analysis. Variables taken from Mueller (1986) are wing loading, percent mammals, birds and

Table 2.--Dimorphism indices for weight and skeletal character complexes of 10 species of owls. Species are ranked (from left to right) by weight.

	Nyctea scandiaca	Bubo virginianus	Strix nebulosa	Strix varia	Asio flammeus	Asio otus	Aegolius funereus	Aegolius acadicus	Surnia ulula	Glaucidium gnoma
Head	4.1	2.4	3.0	1.1	1.7	0.36	4.9	1.9	2.9	-4.5
Body	8.3	5.7	7.4	2.8	4.7	3.4	8.9	2.9	2.5	5.2
Wing	8.0	5.5	6.6	3.4	3.8	3.5	8.2	5.8	0.8	4.2
Leg	7.2	4.0	5.9	3.8	4.3	3.1	10.8	3.6	-0.5	5.2
Weight	17.8	27.7	32.4	23.6	18.3	13.0	31.4	19.2	14.1	16.4

invertebrates in the diet, average clutch size and egg weight. A subset of the significant eigenvectors generated by the PC is shown in Table 4. PC1 clearly is an axis of RSD (for skeletal characters) since RSD levels for all four skeletal character complexes are significantly correlated with scores on PC1. The only non-skeletal variable to load significantly ($r > .63$) is percent weight difference (= RSD for weight). The only skeletal characters to load significantly on PCII are skull characters and these are associated (negatively) with percent mammals in the diet and (positively) with percent invertebrates in the diet. Figure 2 shows the position of the species on these 2 axes. They are well separated on PC1 but only *Glaucidium gnoma* is distinct on PC2.

It has been established here that females of these 10 species are generally larger than males for all 17 skeletal characters. It is useful to see if the relative size of skeletal characters (i.e., shape sensu Mosimann 1970) differs between the sexes. Table 5 gives relative trait lengths for character complexes. With few exceptions, females have relatively smaller heads, larger body cores and larger wings than do males. There are no obvious sexual differences in relative dimensions of leg bones.

The consistency of the shape differences between males and females suggests that shape changes may be associated with size and may not be related to sexual differences. To test this, I looked at the correlations between weight and relative size of character

Table 3.--Mean levels of sexual size dimorphism for character groups of 10 species of owls.

Character Group	Mean D.I.	S	N	t
Skull	1.79	2.58	10	2.19
Body	5.18	2.36	10	6.93**
Wing	4.69	2.36	10	6.29**
Leg	4.74	2.93	10	5.11**

** $P < .01$, t -test

complexes for each sex across the 10 species. Table 6 shows some consistent shape changes that are associated with weight differences among the 10 species. Therefore, regardless of sex, heavy owls tend to have relatively smaller heads, and relatively longer wing bones compared to lighter owls. The only male/female shape difference which does not seem related to size (weight) is the relatively large body core of females.

DISCUSSION

The concerns raised in the introduction over the choice of an appropriate character to measure RSD seem merited on examination of Table 1. The degree of RSD is quite variable among characters within each species. Combining characters into related complexes allows for reduction in the number of variables and should not obscure relationships

Table 4.--Significant eigenvectors¹ associated with a subset of the variables considered in a principal component analysis of skeletal sexual dimorphism, weight and ecological measures (from Mueller 1986).

Variable	PC1	PC2
Skull	0.64	-0.67
Body	0.92	--
Wing	0.92	--
Leg	0.86	--
Weight	--	--
Abs. wt. diff.	--	--
% wt. diff.	0.71	--
Wingloading	--	--
% mammals in diet	--	-0.89
% birds in diet	--	--
% inverts in diet	--	0.85
Clutch size	--	--
Egg weight	--	--

¹Eigenvectors expressed as the correlation between the original variables and the principal components.

Table 5.--Relative trait lengths of character complexes of owls [$= \frac{\sum_i X_{ij}}{\sum_j \sum_i X_{ij}}$, the sum of all characters (i) in complex (j) divided by the sum of all characters (all ij)]. Sample sizes are in parentheses (no. of males/no. of females).

	SKULL		BODY		WING		LEG	
	Males	Females	Males	Females	Males	Females	Males	Females
Nyctea scandiaca (16/22)	.170**	.165**	.307	.310	.324*	.326*	.213	.213
Bubo virginianus(53/79)	.179**	.175**	.280**	.283**	.302**	.305**	.256	.254
Strix nebulosa (25/49)	.201**	.195**	.279**	.283**	.305**	.307**	.246	.246
Strix varia (8/7)	.206	.202	.277	.276	.289	.290	.256	.258
Asio flammeus (51/32)	.179**	.175**	.281**	.284**	.314	.313	.241	.242
Surnia ulula (1/3)	.210	.214	.315	.319	.279	.275	.220	.216
Asio otus (11/4)	.197**	.193**	.273	.275	.301	.303	.249	.250
Aegolius funereus (8/1)	.252	.239	.296	.299	.258	.262	.226	.231
Aegolius acadicus (7/9)	.256*	.251*	.291	.290	.251*	.255*	.237	.237
Glaucidium gnoma (2/1)	.238	.225	.321	.322	.237	.243	.234	.238

* Difference between males and females significant at $P < .05$, t -test

** $P < .01$, t -test

since most characters in a complex are highly intercorrelated.

Table 2 shows no obvious patterns for these character complexes in the degree of RSD among species. Mueller (1986: 403) concludes that "the facilitation of female dominance is thus the most viable hypothesis on the evolution of RSD, in spite of the scarcity of data on dominance relationships." While I

Table 6.--Correlations between weight and relative size of groups of skeletal characters for male owls (above the diagonal) and for female owls (below the diagonal).

	Weight	Skull	Body	Wing	Leg
Weight	----	-0.73*	-0.14	0.73*	-0.03
Skull	-0.75*	----	0.31	-0.93**	-0.15
Body	-0.10	0.26	----	-0.49	-0.79**
Wing	0.76*	-0.92**	-0.44	----	0.13
Leg	-0.09	-0.09	-0.79**	.08	----

* $P < .05$

** $P < .01$

cannot comment directly on this hypothesis using data presented here, I would predict that closely related species would show similar male/female dominance relationships. Yet in this study, there was no tendency for congeneric species to show related levels or patterns of dimorphism.

The Snowy Owl and the Short-eared Owl are both migratory, open-country birds. They thus differ dramatically from the rest of the owls considered here which are relatively sedentary forest-dwelling species. Despite these major ecological differences, RSD values for Snowy and Short-eared Owls are very different and in no way distinctive from the forest-dwelling species. If these major ecological differences are not reflected in levels of RSD, how likely is it that subtle ecological factors such as: (1) variation in prey agility (Andersson and Norberg 1981, Safina 1984, Temeles 1985); (2) mode of nest defense (Wiklund and Stigh 1983); or (3) flight performance (Reynolds 1972, Andersson and Norberg 1981) are the key to understanding interspecific variation in levels of RSD.

Combining individual skeletal elements into groups is useful in comparing relative levels of dimorphism for different parts of

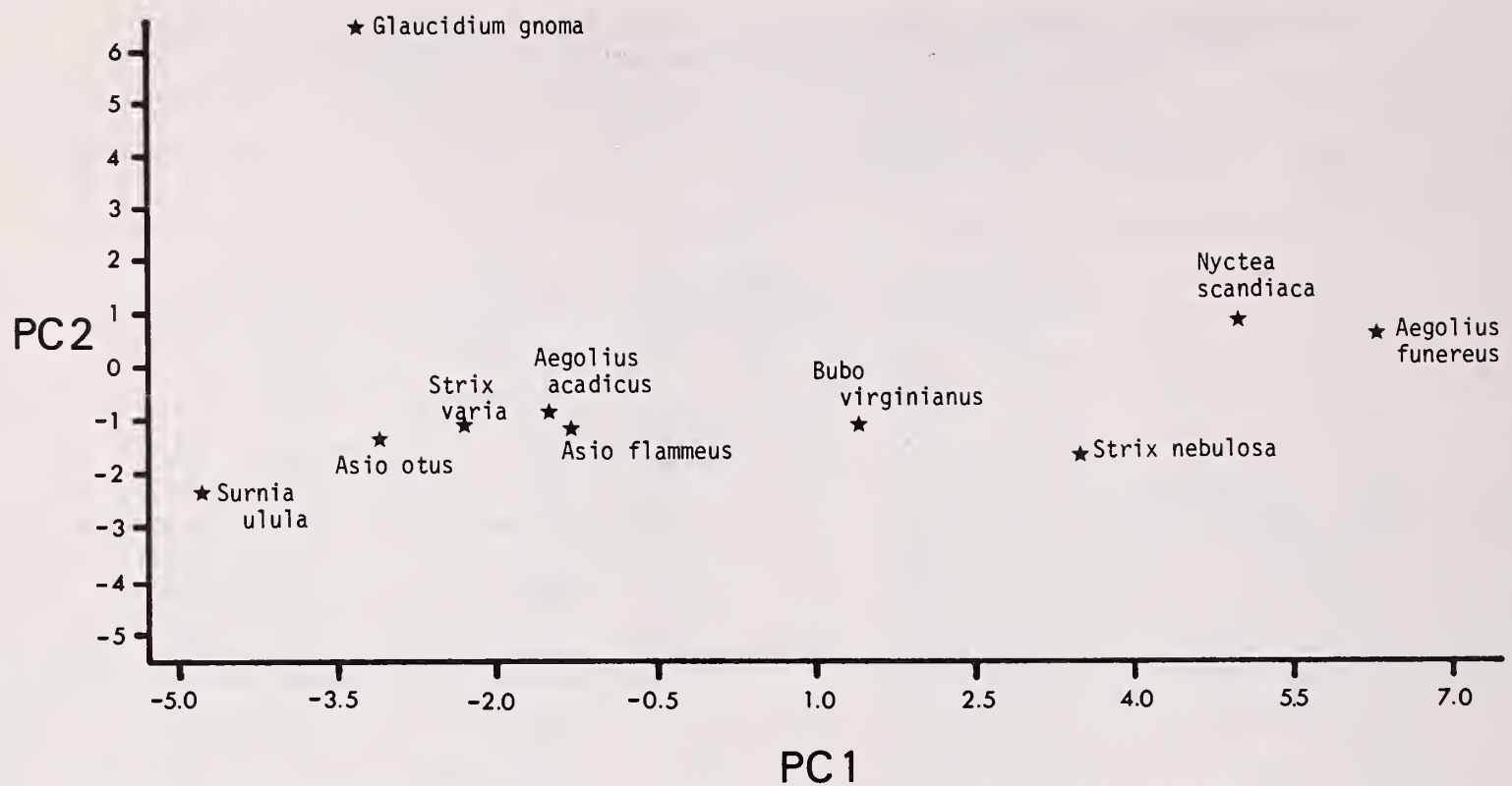

Figure 2.--Plot of species means on principal components 1 and 2 based on skeletal characters and a variety of ecological measures. PC1 appears to serve as an axis of RSD.

the skeleton. It is clear from Table 3, that skull elements are less dimorphic than either body core or limb elements. McGillivray (1985) suggested that relatively wide skulls in Great Horned Owl males might improve their ability to locate prey by sound. Evidence for this is not as convincing in other species with only *Asio otus* showing negative RSD (males larger than females) for skull width.

From a strict statistical standpoint, there was no correlation between RSD for character complexes and RSD for weight between males and females. However, I believe this is misleading because the correlation of body core characters and wing characters with RSD for weight are (.60) just below the .05 level of 0.63; and several component characters (coracoid, sternum, keel, carpometacarpus) show significant correlations. It would be very surprising from a theoretical standpoint to not find a relationship between skeletal dimensions and weight (Schmidt-Nielsen 1984). This relationship is further supported by the principal component analysis in which the only variable related to overall skeletal dimorphism was the percent weight difference between males and females.

The association on PC2 between low levels of skull dimorphism and a high insect, low mammal diet is intriguing but the plot (Fig. 2) reveals that this axis is created by *Glaucidium gnoma* which diverges dramatically from the rest of the species. Overall there is little support for the role of diet in modifying RSD which confirms Mueller's (1986) conclusion.

There are consistent shape differences between males and females of the species considered here. Males have relatively larger skulls but smaller body core and wing elements. However, Table 6 shows that these shape differences, with the exception of body core measures, are a function of size. In other words, there is no evidence for shape variation between males and females which is consistent with differing ecological roles. Table 6 (and 5) also indicate that despite their different habitat and behavior, these 10 species show virtually no shape differences other than those associated with size. The only exception appears to be leg elements where interesting variation is found. For instance the tarsometatarsus is very short in both *Nyctea scandiaca* and *Surnia ulula* relative to their overall size. The link between prey size, habitat, and climate and leg size in owls is worth further examination.

CONCLUSIONS AND RECOMMENDATIONS

The rank ordering of these 10 species by RSD as estimated on PC1 (Fig. 2) differs from the findings of Mueller (1986) and Earhart and Johnson (1970). However, in both these previous works the rank order depended on the variable used to measure RSD. For both studies, the correlation between RSD measured by wing and that measured by weight in North American owls is 0.78 (n=18, Mueller 1986; n=26, Earhart and Johnson 1970). This value is highly significant but it shows that only 61 percent of the variation in one measure can be accounted for by the other. Wing length

has been shown to be a poor measure of size in RSD studies (McGillivray 1985, Mueller 1986) and it was not considered here. Mueller (1986) concludes that weight is the best measure to use in estimating RSD. In this study RSD in weight is shown to be related to RSD for some body core and wing elements; although these correlations are generally weak. The question is: does adequate weight data on owls exist to continue using weight as an index of size? My assessment is no based on three considerations: (1) Wijnandts (1984) has shown that weights for female Long-eared Owls vary as much as 25% during the breeding season. Females gain considerable weight prior to and during incubation but lose it and more during the nestling period. Throughout this period, the female needs to remain mobile for nest defense and to escape predation, therefore the skeleto-musculature must be large enough to deal with the extra weight.

(2) Weight data obtained from museum specimens are biased because most owls are obtained as road kills or accidental casualties. These birds are often in poor condition when they died and weights are obtained after much dessication. As well for northern species, most individuals are acquired during migration or during southward movements in winter. Therefore, weight data are from outside the breeding season which likely underrepresents the extent of weight dimorphism (Wijnandts 1984, McGillivray 1985). An example from this study is for *Nyctea scandiaca*, for which virtually all specimens in North American museums are winter birds. The level of RSD for skeletal measures for Snowy Owls is very high (second only to *Aegolius funereus*) yet the level for weight is only 17.8% which ranks 3rd lowest among the 10 species. I would predict that weight dimorphism for Snowy Owls would be considerably higher than 17.8% if measured during the breeding season.

(3) All the weight data used are from one source. Mueller (1986) cites Dunning (1984) but Dunning obtained weights from Snyder and Wiley (1976) who used data from Earhart and Johnson (1970). For studies of RSD in North American owls, all the weight data originate with Earhart and Johnson (1970). Given our understanding of geographic variation in many species, and potential biases associated with museum specimens, a larger data base is required before we have adequate estimates of RSD in weight.

My recommendation is that attempts be made to obtain breeding season weight data such as acquired by Wijnandts (1984), but in lieu of that to use skeletal measures to estimate RSD. There is a good body of theory linking skeletal dimensions to mass (Schmidt-Neilsen 1984). Most skeletal differences between male and female owls examined here appear related to mass. A worthwhile area of study would be

an examination of the weight flux female owls undergo during the breeding season and how this varies among species. Selection for large size might occur if the female is required to gain considerable weight during incubation. If so, it may be necessary to reconsider the role of ecological factors in the evolution of RSD.

ACKNOWLEDGMENTS

I thank Dr. Sievert Rohwer, Thomas Burke Memorial Museum, Jim Dick, Royal Ontario Museum and Dr. R. Zusi, U.S. National Museum for loaning specimens under their care. Special thanks are given to Pauline Erickson for her assistance in measuring many of the specimens and in preliminary data analysis. Colleen Steinhilber is gratefully acknowledged for her typing. Dr. Jim Burns prepared Figures 1 and 2 and S. McGillivray improved the paper with her comments.

LITERATURE CITED

- Andersson, M. and R.A. Norberg. 1981. Evolution of reversed sexual size dimorphism and role partitioning among predatory birds, with a size scaling of flight performance. *Biol. J. Linn. Soc.* 15: 105-130.
- Atchley, W.R., C.T. Gaskins, and D. Anderson. 1976. Statistical properties of ratios I. Empirical results. *Syst. Zool.* 25: 137-148.
- Cherry, L.M., S.M. Case, J.G. Kunkel, J.S. Wyles and A.C. Wilson. 1982. Body shape metrics and organismal evolution. *Evolution* 36: 914-933.
- Dunning, J.B. Jr. 1984. Body weights of 686 species of North American birds. *West. Bird Band. Assoc. Monogr.* 1.
- Earhart, C.M. and N.K. Johnson. 1970. Size dimorphism and food habits of North American owls. *Condor* 72: 251-264.
- Jehl, J.R. and B.G. Murray, Jr. 1986. The evolution of normal and reverse sexual size dimorphism in shorebirds and other birds. *Current Ornithol.* 3: 1-86.
- Johnston, R.F. and R.C. Fleischer. 1981. Overwinter mortality and sexual size dimorphism in the House Sparrow. *Auk* 98: 503-511.
- McGillivray, W.B. 1985. Size, sexual size dimorphism and their measurement in Great Horned Owls in Alberta. *Can. J. Zool.* 63: 2364-2372.
- Mosimann, J.E. 1970. Size allometry: size and shape variables with characterizations of the lognormal and generalized gamma distributions. *J. Am. Stat. Assoc.* 65: 930-945.

- Mueller, H.C. 1986. The evolution of reversed sexual dimorphism in owls: an empirical analysis of possible selective factors. *Wilson Bull.* 98: 387-406.
- Mueller, H.C. and K. Meyer. 1985. The evolution of reversed sexual dimorphism in size: A comparative analysis of the Falconiformes of the western Palearctic. *Current Ornithol.* 2: 65-101.
- Payne, R.B. 1984. Sexual selection, lek and arena behavior and sexual dimorphism in birds. *Ornithol. Monogr.* 33: 1-42.
- Reyment, R.A., R.E. Blackith and N.A. Campbell. 1984. *Multivariate morphometrics.* 2nd ed. Academic Press, London, England.
- Reynolds, R.T. 1972. Sexual dimorphism in accipiter hawks: a new hypothesis. *Condor* 74: 191-197.
- Safina, C. 1984. Selection for reduced male size in raptorial birds: the possible roles of female choice and mate guarding. *Oikos* 43: 159-164.
- SAS Institute. 1985. *SAS user's guide: statistics.* SAS Institute Inc., Cary, NC.
- Schmidt-Nielsen, K. 1984. *Scaling: why is animal size so important?* Cambridge Univ. Press, Cambridge.
- Schnell, G.D. 1970. A phenetic study of the suborder Lari (Aves)/I. Methods and results of principal components analyses. *Syst. Zool.* 19: 35-57.
- Snyder, N.F.R. and J.W. Wiley. 1976. Sexual size dimorphism in hawks and owls of North America. *Ornithol. Monogr.* 20: 1-96.
- Somers, K.M. 1986. Multivariate allometry and removal of size with principal components analysis. *Syst. Zool.* 35: 359-368.
- Storer, R.W. 1966. Sexual dimorphism and food habits in three North American accipiters. *Auk* 83: 423-436.
- Temeles, E.J. 1985. Sexual size dimorphism of bird-eating hawks: The effect of prey vulnerability. *Amer. Natur.* 125: 485-499.
- Wijnandts, H. 1984. Ecological energetics of the Long-eared Owl (*Asio otus*). *Ardea* 72: 1-92.
- Wiklund, C.G. and J. Stigh. 1983. Nest defence and evolution of reversed sexual size dimorphism in Snowy Owls *Nyctea scandiaca*. *Ornis Scand.* 14: 58-62.

Disease Susceptibility in Owls¹

D. Bruce Hunter,² Kay McKeever,³ Larry McKeever,³
and Graham Crawshaw⁴

Abstract.--Disease may be a significant factor in the population dynamics of free-living species. Subclinical disease may alter food gathering capabilities, ability to escape predators and reproductive success. This paper describes three disease outbreaks in owls: Hippoboscid fly infestation, Cyathostoma americana (gapeworm) infestation and fungal pneumonia, (Aspergillosis) to illustrate that disease can impact recruitment and survivability of owls.

INTRODUCTION

Disease is any process which alters normal body function and results in decreased production and survivability. Disease may be caused by infectious agents, nutritional deficiencies or excesses, environmental toxins or genetic or congenital accidents. Studies in commercial livestock and zoological collections show that although some diseases may cause overt sickness and mortality most diseases are subclinical and interfere with either normal growth, behavior or alter reproductive success but do not necessarily kill the host. Commercial animal production industries go to great expense to monitor their animals for signs of subclinical disease which may affect the profitability of the enterprise.

¹Paper presented at the Northern Owl Symposium. [Winnipeg, Manitoba, February, 1987].

²D. Bruce Hunter is Associate Professor of Avian Pathology, Ontario Veterinary College, University of Guelph, Guelph, Ontario.

³Kay and Larry McKeever are Co-founders of The Owl Rehabilitation and Research Foundation, Vineland Station, Ontario.

⁴Graham Crawshaw is Staff Veterinarian at the Metropolitan Toronto Zoo, Toronto, Ontario.

Naturally occurring disease is seldom considered to be an important factor in recruitment and livability of owls and yet in the present symposium data from several speakers showed survivability in young owls to be as low as 20% by the second year of life. "Starvation", "killed by a Great Horned owl", "fell from the nest site," eggs failed to hatch" were all given as reasons for mortality but complete post mortems were seldom performed to confirm the immediate cause of death or the presence of concurrent disease. It is possible that subclinical disease, whether due to hematozoan or ectoparasite infestation causing marginal anemia, neonatal bacterial diarrhea or septicemia, sublethal levels of a pesticide, or even limited prey availability causing subnormal growth efficiency may alter a young owl's ability to secure prey or render the owl more susceptible to predation. Factors which alter survivability during the first year of life are important and poorly understood pieces of the natural history puzzle of owls. The following examples of specific diseases in owls serve to illustrate some of the factors that may influence an owl's susceptibility to disease and further emphasize that disease can have a significant effect on survivability and recruitment.

Example #1

Biting flies of the family Hippoboscidae are common on birds of prey but are usually considered to be non-pathogenic commensals. In August 1983 a Hawk owl (*Surnia ulula*) kept in a captive propagation project was found weakened from anemia caused by a heavy infestation of blood sucking Hippoboscids. Examination of other owls in the collection showed that several species, in particular Great gray owls (*Strix nebulosa*) and Hawk owls, had significant numbers of Hippoboscids. Hippoboscids could be found firmly attached along the base of blood quills of remiges and retrices of affected birds. These observations led to a small study in 1984 to determine:

- (1) if northern owl species were particularly susceptible to Hippoboscid fly infestation.
- (2) if Hippoboscid flies caused anemia
- (3) if moulting patterns of the owls influenced severity of infestation.

In order to interfere minimally with the breeding project owls were handled only three times: during mid to late July, mid-August (peak of Hippoboscid infestation in 1983) and early October. At each handling birds were examined for Hippoboscids, a blood sample obtained from the ulnar vein for packed cell volume (PCV) and total plasma protein (TP) and the progression of moult documented.

Table 1 shows the distribution of species infested with Hippoboscid flies. Great gray owls and hawk owl harboured the largest number of flies but the Snowy owl (*Nyctea scandiaca*) had few flies. Packed cell volumes (table 2) decreased in August corresponding to the heaviest Hippoboscid infestation. As there were no parasite negative control owls in this study it was not possible to rule out normal seasonal fluctuations of PCV but species such as the Great horned owl (*Bubo virginianus*) and Barred owl (*Strix varia*) which harboured low numbers of Hippoboscids did not show an August decrease in PCV. Hippoboscid infestation appeared to be related to the moulting pattern of the bird (fig. 1). Hawk owls and Great gray owls were in heavy moult during the peak

Table 1.--Hippoboscid fly infestation in several species of owls.

Species of owl	Sample size	Number of flies (mean + standard deviation)	Observation date
Great gray	6	175 + 28	August 8
Snowy	4	6 + 5	August 23
Hawk	1	150 + 0	August 8
Barred	3	8 + 2	August 23
Great horned	1	30 + 0	August 23
	1	4 + 0	August 29
Short eared	3	47 + 16	August 23
	3	2 + 1	August 29
Long eared	1	40 + 0	August 23
	4	5 + 3	August 29

Table 2.--Hematology (Packed cell volume and total plasma protein) in owls before, during and after emergence of Hippoboscid flies.

Species of owl	Date	Sample size	PCV(%)		T.P. (g/100ml)	
			mean	s.d.	mean	s.d.
Great gray	July 5	6	44	+ 4	4.2	+ 0.5
	Aug. 15	6	32	+ 8	3.5	+ 0.4
	Oct. 3	12	38	+ 5	4.3	+ 0.5
Snowy	July 6	3	42	+ 1	5.9	+ 1.0
	Aug. 16	3	32	+ 3	4.9	+ 0.7
	Oct. 3	5	37	+ 5	5.3	+ 0.6
Hawk	July 30	2	40	+ 1	4.0	+ 0.5
	Aug. 15	2	33	+ 2	3.8	+ 0.7
	Oct. 4	5	46	+ 7	4.5	+ 0.4
Barred	July 30	3	34	+ 3	4.7	+ 0.5
	Aug. 16	3	36	+ 4	4.8	+ 0.6
	Oct. 6	4	41	+ 3	5.1	+ 0.5
Great horned	July 6	5	38	+ 2	4.2	+ 0.8
	Aug. 1	5	45	+ 5	4.4	+ 0.5
	Oct. 4	4	38	+ 4	4.5	+ 0.1

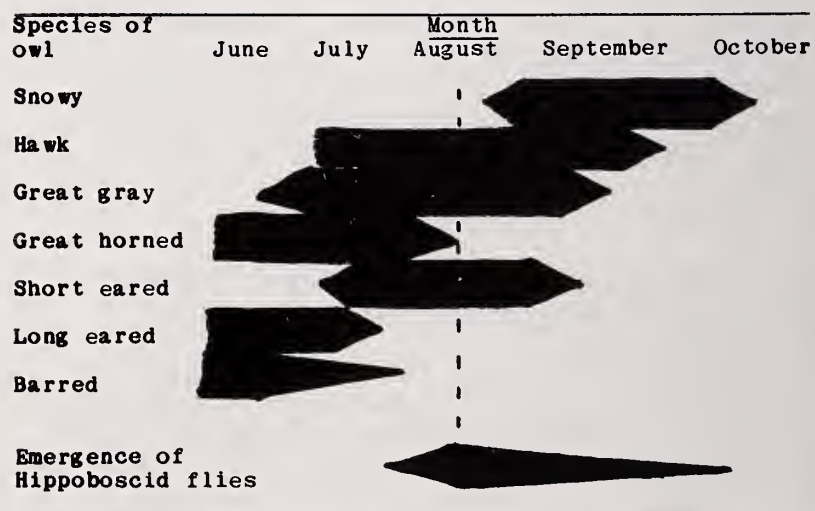

Figure 1.--Moulting pattern in owls, raised in a captive breeding project in southern Ontario, correlated with the emergence of Hippoboscid flies.

emergence of Hippoboscid flies. Owl species with fewer Hippoboscids appeared to be either finished their moult or as in the case of the Snowy owls not yet begun their moulting period. The feeding pattern of the Hippoboscid flies along the base of "in blood" feather quills supports the observation that birds in active moult are most heavily parasitised.

Example #2

Respiratory tract nematodes Syngamus sp. and Cyathostoma sp. have been occasionally reported from the respiratory tract of diurnal birds of prey (Chapin 1925, Bougerol 1967, Cooper 1985). In 1979 we identified Cyathostoma americana as the cause of death in a wild Saw whet owl (Aegolius acadicus) which had been admitted for trauma injury 10 days earlier. The following year Cyathostoma americana was responsible for the death of a hawk owl which had been maintained in captivity for several years. In 1986 Cyathostoma americana caused death in 5 of 13 juvenile Burrowing owls (Athene cunicularia) raised in a propagation release project in southern Ontario. Large numbers of worms were recovered from abdominal, cervical and clavicular air sacs, lung and primary bronchi from affected birds. All birds had severe airsacculitis and generalized necrotizing pneumonitis in response to aspirated nematode eggs and migration of adult worms (fig. 2). The original



Figure 2.--Lung of Sawwhet owl with a heavy infestation of the nematode Cyathostoma americana.

source of the parasite for this Burrowing owl colony is unknown but the owls have access to both earthworms which may act as intermediate host and to shrews (Blarina brevicauda) and star-nosed moles (Condylura cristata) which may act as paratenic hosts. Control of the parasite was accomplished by antihelminthic therapy combined with management changes aimed at controlling earthworms. In late 1986 a wild eastern Screech owl (Otus asio) was admitted to the clinic for traumatic injury and died within a few days with massive parasitic pneumonia caused by Cyathostoma americana.

Example # 3

Aspergillus fumigatus causes respiratory disease in all birds of prey. Clinical disease is usually a result of massive exposure of Aspergillus spores or the bird being immunosuppressed from some concurrent disease process or other stressors. In our experience at both the Ontario Veterinary College Wild Bird Clinic and the Owl Rehabilitation and Research Foundation northern owl species such as the Snowy owl, Great Gray owl and Boreal owl (Aegolius funereus) are very susceptible to Aspergillosis compared to more southernly species. These northernly species usually present with acute, fulminating Aspergillosis with massive fungal growth, invasion of blood vessels, lungs and other body organs rather than the more chronic localized lesions found commonly in more southernly owl species.

DISCUSSION

The three examples of disease in this paper were chosen to illustrate the complexity of host/parasite interrelationships. In order for disease to occur it is necessary to have a susceptible (non-immune) host, a pathogenic (disease causing) organism and an environment suitable to allow the host and disease causing agent to interact. The Hippoboscid infestation revealed that under certain environmental conditions an organism normally considered to be a commensal can cause anemia or even death. In this case the critical

environmental factors included the emergence of the Hippoboscid flies and the timing of the seasonal moult of the birds. Most of the owls developed a marginal anemia during the period of infestation. It is interesting to speculate whether a similar mild anemia in a wild owl would decrease food gathering ability or increase susceptibility to predation. Many raptors presented to our clinic have a marginal anemia and moderate to low levels of blood parasites, particularly Hemoproteus sp. and Leucocytozoon sp. As these agents are transmitted by biting arthropods it would be interesting to study nestling owls which are commonly infested with mosquitoes or black flies to determine if parasite induced hematologic changes may correlate with fledgling survivability.

The death of the captive Burrowing owls and the wild Sawwhet and Screech owl indicate that Cyathostoma americana is a potential pathogen. The high mortality in the Burrowing owl colony was undoubtedly related to housing and confinement of the birds; however, identifying Cyathostoma as the cause of death in wild Ontario owls raises questions about the significance of this parasite in owl species which feed on earthworms, shrews or moles.

Aspergillosis is well described in many avian species. Our experiences have shown that northerly species such as the Snowy owl, Hawk owl, Gyr falcon (Falco rusticolus), Rough-legged hawk (Buteo lagopus), Eider duck (Somateria sp.), Old Squaw duck (Clangula hyemalis) are very susceptible to fungal infections. This may be due to a lack of exposure to fungal spores in their home environment, to immunosuppression from migratory stressors, nutrition changes or stresses within our hospital environments. There have been no

studies to investigate comparative immune responses among species of owls.

In summary disease processes may affect species population dynamics in more subtle ways than killing the host. Subclinical disease may be an important factor in reproductive success and livability of wild owl populations. Our knowledge of naturally occurring disease in owls is very limited and it would be highly desirable for field biologists and veterinary pathologists to develop cooperative studies to investigate this fascinating aspect of owl biology.

LITERATURE CITED

- Appleby, E.C. 1962. Mycosis of the respiratory tract in penguins. Proceedings of the Zoological Society London 139:495-501.
- Bougerol, C. 1967. Essai sur la pathologie des oiseaux de chasse au vol. Alfort, France.
- Chapin, E.A. 1925. Review of the Nematode genera Syngamus Sieb. and Cysathostoma E. Blanchard. Journal Agricultural Research 30:557-570.
- Cooper, J.E. 1985. Veterinary aspects of captive birds of prey. The Standfast Press. page 89-90.
- Redig, P.T. 19 . Aspergillosis in raptors. p. 117-122. In Recent advances in the study of raptor diseases. Cooper, J.E. and Greenwood, A.G. editors. Chiron Publications, Keighley, Yorkshire.
- Sladen, W.J.R., Divers, B.G. and Garley-Phipps, J.J. 1979. Medical problems and treatment of penguins at the Baltimore Zoo. International Zoo Yearbook 19:202-209.

The Role of the Whitefish Point Bird Observatory in Studying Spring Movements of Northern Forest Owls¹

Thomas W. Carpenter²

Abstract.--The Whitefish Point Bird Observatory has had a spring owl banding program since its formation in 1978. Barred, Boreal, Great Horned, and occasionally Great Gray Owls are captured, in addition to the normally migrant Long-eared and Northern Saw-whet Owls. Thus, the observatory plays an important role in studying northward movements of many northern forest owls which move south out of the boreal forest during the winter. I summarize the 1978-1986 owl banding data and briefly explain future objectives for the observatory's owl banding program.

INTRODUCTION

The presence of significant numbers of owls was first noted at Whitefish Point, Chippewa County, Michigan during the spring of 1966 when mist nets set up to capture Sharp-shinned Hawks (*Accipiter striatus*) were left open at night. From 1966 to 1970, 280 owls of 6 species were banded at the point (Kelley and Roberts 1971). From 1971 to 1977 limited owl banding was done at the point, usually for only a couple weeks each spring. In 1978 the Whitefish Point Bird Observatory (WPBO) was formed and owl banding coverage improved dramatically as a result. In this paper I will summarize owl banding at WPBO from 1978-1986 and mention some studies that are currently underway.

METHODS

Because WPBO's banding program relies strictly on volunteer banders, it was not possible to have coverage

¹Paper presented at the symposium, Biology and Conservation of Northern Forest Owls, Feb. 3-7, 1987, Winnipeg, Manitoba. USDA Forest Service General Technical Report RM-142.

²Thomas W. Carpenter, Whitefish Point Bird Observatory, 3646 S. John Hix, Wayne, Michigan 48184.

for the entire spring. Banding coverage varied as follows: 2 wk in 1978; 2.5 wk in 1979; 6 wk in 1980-1983, 1985-1986; and 5 wk in 1984. The last week of April and the first week of May had coverage during all years. The earliest coverage ever began was the last week of March (1981 and 1983) and the latest it continued was through 9 June (1982).

Six to 22 mist nets were operated during the periods of coverage. The number of nets depended on the number of banders present and their levels of experience. During the first 4 years both 61 mm and 121 mm stretched mesh mist nets were used. From 1982-86 almost all nets used were 121 mm stretched mesh. Accurate net hour information, the locations where nets were placed and the net locations where owls were captured were not regularly recorded until 1984.

Luring for larger owls (Great Horned, *Bubo virginianus*; Long-eared, *Asio otus*; Barred, *Strix varia*; and Great Gray, *Strix nebulosa*) with pigeons and starlings took place at dusk during a few nights most years, usually during April. Birds were either lured into mist nets (Grigg 1975) or were captured with bownets when they bound to the lure bird.

During 1980, 1983 and 1984 a few owls were also captured with 3 to 6

Table 1.--Numbers of owls banded at Whitefish Point Bird Observatory, 1978-86.

<u>Species</u>	<u>1978</u>	<u>1979</u>	<u>1980</u>	<u>1981</u>	<u>1982</u>	<u>1983</u>	<u>1984</u>	<u>1985</u>	<u>1986</u>	<u>Total</u>
Great Horned Owl					1	15	36	5	10	67
Barred Owl	3	4	3	2	11	4	38	3		68
Great Gray Owl			2	1		1	11	3	1	19
Long-eared Owl	24	23	29	144	18	24	23	20	49	354
Boreal Owl	23	7	2		36	18	47	5	1	139
Northern Saw-whet Owl	18	20	25	50	23	77	63	38	93	407
										<u>1,054</u>

automatic bownets baited with mice, pigeons and starlings.

RESULTS AND DISCUSSION

There have been 1,054 owls of 6 species banded since WPBO was formed as summarized in table 1. The first owls are usually captured during late March to early April (table 2). Movements continue well into May during some years and at least into early June for the Northern Saw-whet Owl (*Aegolius acadicus*). Nights with heavy movement (10 or more owls/night) can occur anywhere from mid April to mid May and are very variable and unpredictable. During some years there are several nights with heavy movement and during other years there is never even a single night with heavy movement.

Except for some of the Northern Saw-whet and Long-eared Owls, most if not all of the owls captured are probably non-breeding individuals as breeding birds

Table 2.--Earliest and latest capture dates for owls banded at Whitefish Point Bird Observatory, 1978-86.

<u>Species</u>	<u>Earliest</u> <u>Capture</u> <u>Date</u>	<u>Latest</u> <u>Capture</u> <u>Date</u>
Great Horned Owl	25 Mar	25 May
Barred Owl	27 Mar	21 May
Great Gray Owl	10 Apr	21 May
Long-eared Owl	3 Apr	5 Jun
Boreal Owl	7 Apr	27 May
Northern Saw-whet Owl	1 Apr	8 Jun

would already be on their breeding territories prior to the initiation of our banding operations (see breeding dates in Bent 1961, Adamcik et. al. 1978b, Bondrup-Nielsen 1978, Nero 1980).

Since it has only been from 1984-86 that capture effort has been quantified, I will not attempt to make any detailed analyses of the numbers captured each year. However, enough coverage was available each year to make some gross interpretations of the data.

Long-eared and Northern Saw-whet Owls are the only species that are captured in good numbers every spring. The numbers of Long-eared Owls banded are usually fairly constant, though 1981 was a year they were exceptionally abundant. WPBO is currently studying sexing methods for this species. The numbers of Northern Saw-whet Owls appear to fluctuate more widely but since capture effort was not quantified for most years, comparisons between years would be meaningless. Weather (Mueller and Berger 1967, Evans 1980, Weir et. al. 1980) and the proportion of juvenile birds (Weir et. al. 1980) significantly affect numbers captured for this species in fall movements. WPBO is currently studying the effects of weather on the numbers of owls captured. Aging this species is much more difficult in spring than in fall; therefore, we have not been able to examine whether the proportion of juveniles to adults varies much from year to year. We hope to be able to address this question in the future as more of our banders become experienced at aging this species.

The numbers of Boreal Owls (*Aegolius funereus*) appear to be cyclical, with good numbers being present for 3 years followed by 2 years of few or no birds. However, more years of data will be necessary to

confirm this pattern. WPBO appears to be the best place in the United States to study the magnitude of southward movements of this species. Boreal Owls are seldom captured during fall (Evans and Rosenfield 1977) and apparently do not usually leave the boreal forest until winter is well underway. WPBO captures birds returning north in the spring so that the relative numbers of birds that left the boreal forest the preceding winter can be evaluated. It is interesting to note that even when this species does come south of the boreal forest it is sometimes not detected. In 1983 we captured fairly good numbers of Boreal Owls and there were no reported influxes for the winter of 1982-83 (Powell 1983, Weir 1983). WPBO is currently studying sexing methods for this species and we hope to be able to evaluate the age and sex composition of future influxes.

The numbers of the larger owls (Barred and Great Gray) banded prior to 1982 cannot be compared with later years due to extensive use of 61 mm stretched mesh mist nets during significant periods of banding coverage from 1978 to 1981. The 61 mm nets do not effectively capture large owls.

The number of Barred Owls appears to fluctuate considerably. This species was exceptionally abundant in 1984 and none were captured during 1986 even though there was excellent banding coverage during this year. The spring of 1984 was preceded by a large invasion of Barred Owls into Minnesota (Powell 1984) and Ontario (Weir 1984) during the winter of 1983-84. Whether this species fluctuates in a predictable cyclical fashion will require more years of data.

Great Gray Owls are captured in small numbers during most years. In the spring of 1984, which preceded a huge invasion by this species into Manitoba (Nero et. al. 1984), Ontario (Weir 1984) and Minnesota (Powell 1984) during the winter of 1983-84, more than usual were banded. Not enough years of data are available yet to examine cyclical fluctuations in this species.

Great Horned Owls are seldom successfully captured in mist nets. Thus, luring and trapping with automatic bownets provide the best methods to assess the occurrence of this species. The 10 year cyclical pattern of southward movement out of the boreal forest has been well documented for this species (Keith 1963, Adamcik et. al. 1978a, 1978b, Houston this symposium). The springs of 1983 and 1984 followed such invasions (Powell 1983, 1984; Weir 1983, 1984) and our data show that this species was abundant in these years. However, we

usually captured some Great Horned Owls each year that an effort was made to do so (1982-86). We plan to make luring a routine part of our banding operation so that we can better study movements of this species.

Three owls have been captured in subsequent springs- a Boreal Owl 2 years after initial banding (Carpenter 1985) and 2 Barred Owls a year after initial banding.

Some owls are recaptured again one or more nights following the initial date they were banded. All of the Long-eared and Northern Saw-whet Owls and most individuals of the other species were recaptured within a week of the initial banding date. However, 5 Barred Owls were recaptured 8 to 17 nights after their initial banding date, 3 Great Gray Owls were recaptured 13 to 24 nights after their initial banding date, 4 Boreal Owls were recaptured 14 to 29 nights after their initial banding date and a Great Horned Owl was recaptured 16 nights after the initial banding date.

In summary, WPBO is a unique spot for studying the northward movements of northern forest owls that moved south of their breeding range in the boreal forest during the preceding fall and winter. In addition to the annually migrant Long-eared and Northern Saw-whet Owls, we also are able to study Boreal, Great Gray, Great Horned and Barred Owl movements. In future years we plan to better quantify capture effort so that comparisons from year to year will be more meaningful.

ACKNOWLEDGEMENTS

I wish to acknowledge the following banders who have helped provide owl banding coverage during the years of this study: Thomas Allen, Arthur Carpenter, James Devereux, Jeffry Dykehouse, Robert Grefe, William Grigg, Thomas Heatley, Micheal Jones, Alfred Knutsen, Warren Lamb, Daniel Miller, Craig Weatherby, and Bruce Winchell. Pertti Saurola also provided helpful suggestions on some aspects of this paper. This paper is a contribution of the Whitefish Point Bird Observatory.

LITERATURE CITED:

- Adamcik, R. S. and L. B. Keith. 1978a. Regional movements and mortality of Great Horned Owls in relation to Snowshoe Hare fluctuations. Canadian Field-Naturalist 92: 228-234.

- _____, A. W. Todd and L. B. Keith. 1978b. Demographic and dietary responses of Great Horned Owls during a Snowshoe Hare cycle. *Canadian Field-Naturalist* 92:156-166.
- Bent, A. C. 1961. Life histories of North American birds of prey (part 2). Dover. New York, N. Y.
- Bondrup-Nielsen, S. 1978. Vocalizations, nesting and habitat preferences of the Boreal Owl (*Aegolius funereus*) in North America. M. S. thesis. Univ. of Toronto, Toronto, Ontario.
- Carpenter, T. W. 1985. Recapture of a non-breeding Boreal Owl 2 years later. *Raptor Research* 19:142.
- Evans, D. L. and R. N. Rosenfield. 1977. Fall migration of Boreal Owls. *Loon* 49:165-167.
- _____. 1980. Multivariate analyses of weather and fall migration of Saw-whet Owls at Duluth, Minnesota. M. S. thesis, North Dakota State Univ., Fargo, N. D.
- Grigg, W. N. 1975. A proven way of catching adult Great Horned Owls. *Inland Bird Banding News* 47:16-17.
- Keith, L. B. 1963. Wildlife's ten year cycle. Univ. of Wisconsin Press. Madison, Wisc.
- Kelley, A. H. and J. O. L. Roberts. 1971. Spring migration of owls at Whitefish Point. *Jack-Pine Warbler* 49:65-70.
- Mueller, H. C. and D. D. Berger. 1967. Observations on migrating Saw-whet Owls. *Bird-Banding* 38:120-125.
- Nero, R. W. 1980. The Great Gray Owl. Smithsonian Institution Press. Washington, D. C.
- _____, H. W. R. Copeland and J. Mezibroski. 1984. The Great Gray Owl in Manitoba, 1968-83. *Blue Jay* 42:130-151.
- Powell, D. J. 1983. Western Great Lakes region. *American Birds* 37:303-306.
- _____. 1984. Western Great Lakes region. *American Birds* 38:319-321.
- Weir, R. D., F. Cooke, M. H. Edwards, and R. B. Stewart. 1980. Fall migration of Saw-whet Owls at Prince Edwards Point, Ontario. *Wilson Bulletin* 92:475-488.
- _____. 1983. Ontario region. *American Birds* 37:296-299.
- _____. 1984. Ontario region. *American Birds* 38:310-314.

Reintroduction of the Ural Owl in the Bavarian National Park, Germany¹

Wolfgang T. Scherzinger²

In the mountains of the Bavarian Forest an isolated population of Ural Owls became extinct in the beginning of the 20th century. Reintroduction trials were started in 1972 by building a breeding stock, releasing zoo-born owlets, monitoring them with radio transmitters, and studies of habitat preference. A total of 123 owls were bred in captivity; of 76 released in the field, 10 were found dead. Only 5 birds have settled in the area. Problems occurred with risk of hybridization with the Tawny Owl (*Strix aluco*), long-distance dispersal of young owls, and low prey abundance during severe winters.

INTRODUCTION

Strix uralensis is a big, long-tailed wood-owl, with small black eyes, and radial marks on the facial disk; its body and head are heavily streaked, and it has broadly barred tailfeathers (fig. 1). (The German name "Habichtskauz" suggests convergent characters with the Goshawk).

In the Bohemian Forest, which reaches along the border from Bavaria/Germany (Bavarian Forest) through Austria to Czechoslovakia, the Ural Owl existed until the beginning of the 20th century. Actual knowledge is based on nesting records, shootings, and from taxidermists' reports. Only in Schwarzenbergs principality, in the area of Schattawa, were these owls monitored more systematically to the end of the last century (Wust 1986). Detailed data on population levels, abundance, or habitat choice are totally lacking. The last records are from 1926 (Kucera 1970; fig. 2).

The main distribution area of this species is to be found in Scandinavia, Siberia, and reaches to Japan. In the montane regions of Central and Eastern Europe, isolated populations have remained from the post-glacial period. Some journeys were made to study recent habitats of the subspecies *Strix uralensis macroura* in Czechoslovakia. This also occurred in the Bohemian/Bavarian Forest (fig. 3). In Eastern Slovakia, the Ural Owl lives in old mixed forest in lower montane areas with

¹Paper presented at the symposium, Biology and Conservation of Northern Forest Owls, Feb. 3-7, Winnipeg, Manitoba. USDA Forest Service General Technical Report RM-142.

²Dr. Wolfgang Scherzinger is zoologist at Bavarian Forest National Park office, D 8352 GRAFENAU, FR-Germany.

oak trees or beech and fir. For breeding it primarily uses large Goshawk nests (Danko and Svehlik 1971).

THE PROJECT

In 1972 I was asked to develop a breeding project for a reintroduction experiment. Altogether we established five breeding pairs (the owls came from Sweden, Russia, Czechoslovakia, and



Figure 1.--An aggressive male Ural Owl.

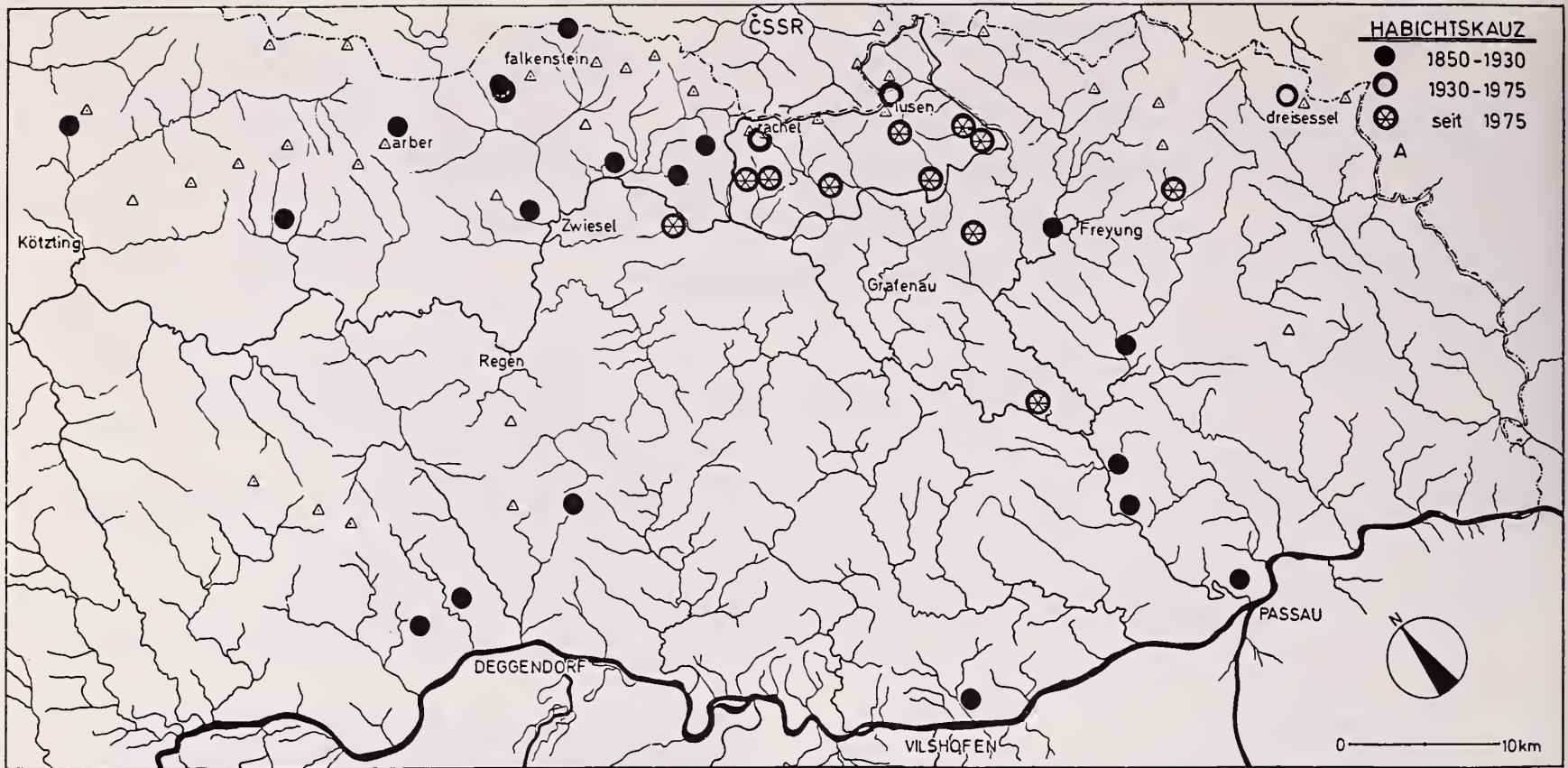

Figure 2.--Historical Ural Owl records in Bavarian Forest.

Yugoslavia, mostly from zoos). Fourteen of our offspring were offered to private breeders and zoos with the aim of founding a breeders association for this project. Between 1973 and 1986 an average of 2.5 eggs were laid per initiated brood (n=60), which means 2.7 eggs per clutch. Egglaying started, on the average, on 21 March; re-nesting occurred until the beginning of May. Altogether 97 owlets were born (mean value = 1.7 nestlings per brood; 9x1, 12x2, 12x3, 7x4 young). Three died, so the final breeding success was 94 fledglings (Scherzinger 1974, table 1).

This success was the result of very good breeding conditions. Individual pairs were kept in aviaries measuring at least 4 by 8m, with large nestboxes (30 by 30cm base). We fed only freshly

killed mice and rats from the breeding farm (no chickens and no frozen food). The aviaries were situated in optimal habitat, each 1 to 3 km apart, so the young owls could be released right there.

For the reintroduction experiment we got 94 young from our breeding stock and 29 from the breeders association, for a total of 123 in 12 years. Seventy-six owls were released in the field, and 47 were kept in stock or given to breeders.

We have learned much about releasing techniques with the Eagle Owl project in our national park (Scherzinger 1987), and have also gained essential ontogenetic data from the breeding results in captivity (fig. 4). Young *Strix uralensis* are fully able to fly within 40 days; they change to adult plumage when 10 weeks



Figure 3.--The smooth mountains of Bavarian Forest national park are totally covered by woodland (photo: H. Strunz).

Tab. 1.-- Success of breeding Ural Owl in captivity (1973-1986).

breeding stock	1-5 paires in nationalpark 1-4 paires in breeders ass.
egglaying starts	∅ March 21 (1.3.-1.5.)
clutch size	∅ 2,5 eggs /init. brood 2,7 eggs /clutch
youngs hatched	97 1,7 young/brood (n=57)
youngs grown up	94 1,6 young/brood 2,5 young/successf.brd.
youngs breed.ass.	29
reproduction total	123
breeding stock	22
Ural Owls total	145 ex.

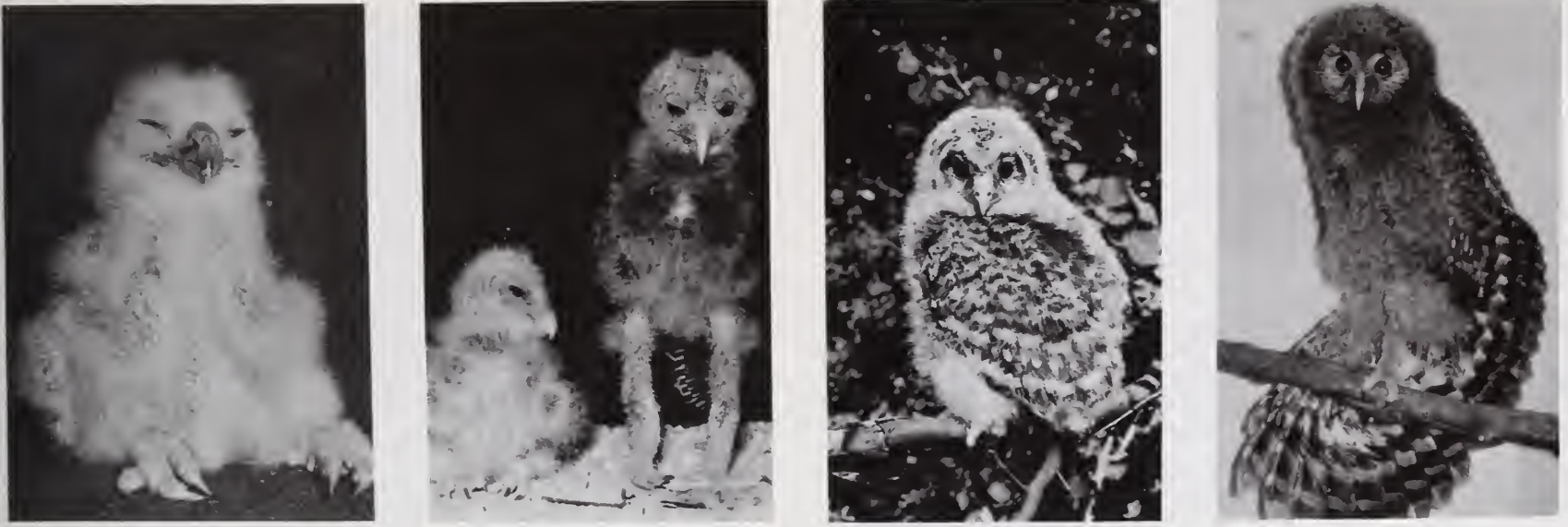

Figure 4.--Ontogenetic development of Ural Owl: 2, 16, 30, and 45 days of age.

old; the begging period ends during their 3rd month of life. The behavior for catching prey does not need to be learned (Scherzinger 1980). It is not necessary either to train the owls with live prey, if they have the opportunity to frequent a feeding place in the field. Ural Owls are most aggressive hunters, and feed on their own prey a few days after release.

The best age for setting them free is between 100 and 120 days. In this ontogenetic stage, plumage of adults is fully developed, the family context loosens, and the young owls are able to catch prey independently. During release, avoidance of stress or shock must be considered. Therefore it is necessary to do all the measurement, banding, and mounting of radios at least 3-5 days before release, so the birds have time to reassure themselves. They should be released at early dawn on days without wind or precipitation.

The young should be released beside the caged parents. When I put them into a small basket made from fresh branches outside the aviary, the owls free themselves by climbing out after a few minutes. Usually they spend their first night in a tree above the aviary in contact with the adult owls and brothers and sisters. A supply of known food is laid out daily within sight. The owls learn this place quickly. I will emphasize that offering food will not lead to dependence of the birds; they visit the feeding station only if they are unsuccessful in catching their own prey.

MONITORING

As long as the young owls utter begging calls, their position can easily be located. But just at the age of release the social family context breaks up and the offspring will disperse. I have not yet been able to develop an optimal technique to register systematically the daily locations of the birds. Owls found dead or observed incidentally give us hints on their fate.

Of 76 released birds, 10 were found dead (table 2). The lifespan of these owls has averaged only 6 months. This suggests that the mortality rate is highest at the end of winter, when body condition is at a minimum (extreme data: 46 days to 5 years). Most of the young owls disperse in autumn before snow cover decreases prey abundance. The average dispersal distance is 10.2 km (extreme data: 2 to 21km).

The recovery rate is surprisingly low (13%). This is on the one hand a fact of difficulty of survey in dense woodland, and on the other hand of unapproachable areas, especially in adjacent Czechoslovakia.

As the records of owls in the woodlands remained unsatisfactory, we have used radio transmitters from "Biotrack" (R. Kenward/GB), weighing 12g, working for 9-12 months and at a distance of 1-5km (fig. 5). As the "rucksack" package could affect the owl's prey-catching success, and the bird cannot get rid of the harness after the transmitter fails, we decided to mount radios on the quills of the middle tailfeathers. In this type of radio, the flexible antenna is fixed along the quills. This method has been demonstrated by Kenward (1978) with the

Tab. 2.-- Reintroduction of Ural Owl; release and recoveries (1973-1986).

release in 12 years	76	6,3 owls/year (extr.= 0-14)
found dead	10	13%
causes of death	3	starved
	2	fence
	1	traffic
	1	power line
habitat chosen	4	old mixed forest
	2	forest edge near meadow
distance of dispers.	Ø	10,2 kms (extr.= 2-20kms)
age of recoverie	Ø	6 months (extr.= 5 years)
telemetric equippm.		19 ex in 4 years



Figure 5.--Tail-mounted radio transmitter dropped after summer moult.

Goshawk, and we believe it would also be the safest technique for the Ural Owl, because the transmitter will drop with the tailfeathers during the yearly moulting. (Only 1 of 19 radio-marked owls pulled out the transmitter with its own tailfeathers, while entangled in a wire fence.)

We learned by telemetric techniques that the owls were very active during the first weeks after release. They flew 2-3km per day, also in bright daylight. After some weeks many of them had left the study area and we could no longer pick up their radio signals, especially when they went into Czechoslovakia. At the beginning of November the rest of the owls established home ranges in the national park, where they were frequently located, even after being absent for a few days.

When the daily locations are analysed to characterize habitat preference of *Strix uralensis* in this region, the pattern is: warm slopes with mixed stands of old woodland (spruce, fir, beech, maple; fig. 6). The owls use elevations of 750 - 1000m above sea level mostly. Proximity to meadows and clearings is conspicuous. Single



Figure 6.--Habitat preference shown by telemetric monitoring in the national park.

birds occupy surprising large areas. Maximum distance of individual locations was 12km for instance during early autumn dispersal, and almost 4km from an adult territorial female. It is an interesting fact that some owls re-occupied locations of former distribution in the Bohemian Forest, where the species was last recorded 50-60 years ago (Kucera, pers. comm.)!

In case the captive-bred owls could be imprinted to artificial nestboxes, I mounted 50 nestboxes of the same type as in the aviaries in suitable habitat. This could be another chance to raise the quality of monitoring, especially for breeding activity.

SUCCESS

Preliminary success of the reintroduction experiment can be sketched only in a rough way, as many released owls left the study area and only a few individuals provided good data. At least 5 individuals settled in the national park. Some home ranges were occupied over 5-10 years. Four clutches of two eggs each were found in the nest boxes (1983=1, 1985=2, 1986=1), but all the breeding was done by females without mates (fig. 7)!

Preliminary results indicate that males disperse over a larger distance than females (only 1 male was found to stay for over one full year), and that females can occupy a territory themselves, defending it by uttering territorial calls; they even start to breed there unpaired!

The main problems of this project can only be answered partly: a) It still is not possible to reconstruct causality of regional extinction: Was it caused by changes in forest harvesting? Did the shifting of climate from a continental to an atlantic type with more precipitation in 1920 - 1950 affect the birds? Was shooting a dominant factor? Was genetic isolation a problem in this local population when it separated from the main

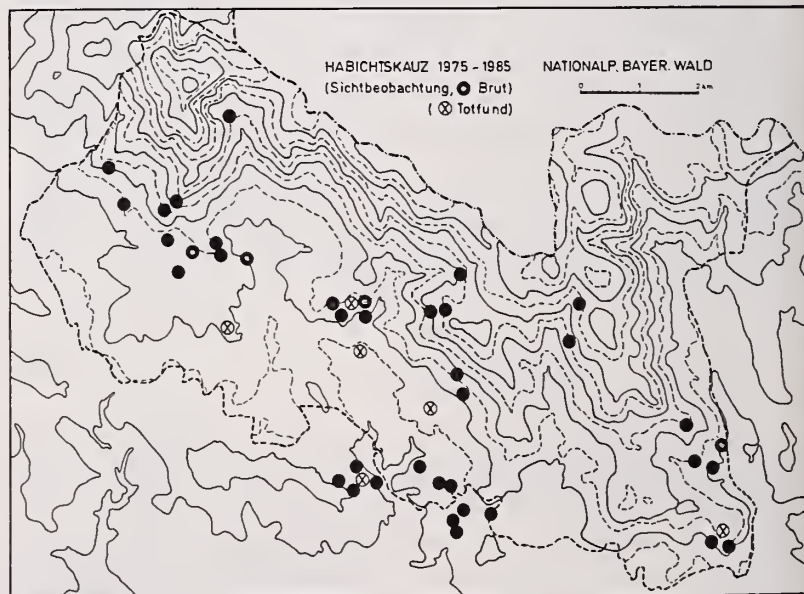

Figure 7.--Distribution of the Ural Owl in the national park, and locations of initiated broods.



Figure 8.--Natural forest is the objective of environmental development in the national park. Will this decrease habitat quality for the Ural Owl?

part in Eastern Europe? Was a separate, self-sustaining population established, or just a peripheral branch in the Bohemian Forest?

b) It is not possible to deduce data on former habitat characteristics from historical records. Until the beginning of the 20th century, for instance, heavy logging led to large clearcuts. In Scandinavian habitats the positive effect of large clearings in the forest is clearly shown for population trends of mice and Ural Owls. Today we try to reach quite the opposite objective through natural development of old, virgin woodland in the national park (fig. 8). The Ural Owl probably is dependent on open areas and cannot live in dense woods (?). Perhaps national park strategies will decrease quality of habitat in its woodland for this owl species.

c) The study area in the national park is 130km² and covers the montane and subalpine region of these mountains (about 700 - 1400m NN), for which heavy precipitation and long-lasting snow cover are characteristic (snow cover lasting from early November to April/May; depth of snow 80cm in the valleys and up to 250cm in the mountains). There the feeding situation will be adverse for birds of prey in winter. They probably migrate to lowlands with milder climate.

d) As far as we can conclude from breeding experiments in captivity, there is no genetic barrier against hybridization with *Strix aluco* as sibling species. This native owl species is common in the national park, with an abundance of 25 breeding pairs, on the average. Lacking a partner of its own species could stimulate the Ural Owl to choose the wrong mate!

Testing the risk of hybridization, I first reared Tawny Owls imprinted by Ural Owls as foster parents. When adult, such owls chose the foster species as social partners, but only birds from



Figure 9.--F1 hybrids of *Strix aluco* x *Strix uralensis*.

their own species as sexual partners, which they can recognize from the species-specific song. In contrast, normally reared Tawny and Ural Owls paired easily when lacking a partner of their own species. From this F1 brood, 3 hybrids were born; 1,1 young survived and the male was back-crossed successfully with Tawny and Ural Owls. The female showed full breeding behavior, but never laid an egg. Characteristics of plumage follow intermedial heredity (fig. 9), whereas voices are dominated by the Tawny Owl (matrocline? Scherzinger 1983). No records of hybrids exist from the field so far. The most important barrier for species isolation should be the specific voice, therefore.

e) The number of owls released annually was relatively small (6.3 owls per year). Consequently there was no realistic chance to get the area fully covered with good pairs.

f) There is a great risk of genetic isolation of the very small population which could be found in the national park. Following calculation of population genetics, a founder group of 20 specimens could be sufficient, but final abundance must rise to at least 500. Only 6 to 8 pairs of Ural Owl could be estimated to breed in the national park area. All the suitable habitats of Bohemian Forest, which lie in Bavaria, Austria, and Czechoslovakia, would be necessary to establish a stable population.

CONCLUSION

From preliminary experiments we can conclude that the Ural Owl can still exist in these mountains. Experienced individuals can survive

even under severe winter conditions, when there is heavy snow cover. In the future it will be necessary to release at least 15 - 20 individuals per year, probably from more wide-spread locations, to compensate for dispersal movements. Therefore we must create a larger breeding stock, either by enlarging the breeders association in cooperation with zoos and pet lovers, or by

enlarging our breeding station in the national park. This second way is very expensive and has been cancelled by our office this year. Therefore the resumption of reintroduction of the Ural Owl in the Bavarian Forest is at stake. The final decision will depend on results of an intensified monitoring project of radio-marked owls during the next years.

Mate and Nest-Site Fidelity in Ural and Tawny Owls¹

Pertti Saurola²

Abstract.--This study is based on Finnish ring recoveries and retraps. The data suggests that 98-100% of Ural Owl (*Strix uralensis*) males, 90-95% of the females, and 80-90% of both sexes of the Tawny Owl (*Strix aluco*) are faithful to their previous nest site. Fidelity to the mate seems to be almost absolute (95-97%) in the Ural Owl, but less (80-85%) in the Tawny Owl.

INTRODUCTION

Owls are very popular among the subjects for Finnish bird ringers. More than 12 500 nest-boxes for owls and 3500 natural holes are checked annually (Haapala and Saurola 1986), and more than 10 000 owls were ringed in 1986, the top year so far (table 1). This enthusiasm provides us with relevant data on the biology of owls.

Fidelity to the nest site and fidelity to the mate are life history characteristics which vary from species to species. In many studies on population ecology of a species (mortality studies, studies on life-time reproductive output etc.), knowledge about these strategies are of vital importance.

Although very little hard data have been published, it is more or less a dogma, that both the Ural Owl and the Tawny Owl are very faithful to their breeding sites, and that their pair-bond is life long (e.g. Mikkola 1983).

In this paper, I first describe the methods for capturing adults of these species at the nest and then discuss nest site and mate fidelity based on the Finnish ring recovery and retrap data.

¹Paper presented at the Northern Forest Owl Symposium. [Winnipeg, Manitoba, Canada, February 3-7, 1987].

²Pertti Saurola is the Head of Finnish Ringing Centre, University of Helsinki, Helsinki, Finland.

Table 1.--Ringing of owls in Finland in 1986, and grand totals 1913-1986.

	1986 pullus	1986 full- grown	1913-1986 total
Eagle Owl			
<i>Bubo bubo</i>	719	4	4760
Snowy Owl			
<i>Nyctea scandiaca</i>	-	-	14
Hawk Owl			
<i>Surnia ulula</i>	140	16	1246
Pygmy Owl			
<i>Glauc. passerinum</i>	45	63	919
Tawny Owl			
<i>Strix aluco</i>	1201	143	19383
Ural Owl			
<i>Strix uralensis</i>	1569	120	12067
Great Grey Owl			
<i>Strix nebulosa</i>	9	1	796
Long-eared Owl			
<i>Asio otus</i>	530	162	6391
Short-eared Owl			
<i>Asio flammeus</i>	231	13	3386
Tengmalm's Owl			
<i>Aegol. funereus</i>	4044	1797	36120
Total	8488	2319	85016

MATERIAL AND METHODS

Capturing Adults at the Nest

If the nest is in a nest-box or similar natural cavity, the females can usually be captured very easily. If the opening of the box/cavity is covered by a capacious butterfly net, the female either tries to escape and jumps into the net, or stays in the nest, from which she can readily be taken by hand.

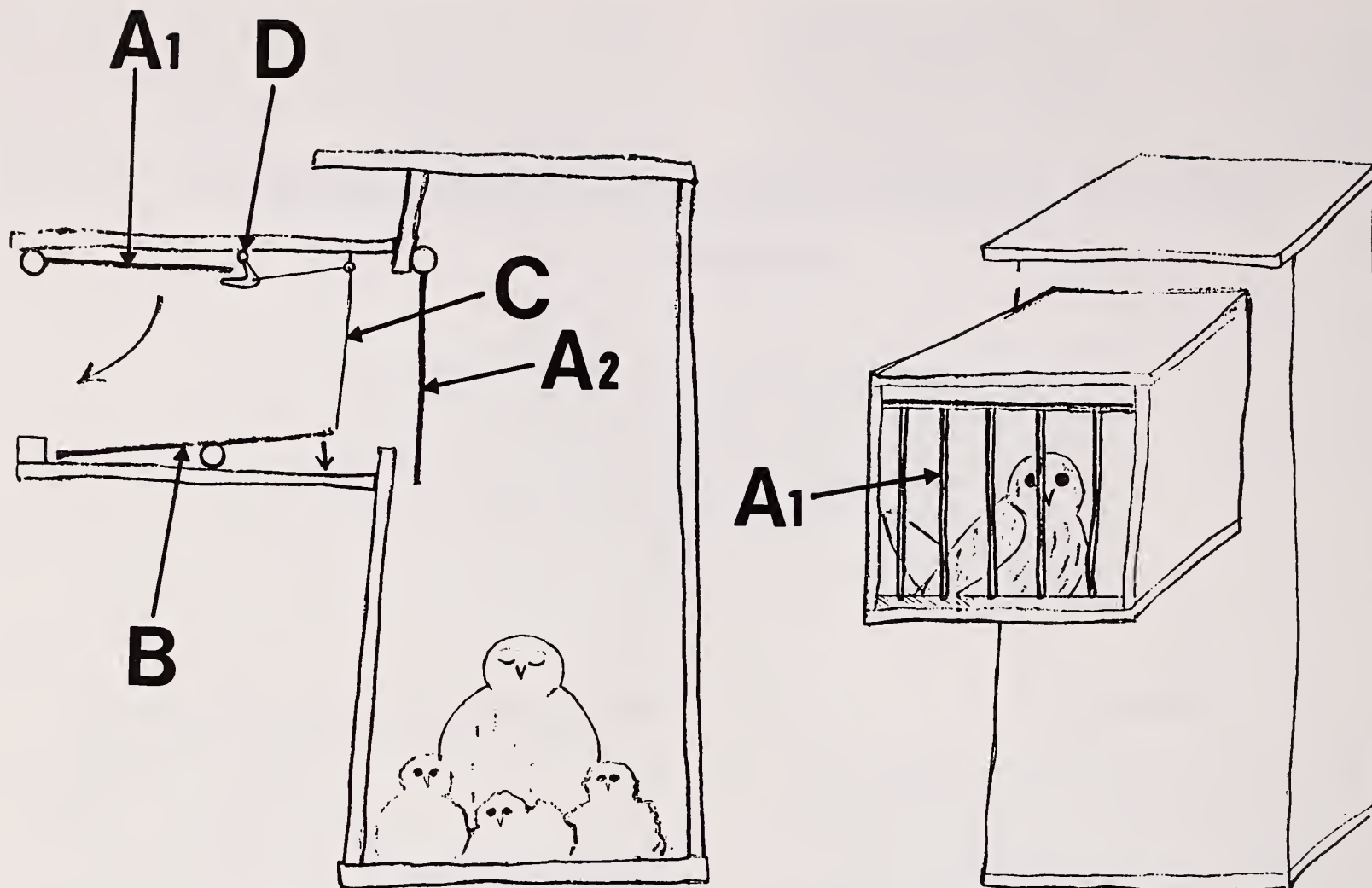

Figure 1.--A trap for capturing males. A1 and A2 are swing doors, made of vertical bars (horizontal bars cause injuries on the base of the bill), B is a swing board which is connected by a nylon line (C) to the releaser (D).

Ural Owls can safely be trapped during the whole period the female stays inside the nest-box, i.e. from the beginning of egg-laying through the first ten days of the nestling period. In contrast, Tawny Owl females should not be captured before the young are hatched, because this species is sensitive and is very likely to desert the nest if disturbed during the incubation.

Trapping of males is much more complicated and time consuming. I have used the following procedure. A couple of days after the young are hatched the female is shut in the nest-box and a trap for the male is attached to the front of the hole (fig. 1). In normal circumstances, the female answers, when the male hoots on returning with the prey. She flies out and receives the prey outside the nest-box. However, with the female shut in the nest-box, the male is forced to take the prey into the nest, and so enters, and is caught in the trap.

Almost all Tawny Owl males can readily be captured using this method. The Ural Owl

males are, in general, much more suspicious and some males are so difficult that more than one night (at 3-5 nights intervals) is needed to capture them. It is important that this extra disturbance is compensated for by giving extra food to the female and nestlings both before and after each trapping attempt.

Data Sets and Their Biases

Nest site fidelity is examined here on the basis of three kinds of data sets, which all are biased, but in different ways.

1) Data on owls captured at least in two breeding seasons at the nest in my study area ("Hauho", 61°10'N / 24°35'E, table 2). These data give reliable and comparable information, but only from a fairly small area: movements away from the study area can not be detected.

2) Data on owls captured during at least two breeding seasons at the nest over the whole of Finland (table 3). This data set gives more information on long distance

Table 2.--Maximum distances between two nest sites in sequence for each individual in the study area "Hauho".

Distance moved (km)	Number of birds			
	Ural Owl		Tawny Owl	
	male	female	male	female
0	47 (85%)	47 (60%)	21 (53%)	31 (61%)
1-5	8	28	18	18
6-10	-	3	1	-
11-15	-	-	-	2
Total	55	78	40	51

Table 3.--Maximum distances between two nest sites in sequence for each individual, total Finnish data. (Movements >30 km: Ural Owl female 160 km; Tawny Owl male 34 km, female 34, 40, 57, 58 and 68 km.)

Distance moved (km)	Number of birds			
	Ural Owl		Tawny Owl	
	male	female	male	female
0-5	55 (100%)	555 (96%)	109 (97%)	341 (90%)
6-10	-	17	2	15
11-20	-	3	-	15
21-30	-	-	-	3
>30	-	1	1	5
Total	55	576	112	379

movements, but because trapping-sites are patchily distributed and cover only a small part of Finland, the probability for a short distance retrap is higher than for a long distance one. Further, Ural Owl males have only been captured in my study area, and Tawny Owl males only in mine and two other study areas ("Valkeakoski", 61°15'N / 24°03'E by Pertti Nikkanen, and "Siuntio", 60°15'N / 24°15'E by Kimpari Bird Projects /Kari Ahola). Thus, only the females of both species have been caught extensively. Therefore this data is representative only for comparisons between the females.

3) Total Finnish data on owls captured at the nest and found dead at least 6 months later (table 4). The first weak point in this data set is, that if mortality among birds, which leave their territories because of a bad food situation, is higher than among those which stay, the probability for a long distance recovery is higher than for a short distance one. Further, because many of the Ural Owl nest sites are located in forests with a low level of human activities, the probability that a dead Ural Owl is found within it's territory may often be much lower than that it is found some kilometres away. The same

Table 4.--Distances moved by owls trapped at the nest and found dead >6 months later, total Finnish data. (Movements >30 km: Ural Owl female 97 and 219 km; Tawny Owl male 35, 37 and 57 km, female 34, 42, 45 and 89 km.)

Distance moved (km)	Number of birds			
	Ural Owl		Tawny Owl	
	male	female	male	female
0-5	10 (100%)	53 (85%)	28 (76%)	117 (76%)
6-10	-	3	3	17
11-20	-	2	1	10
21-30	-	2	2	6
>30	-	2	3	4
Total	10	62	37	154

problem does not emerge for the analysis of Tawny Owl recoveries, because this species is generally associated with areas of high human density throughout it's life.

RESULTS

Nest Site Fidelity

Fidelity to the breeding territory seems to be almost absolute in the Ural Owl male: so far all Ural Owl males have been encountered within a 5 km radius of the nest site used during the previous nesting attempt. However, the distance between two most remote nest sites of a Ural Owl male may be somewhat more than 5 km (see fig. 2). Ural Owl male differs significantly from the female and from both sexes of the Tawny Owl in nest site fidelity (table 2, comparison: no movement at all versus movement; $\chi^2 = 8.7$, $p < 0.01$).

For the Ural Owl female and the Tawny Owl, the estimate for fidelity to a nest site depends on the data set used. In a set of ordinary ringing recoveries (table 4), 85% of the Ural Owl females and 76% of both sexes of the Tawny Owl were reported from within 5 km from the last nest site, but the corresponding figures from the total retrap data (table 3) are 96%, (97%) and 90%. Both these sets of estimates are biased, in opposite directions (see Material and Methods).

According to all information from retraps, nest site fidelity of the female is significantly higher in the Ural Owl than in the Tawny Owl (table 3, comparison: movement < 5km versus movement >5km, $\chi^2 = 15.0$, $p < 0.001$), but the corresponding difference in ordinary ringing recoveries

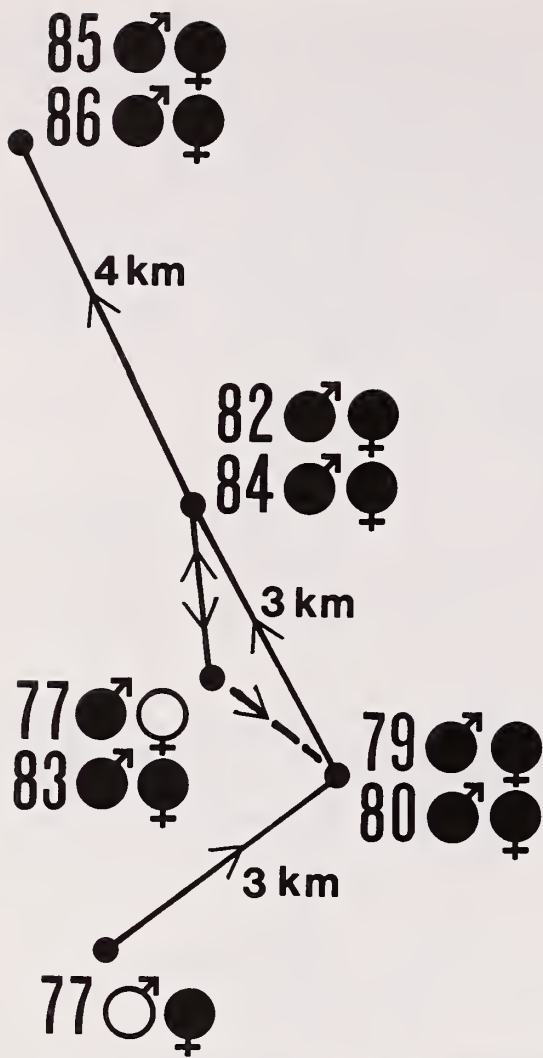

Figure 2.--Nest sites of a Ural Owl female and male (filled symbols) in 1977-1986.

is not significant (table 4; see Material and Methods for differences between the two species in recovery probabilities).

At the moment my best nest site fidelity estimates for the south Finnish populations are: 98-100% for the Ural Owl male, 90-95% for the female and 80-90% for the both sexes of the Tawny Owl.

Mate Fidelity

The example in fig. 3 shows clearly, that the pair-bond is not very strong in Finnish Tawny Owls. The average divorce rates (table 5) of 12% for the Tawny Owl and 3% for the Ural Owl must be understood as minimum values, because the probability of finding both members of a pair alive is very much higher, if they breed together at or near the previous nest site than if one (or both) has moved a longer distance.

My academic "guesstimates" for the real divorce rates are at the moment 15-20% for the Tawny Owl and 3-5% for the Ural Owl. None of the divorces in table 5 can,

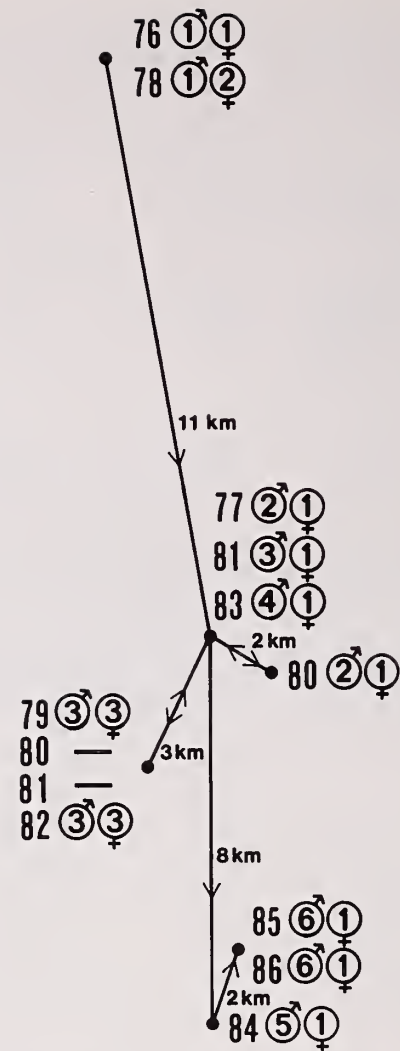

Figure 3.--Nest sites and mates of a Tawny Owl female in 1976-1986. The following divorces can be verified. 1) In 1977, female 1 moved away and paired with male 2; male 1 was found breeding with female 2 in 1978. 2) In 1981, female 1 paired with male 3, which left his territory and female 3. 3) In 1982, male 3 returned back to his previous territory and female 3; female 1 was found breeding in 1983 in the same nest box as in 1981.

in my opinion, be attributed to unsuccessful breeding in the previous year.

In the 17 cases of divorce (table 5), male and female Tawny Owls have left their original territory and mate with almost the same frequency: in 10 cases only the female moved, in 6 cases only the male and in 1 case both.

DISCUSSION

Is There a Latitudinal Trend in Site Fidelity in the Tawny Owl?

In Tengmalm's Owl *Aegolius funereus*, a latitudinal trend from more nest site tenacious populations in Central Europe to



Tawny Owls in Finland.

Photos by Pekka Helo



Table 5.--Divorce rates in the Tawny Owl and Ural Owl. N = number of cases, when both members of a pair were verified alive in a later breeding season, divorces= verified number of pairs separated. Hauho, Valkeakoski and Siuntio are study areas (see Material and Methods).

	N	divorces	divorce rate
Tawny Owl			
- Hauho	58	10	17.2
- Valkeakoski	42	1	2.3
- Siuntio	41	6	14.6
Total	141	17	12.1
Ural Owl			
- Hauho	113	3	2.7

the very nomadic ones in northern Fennoscandia has been described by Korpimäki et al. (1987). This trend in the reproductive tactics of the species has been attributed to the cyclicity in microtine populations which increases from south to north (see Hansson and Henttonen 1985).

Very little exact information, based on such techniques as radio-tracking or capture-recapture of breeding adults at the nest, has so far been published on the site fidelity of the Tawny Owl and Ural Owl. According to mostly indirect and scanty data available from Britain (Hirons 1985) and Central Europe (Delmée et al. 1978, Melde 1984), fidelity to the territory once selected seems to be almost absolute in both sexes of the Tawny Owl. Hence, there is presumably a real difference in the nest

site fidelity between Central European and Fennoscandian populations in this species, according to the data presented here.

In Tengmalm's Owl, the sexual differences in nest site fidelity have been seen primarily as a part of the reproductive tactics of the species: the females are more ready to change the breeding area than the males, which try to keep their nest hole, even in a cyclic environment, until the next favourable breeding season (Lundberg 1979). In the Tawny Owl, which is also a hole nesting species, no significant difference can be found in the nest site fidelity between the two sexes. For this reason, I suggest that the Tawny Owls, which have changed their territories, have moved primarily because of pressure to do with their winter survival rather than in search for a new and more favourable breeding area.

Why Is Nest Site Fidelity Stronger in Male than in Female Ural Owls?

The nest site fidelity of the Ural Owl has been postulated as being more or less absolute, partly on the basis of very scanty data and partly because of theoretical considerations (Lundberg 1979). The Ural Owl is a generalist feeder, which can survive even in severe winters, and breeds in suitable tree cavities, which are a scarce resource.

On the basis of my own data, there seems to be a relatively small but significant difference between the sexes. In the male the fidelity is absolute, but 5-10% (or even 15%) of the females leave their territories and can be found as much as 200 km or more away from their previous breed-

ing site. This difference can be explained in three different ways.

1) As a general difference in the breeding strategy of the two sexes, described for many different groups of birds (e.g. Greenwood and Harvey 1982) and including different responses to the death of the mate: the female can begin to search for a new mate and territory, but the male must guard his nest hole and wait for a new mate.

2) As an indication of higher readiness for nomadism (change of breeding area according to the food situation) in the female than in the male as was found in Tengmalm's Owl (Korpimäki et al 1987, see above).

3) As a consequence of the female's reduced ability, as the less skillful hunter of the two sexes, to survive a really hard winter famine.

At the moment none of the alternatives can be preferred on the basis of hard data. One very recent ring recovery (not included in table 4) suggests that at least some females have probably moved only because of famine: a female, which bred successfully for 10 years in the same territory, was found dying 70 km from her nest site in January 1987 during an exceptionally cold period after a crash of vole populations.

Does a Real Pair-Bond Exist in the Ural Owl and Tawny Owl?

In the literature (e.g. Mikkola 1983) both the Tawny Owl and Ural Owl are listed, without presenting any hard data, with the species whose pair-bond is life-long. Present data from Southern Finland indicates that annually at least 15-20% (or even more) of Tawny Owl pairs separate, but only 3-5% of the Ural Owls.

In some species, e.g. in the Kittiwake (Coulson and Thomas 1983) failure during the previous breeding season is probably the most important cause for divorce. On the other hand, Newton and Marquiss (1982) concluded, that the food situation is the only decisive factor for mate fidelity in the Sparrowhawk. This conclusion is probably valid also for the Tawny Owl and Ural Owl.

Is there any "real" pair-bond in the Tawny Owl and Ural Owl? Do members of a pair breed together, with the observed probability, only as a consequence of their relatively high nest site fidelity? For a reliable answer much more detailed information, including radio-tracking of several individuals is needed. At the moment I am ready to suggest, that the pair-bond in the Tawny Owl can be explained merely as fide-

lity of the both sexes to the nest site and breeding territory. In contrast, some of the Ural Owl pairs have moved together to new nest sites over such long distances (fig. 2), that any explanation which does not accept the existence of a real pair-bond in this species is difficult.

Acknowledgements. Kari Ahola (Kimpari Bird Projects) and Pertti Nikkanen put their original data at my disposal. Mika Kilpi and Chris Mead made valuable comments on the first draft of the manuscript. Jukka Haapala and Kirsi Hutri draw the figures.

LITERATURE CITED

- Coulson, J.C., and C.S. Thomas. 1983. Mate choice in the Kittiwake Gull. p. 361-376. In Bateson, P. (ed.), *Mate Choice*. Cambridge University Press, Great Britain.
- Delmée, E., Dachy, P., and P. Simon. 1978. Quinze années d'observations sur la reproduction d'une population forestière de Chouette hulottes (*Strix aluco*). *Le Gerfaut* 68:590-650.
- Greenwood, P.J., and P.H. Harvey. 1982. The natal and breeding dispersal of birds. *Ann. Rev. Ecol. Syst.* 13:1-21.
- Haapala, J., and P. Saurola. 1986. Breeding of raptors and owls in Finland in 1986 (in Finnish with English summary). *Lintumies* 21:258-267.
- Hansson, L., and H. Henttonen. 1985. Gradients in density variations of small rodents: the importance of latitude and snow cover. *Oecologia* (Berlin) 67:394-402.
- Hirons, C.J.M. 1985. The effects of territorial behaviour on the stability and dispersion of Tawny owl (*Strix aluco*) populations. *J. Zool., Lond.* (B) 1, 21-48.
- Korpimäki, E., Lagerström, M., and P. Saurola. 1987. Field evidence for nomadism in Tengmalm's Owl *Aegolius funereus*. *Ornis Scand.* 18:1-4.
- Lundberg, A. 1979. Residency, migration and a compromise: adaptations to nest-site scarcity and food specialization in three Fennoscandian owl species. *Oecologia* (Berlin) 41:273-281.
- Melde, M. 1984. *Der Waldkautz. Die Neue Brehm-Bucherei* 564. A. Ziemsen Verlag, DDR.
- Mikkola, H. 1983. *Owls of Europe*. T & A D Poyser, England.
- Newton, I., and M. Marquiss. 1982. Fidelity to breeding area and mate in Sparrowhawks *Accipiter nisus*. *J. Anim. Ecol.* 51:327-341.

Nest Platforms for Great Gray Owls¹

Evelyn L. Bull,² Mark G. Henjum,³
and Ralph G. Anderson⁴

Abstract.--During 1983-1986, 12 great gray owl (*Strix nebulosa*) pairs nested on artificial platforms in northeastern Oregon. Platforms put up 15 m were preferred over those platforms put up 9 m. Nest platforms were preferred over nest boxes. Each platform cost \$40 to construct and mount.

The loss of natural nest sites has encouraged use of artificial nest structures for owls (*Strix* spp.) in northern Europe (Stefansson 1978, Rauhala 1980, Hilden and Helo 1981, Mikkola 1983, Helo 1984), and Canada (Nero 1980). In the Pacific Northwest, great gray owls (*S. nebulosa*) frequently nest in vacated hawk nests or on the broken tops of dead trees. Intensified timber management has reduced the number of available nest sites because many large diameter dead and live trees have been harvested.

At least 5 types of nest structures have been constructed for and used by great gray owls. Helo (1984) described an open nest structure 40 x 30 cm with a height of 10 cm that great gray owls have used. Nest structures used in Canada and Minnesota include wire frames with sticks inside (Nero et al. 1974, Nero 1982), wire baskets with sticks inside (Bohm 1985), and nests constructed of sticks alone (R. W. Nero, pers. comm.). Quinton (1984) described nests created by cutting the tops off trees and making a shallow depression inside the bole.

Great gray owls readily use artificial structures (fig. 1); we wanted to determine if the owls had a preference for height of nest (placed at 9 m or 15 m above the ground), type of nest (wooden platforms or nest boxes), and

distance of nest from a clearcut (adjacent to a clearcut or 100 to 200 m from the edge of a clearcut).



Figure 1. Female great gray owl nesting on wooden platform in northeastern Oregon, 1986.

METHODS

We established 3 study areas in the Blue and Wallowa Mountains in northeastern Oregon where mixed conifer forests were interspersed with openings. In study area A, we selected 26 sites and put 2 platforms (fig. 2) at each site, in separate trees but within 30 m of each other. One platform was 9 m and the other was 15 m above the ground.

In study area B, we selected 27 sites near clearcuts created 1 to 10 years ago. At each site, 1 platform was adjacent to the clearcut

¹Paper presented at the Northern Forest Owl Symposium, Winnipeg, Manitoba, February 3-7, 1987.

²Research Wildlife Biologist, Forestry and Range Sciences Laboratory, La Grande, OR.

³Wildlife Biologist, Oregon Department of Fish and Wildlife, La Grande, OR.

⁴Biological Technician, Wallowa Valley Ranger Station, Joseph, OR.

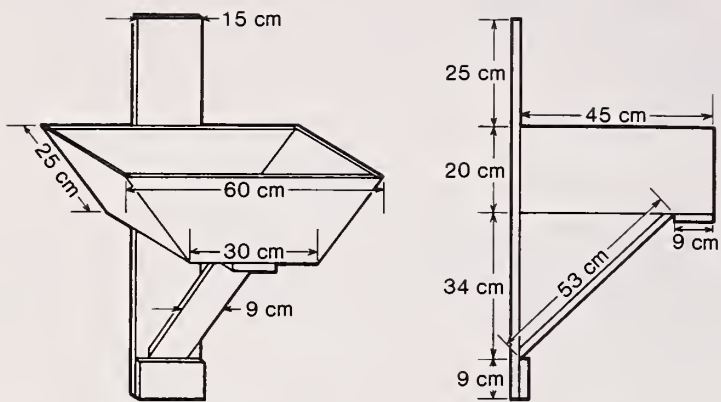

Figure 2.--Great gray owl nest platform constructed from 2-cm thick boards. Holes were drilled for 20-cm long ring-shank nails used with washers. Platforms were stained with 5 parts linseed oil and 1 part gray stain.

and 1 in a forest stand 100 to 200 m from the edge of the clearcut. Platforms were put 9 m above the ground.

In study area C, we selected 26 sites and put 1 wooden platform and 1 wooden nest box (fig. 3) at each site. Each platform was within 30 m of a box, and both were 9 m above the ground. An additional 28 wooden platforms were erected in study area C between 1975 and 1985 but were not part of this study. The platforms, 9 m above the ground in forested stands, were checked irregularly over the years.

Sites were at least 0.5 km apart--the minimum distance we found between active nests of great gray owls. Sites for platforms were selected based on historic use by great gray owls and the presence of mature trees.

Platforms were placed on the northeastern side of live trees _ 30 cm dbh (diameter at breast height) to reduce solar heat. Branches were removed along the bole from the ground to 1 m above the platform to allow access by the birds. An 8-cm layer of chips was placed in the bottom of platforms and boxes with twigs 1 cm in diameter placed on top. This chip layer permitted birds to dig depressions in which to lay eggs. Holes (1 cm in diameter) were drilled in the bottom of platforms and boxes for drainage.

The nest structures were put up in September 1984 in study areas A and B, and in summer 1982 in study area C. Each structure was checked annually in late April because great gray owls usually started incubating in late March. The female's tail was usually visible over the edge of the nest structure.

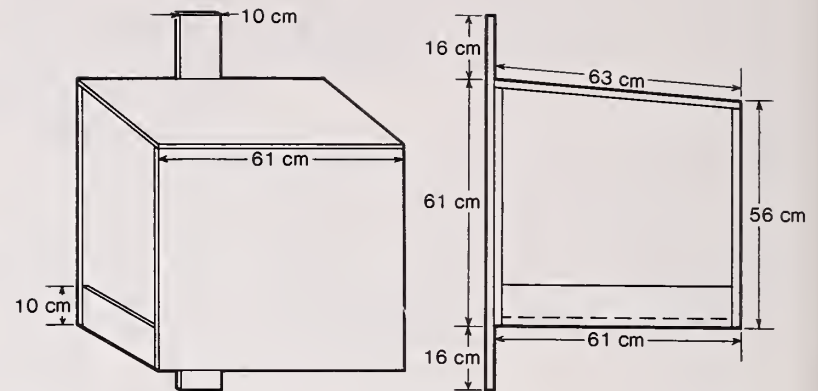

Figure 3.--Great gray owl nest box constructed of 1-cm thick plywood. The vertical support piece was a 2 x 10 cm board. Holes were drilled for 20-cm long ring-shank nails used with washers. Platforms were stained with 5 parts linseed oil and 1 part brown stain.

The cost of constructing and mounting the platforms was calculated using \$5 for materials/platform, \$7/hr for labor, and \$0.10/km for vehicular travel. Eight platforms could be erected in a 10-hr day. To construct and mount, each platform cost \$40.

RESULTS

From 1983 to 1986, 12 great gray owl pairs nested on these platforms (table 1). All 5 pairs that nested on platforms in study area A used the platforms 15 m above the ground. Two pairs nested in study area B, 1 on a platform adjacent to a clearcut and 1 on a platform 200 m from a clearcut. All 5 pairs that nested in study area C used wooden platforms. None used nest boxes. Ten of the 12 nesting pairs successfully fledged young. At least 5 of the additional 28 platforms in study area C were used by nesting great gray owls during 1980-1986.

Great horned owls (*Bubo virginianus*) nested on 1 platform in 1985 and on 5 platforms in 1986.

DISCUSSION

Great gray owls preferred the wooden platforms to the boxes and preferred the 15-m to the 9-m height, although the 9-m height was used when other suitable platforms were not available (as in study areas B and C). Platforms adjacent to and 200 m from a clearcut were used. Great gray owls sometimes used wooden platforms when natural nest sites were available nearby.

Table 1.--Number of artificial platforms used by great gray owls for nesting in northeastern Oregon, 1983-1986.

Study area	Year			
	1983	1984	1985	1986
A-Nest height (26 sites)				
9 m	NA ¹	NA	0	0
15 m	NA	NA	2	3
B-Proximity to clearcut (27 sites)				
Adjacent	NA	NA	0	1
100-200 m away	NA	NA	0	1
C-Nest structure type (27 sites)				
Platform	1	1	1	2
Box	0	0	0	0

¹Platforms not put up until September 1984.

The number of pairs that fledged young was higher for those pairs that nested on wooden platforms (83%) than for pairs that nested on stick nests, mistletoe clumps, or broken-topped dead trees (70%) (unpublished data, E. L. Bull). This higher success was partly because the platforms are stable; eggs or nestlings sometimes fell through stick and mistletoe nests.

A potential problem exists with great horned owls using the platforms because great horned owls are a major predator of fledged great gray owls (Nero 1980). We did not anticipate this problem because the great horned owl nests we had observed before 1984 were in more concealed sites than the ones we offered. Because great horned owls nest 1 to 3 weeks earlier and are more aggressive, they could successfully compete with great gray owls for nest sites on platforms. The subsequent increase in great horned owls could take its toll on fledged great gray owls in the area.

Mikkola (1982, 1983) addressed a similar problem installing artificial nest structures for the tawny (*S. aluco*) and ural owls (*S. uralensis*) in Europe. The tawny and ural owls prey on smaller owls, and in areas where artificial nest structures were used by tawny or ural owls, the smaller owls disappeared (Schonn 1980).

Thus, nest platforms can provide nest sites for great gray owls, but caution is needed because platforms could also increase populations of great horned owls, which could be detrimental to great gray owls. Given the rarity of great gray owls and the attraction the species has to segments of the public, the cost of providing artificial nest platforms is justified.

ACKNOWLEDGMENTS

R. A. Grove, J. S. Henderson, J. E. Hohmann, and M. E. Walker helped design, construct, mount, and check platforms. A. Franklin, W. I. Haight, H. Mikkola, R. W. Nero, Oregon Department of Fish and Wildlife, and personnel at the Wallowa Valley Ranger District provided additional assistance.

LITERATURE CITED

Bohm, R. T. 1985. Use of artificial nests by great gray owls, great horned owls, and red-tailed hawks in northeastern Minnesota. *Loon* 57:150-151.

- Helo, P. 1984. Yon Linnut, Kirja Suomen polloista. Kainuun Sanomain Kirjaitain Oy. 240 p.
- Hilden, O., and P. Helo. 1981. The great gray owl Strix nebulosa--a bird of the northern taiga. *Ornis Fennica* 58:159-166.
- Mikkola, H. 1982. Ecological relationships in European owls. Publ. of the Univ. of Kuopio. Natural Sciences Ser. Orig. reports 6/1982:1-157.
- Mikkola, H. 1983. Owls of Europe. Buteo Books, Vermillion, S.D.
- Nero, R. W. 1980. The great gray owl phantom of the northern forest. Smithsonian Institution Press, Washington, D. C. 167 p.
- Nero, R. W. 1982. Building nests for great gray owls. *Sialia* 4:41-80.
- Nero, R. W., S. G. Sealy, and H. R. Copeland. 1974. Great gray owls occupy artificial nest. *Loon* 46:161-165.
- Quinton, M. S. 1984. Life of a forest hunter--the great gray owl. *National Geographic*. July 1984:123-136.
- Rauhala, P. 1980. Kemin-Tornion seudeun linnusto. *Pohjolan Sanomat*, Kemi.
- Stefansson, O. 1978. Lappuggla (Strix nebulosa) i Norrbotten 1975-78. *Norrbottens Natur* 34:49-63.
- Schonn, S. 1980. Kauze als Feinde anderer Kauzarten und Nisthilfen fur hohlenbrutende Eulen. *Der Falke* 27:294-299.

Biology of the Great Gray Owl in Interior Alaska¹

Timothy O. Osborne²

Abstract.--The great gray owl was found frequently in the Yukon and Koyukuk River lowlands from 1981 to 1984 in successional white spruce forest. The owls occupied winter roosts which were habitually used in successive years. Yellow-cheeked vole (*Microtus xanthognathus*) composed 66%, by frequency, of the diet, other microtines composed 28%, and other mammalian and avian prey composed 6%.

INTRODUCTION

The status of the great gray owl (*Strix nebulosa*) in Alaska is thought to be scarce or rare (Armstrong 1980); however, Gabrielson and Lincoln (1957) said the bird was found regularly but was by no means common. Brandt (1943) said it was "common in the heavily wooded bottomlands" and Dall and Bannister (1869) took eight specimens 20 miles east of Nulato in 1867-1868. Studies in Manitoba (Nero et al. 1984), Saskatchewan (Harris 1984), Idaho (A. Franklin pers. commun.) and Alaska (present study) have found that the bird can be found with predictable regularity once the habitat requirements are defined. In Alaska, from at least 1981 to 1984, the great gray owl was at a population peak which contributed to my ease in finding the birds. These "population highs" have been previously noted in Europe (Mikkola 1973) and Manitoba (Nero et al. 1984). It is of interest that the 1981-1984 population high I recorded appeared to also occur in the Manitoba-Minnesota region (R. Nero pers. commun.).

STUDY AREA AND METHODS

My study was conducted in the floodplain areas adjacent to the confluence of the Yukon and Koyukuk Rivers. The majority of the data was collected from an 82 km² area located 5 km east of Bishop Rock (64°49'N, 157°22'W), on the islands and north bank of the Yukon River (fig. 1). Bishop Rock is located 24 km downriver from Galena and 35 km northeast of Nulato. The floodplain, varying from 10 to 25 km wide, is the product of extensive meanders of the Yukon

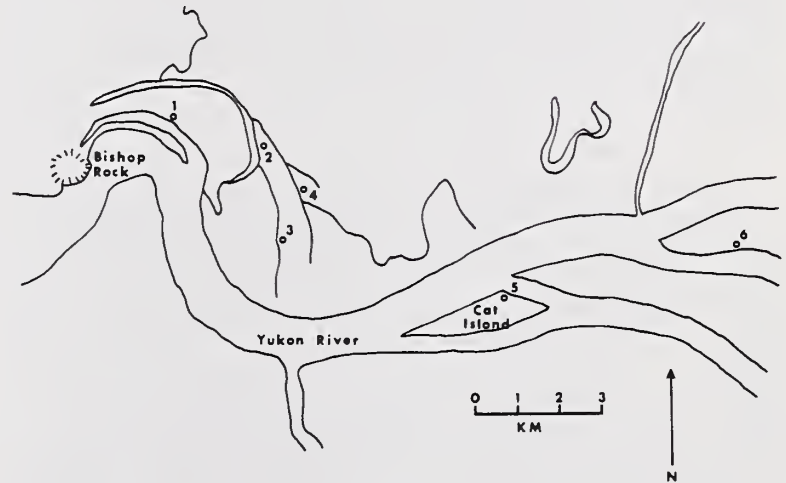

Figure 1.--Bishop Rock study area. Location of great gray owl nests (o) in 1984.

River over thousands of years. Away from the main channel are old levees with varying stages of succession ranging from willow (*Salix* spp.) dominated communities through balsam poplar (*Populus balsamifera*) stands to white spruce (*Picea glauca*) dominated communities. Adjacent to the old levees are oxbow lakes also in varying stages of succession from open water through reed grass (*Calamagrostis* sp.) meadows to willow/alder (*Salix* sp./*Alnus* sp.) meadows. In some areas these levees and oxbow remnants form concentric habitat bands. Interspersed are blocks of land with extensive permafrost layers close to the surface which only support an open community of stunted larch (*Larix laricina*), black spruce (*Picea mariana*), and bog-associated shrubs.

Climate in the area is continental subarctic characterized by great seasonal extremes of temperature ranging from -55°C to 33°C and daylight ranging from 3.5 h to 21.5 h. Ice is present from early October to late May, and average yearly snowfall is about 137 cm (Selkregg 1976). Flooding of low-lying areas is infrequent and can be caused by two different events: ice

¹Paper presented at the symposium, Biology and Conservation of Northern Forest Owls, Feb. 3-7, 1987, Winnipeg, Manitoba. USDA Forest Service General Technical Report RM-142.

²Timothy O. Osborne, P.O. Box 155, Galena, Alaska 99741.

jam floods or high-water floods. During winter 1984-1985, deep snow up to 2 m in the Yukon and Tanana River drainages produced a high-water flood which inundated many of the old oxbow areas for up to three weeks.

Data on the owls were collected opportunistically during studies of moose (*Alces alces*). Observations were conducted at irregular intervals from January 1982 to February 1987; however, most data were collected during winter and spring months. Nest trees were climbed, if possible, and contents recorded. At nest sites, prey remains and pellets were collected. At winter roosts, pellets were collected monthly by digging through the snow and after snowmelt in June. At one site a 1.5 x 1.5 m pellet collector was constructed using a 2 x 4 wooden frame covered with plastic sheeting forming a funnel. A plastic bucket with water drain holes was placed below the funnel throat to catch the pellets. The pellet collection device was abandoned after black bears (*Ursus americanus*) ate the plastic components. Pellets were dissected, and I identified prey remains by skull and tooth characters using voucher specimens from the University of Alaska Museum.

Three small mammal traplines were run along the Yukon River during late August 1984 and 1985 to ascertain relative prey densities. Each trapline had 20 stations 17 m apart, with two Museum Special snap traps baited with peanut butter and one pitfall funnel trap at each station. Each line was run for three consecutive nights. One line was in a permafrost bog/open black spruce community running perpendicular to the river, one line was in a mature balsam poplar stand running parallel to the river and the third site was 1 km from the river in a (*Calamagrostis* sp.) meadow. In 1985 the meadow site was covered with 0.5 m of water for 19 days during June, prior to trapping.

During intensive aerial moose surveys, I occasionally observed great gray owls either perched on meadow edges or as they flushed from tree roosts. The surveys were conducted using a Super Cub aircraft flying at 112 kmph at 100 m above ground level with a minimum ground search intensity of 4 min/mi². The observations produced a relative index of abundance which was biased due to varying sightability of the owls and their individual reactions to aircraft (some would flush and some would not). Sixteen surveys were flown in November and one in April. Data were used from the following moose trend areas: Kaiyuh Slough near Nulato; Squirrel Creek near Koyukuk; Three Day Slough (65°29'N, 157°30'W); Deep Creek 20 km NW Ruby; and Nowitna/Sulatna Rivers confluence (64°36'N, 154°28'W). Another method used to determine density was vocalizations by the owls, either during certain daylight periods or at night. I usually would initiate calling by imitating the owl's call and then listening for responses and calculating their positions.

RESULTS

The great gray owl occurred in successional white spruce lowland forests along the Yukon River. The meadows of grasses and sedges provided habitat for voles (*Microtus* spp.), were open hunting areas, and were fringed with willows and balsam poplars which provided hunting perches. Decadent balsam poplar and white spruce provided nesting sites. The area also had large breeding populations of common raven (*Corvus corax*) and red-tailed hawks (*Buteo jamaicensis*), which provided potential nest platforms. Mature spruce stands provided sheltered winter roost sites.

During the winter months, October to March, owls were found during daylight periods perched on the edge of open areas, such as meadows, creeks, sloughs, or along the main rivers. During the breeding season, April to July, the owls were always perched at or near the nest site. I was unable to observe owls while they were hunting during this period. I rarely observed owls once fledging occurred until winter conditions allowed access to the areas away from the river.

I was unable to ascertain if the owls were residents in the area or migrants, but since my sightings were mainly in the winter months, I suspect the birds were residents. I do not believe the breeding population was augmented by birds from other areas.

Nesting

The study area had no man-made nesting structures, thus the density of owls was dependent upon natural regulatory factors. Great gray owls do not build nests and are limited to available nest sites (Nero 1982). If there are sufficient nest sites, then other factors, such as food supply, regulate the population. Along the Yukon River, I found raven nests approximately every 1.5 km and decayed balsam poplar stumps, similar to those used for nesting, occurred very frequently. I found six owl nests in the 82 km² study area during 1984. The nests averaged 2.8 km apart (range 0.6 to 5.2 km). The density of breeding owls I found (fig. 1) was probably a minimum since it was impossible to search the entire Bishop Rock area. During nocturnal owl calling sessions, at least two more owls were calling adjacent to the area to the north. Owls, presumably breeding, were also seen on the south bank of the Yukon River. In the Three Day Slough area, during an overcast day in late March 1984, six different owls were calling in a 78 km² area. Mikkola (1981) noted that in Finland, calling during the day had never been reported.

I found a great gray owl nest on 5 June 1983 when it held two 300-400 g chicks. It was in an old raven nest near an area where I had seen owls in spring 1982. In March the nest had owl feathers and pellets on top of the snow-covered structure. On 24 June the nest was empty and the young were gone.

In 1984 I located 15 old raven nests in the area between Bishop Rock and Galena. The 1983 nest had signs of visitation, since the snow was "tramped" down, but no owls were seen at the nest by 14 April. On 15 April, I flushed a female great gray owl from a 4 m high balsam poplar stump (fig. 1, no. 3). She immediately returned to the stump and behaved as though she was incubating eggs. A male was perched nearby. On 19 April I checked all the old raven nests and likely stumps everywhere I had previously seen owls perched. I found five more occupied great gray owl nests. Three were in old raven nests (fig. 1, nos. 1, 5, 6), one was in a balsam poplar stump (fig. 1, no. 3), and one was in a white spruce stump (fig. 1, no. 4). Five of the nests were in balsam poplar woodland and one nest was in a white spruce-birch (*Betula* spp.) woodland. Only three of the nests were in trees I was able to climb. By 28 April two nests had a clutch of four and one had a clutch of five eggs. Four pairs produced three young each and two nesting attempts failed. I think two of the 1984 nest sites (nos. 3, 4) were active during the 1983 nesting season based on old pellets found under the leaf litter in 1984.

In 1985 owls were rarely seen during the winter. I checked all the previous nests and no eggs had been laid by the end of March. I checked the six old nests on 27 May and found two with incubating females (nos. 1, 3). One nest had two eggs on 5 June. On 22 June this nest had one dead 77 g chick and one live 150 g chick. The dead chick had an empty stomach and no fat reserves, which indicated that it died of starvation. On 5 July both nests had one young each. The very late laying dates, compared with 1984, may have been caused by the deep snow conditions. A. Franklin (pers. commun.) noted a three-week delay in mean egg-laying dates in Idaho following deep winter snow conditions.

In 1986 the nest sites were checked once in early May and none of the nests were active.

Roosts

In May 1982 I found a collection of owl pellets on the ground below a white spruce tree. There were numerous feathers of great gray owls scattered around and in the branches of the tree. Some of the pellets were on top of dried leaves, having been deposited during the previous winter; others were under the leaves and buried in the moss, indicating that they were deposited during or prior to leaf-drop in 1981. The roost was located on a levee area in a dense stand of white spruce, but only 20 m from an open slough. Although I never observed an owl at the roost, I suspect that the roost was used at night and during periods of cold weather, but verification was not possible since the roost could not be approached undetected and it was not safe to travel during weather colder than -40°C. The bird or birds mainly used the one tree, but some alternate roost trees were found. The main roost was in use each winter up to December 1984, at

which time it was abandoned. I did not check on the roost during winter 1985-1986, but the roost was in use again during December 1986. In other areas, more groups of pellets below spruce trees were found, indicating other habitual roosts. Habitual winter roosts have not been previously recorded for the species (R. Nero pers. commun., Mikkola 1981).

Diet

The information on diet of the great gray owl in Alaska is scant. They are said to eat "mice and other small mammals and birds" (Gabrielson and Lincoln 1957) and "mice and ground squirrels" (Armstrong 1980). In my study area, of 411 prey items, microtine rodents composed 94% (table 1). Other mammals and birds composed only 6% of the diet. Pellets (n=99) were collected from one nest in 1983, five nests in 1984, and two nests in 1985. At nest sites voles were the main prey items, but species composition was different at winter roosts (table 1). Yellow-cheeked voles (*Microtus xanthognathus*) was the most important prey item (76.8%) during the winter months, but dropped to half (48.1%) during summer. Results of a χ^2 test of these differences in seasonal preference are significant at the 0.01 level. The average number of microtines per pellet (n=114) was greater during winter (2.13 individuals/pellet) than during summer (1.28 individuals/pellet). The smaller number of individuals during summer may have been due partially to pellets from nestling birds being included in the sample.

The slight increase in the number of birds (table 1) in summer is probably due to the greater number of birds present in the habitat compared with winter.

DISCUSSION

The reference by Armstrong (1980) to great gray owls eating ground squirrels (*Citellus parryii*) is probably an error and his source cannot be found (R. Armstrong pers. commun.).

Table 1.--Great gray owl prey analysis from winter roosts and nests, Yukon River, Alaska, 1982-1985.

Species	Winter roosts		Nests	
	number	%	number	%
Mammals				
<i>Microtus xanthognathus</i>	196	76.8	75	48.1
<i>Microtus pennsylvanicus</i>	22	8.6	52	33.3
<i>Microtus oeconomus</i>	4	1.6	2	1.3
<i>Microtus</i> spp.	--	--	4	2.6
<i>Clethrionomys rutilus</i>	23	9.0	8	5.2
<i>Syaptomys borealis</i>	4	1.6	3	1.9
<i>Sorex</i> spp.	1	0.4	--	--
<i>Mustela erminea</i>	1	0.4	--	--
<i>Lepus americanus</i>	--	--	1	0.6
Birds				
Grouse	2	0.8	1	0.6
<i>Perisoreus canadensis</i>	--	--	1	0.6
Passerine bird	--	--	1	0.6
Unidentified feathers	2	0.8	8	5.2
Totals	255	100.0	156	99.9

The habitat of the ground squirrel (dry tundra) and the owl do not overlap. I never recorded the abundant and much more likely red squirrel (Tamiasciurus hudsonicus) in the owl's diet.

At nest sites, the meadow vole (Microtus pennsylvanicus) was only recorded in 1984 and 1985 which suggests that either meadow vole populations were low or the feeding area of the 1983 nest was not occupied by the vole. I suspect the vole population may have been low. At the roost, meadow voles composed only 4% of 124 microtines caught during 1982 and 1983, but 13% of 115 voles during 1984.

The results from the small mammal trapline indicated that the great gray owl was a selective predator. Shrews were abundant in the area in all habitats (table 2), composing 39% of the total animals caught, yet only one individual was found in the pellets (table 1). Mikkola (1981) compared the fall and winter diet of owls from Finland, Sweden, Canada, and USA and found the frequency of insectivores was 48.7, 21.5, 23.5, and 12.5%, respectively. However, in Finland the winter prey items may have been biased because they were from stomach contents of road-killed owls during years of low vole populations.

All great gray owl nests in California have been in broken off stumps (A. Franklin pers. commun.), in southern Oregon they used old goshawk (Accipiter gentilis) nests³, in Idaho they utilized a 58:42 ratio of stumps and old raptor nests (A. Franklin pers. commun.), and in Canada all the nests were in old raptor nests or man-made raptor-like nests (Nero 1980). All previous owl nests in Alaska had been found in old raptor nests, almost all in old goshawk nests (D. G. Roseneau pers. commun.; Alaska Department of Fish and Game raptor records; Gabrielson and Lincoln 1957). There appeared to be a clinal behavior of the owls tending toward old raptor nests in the north and stumps in the south. The introduction of man-made nest platforms clouds the trend. Mikkola (1981) found a similar cline in Finland. He found the owl nesting more frequently in stumps in the south and almost all the nests in the north were in old goshawk nests. The reasons for the tendency to use raptor nests in the north may be related to the decrease in tree size and circumference in northern latitudes. Logging practices and frequent fires in Canada may reduce the number of suitable stumps.

I concentrated my efforts in searching for old hawk and raven nests. Goshawks were occasionally seen in the study area, but for nesting they prefer hillsides with aspen (Populus tremuloides) or paper birch (Betula papyrifera). Seven red-tailed hawk nests were located in the area

³Forsman, E. D. and T. Bryan. 1984. Distribution, abundance and habitat of Great Gray Owls in southcentral Oregon. Rep. to Dep. Fish and Wildlife, Bend, Oregon, 30 June 1984.

Table 2.--Numbers of small mammals caught in three habitats during August, 1984 and 1985, Yukon River Alaska. Results from 90 trap-nights/habitat/year.

Species	Open black spruce		Balsam poplar		Grass meadow	
	1984	1985	1984	1985	1984	1985
<u>Microtus xanthognathus</u>	0	0	0	2	11	0
<u>Microtus pennsylvanicus</u>	0	1	0	0	1	19
<u>Clethrionomys rutilus</u>	7	21	35	33	3	0
<u>Syaptomys borealis</u>	0	0	0	0	1	0
<u>Sorex cinereus</u>	20	4	24	1	20	4
<u>Sorex hoyi</u>	0	2	0	1	0	1
<u>Sorex tundrensis</u>	0	0	1	2	0	0
<u>Sorex</u> spp.	2	0	3	1	0	1
Totals	29	28	63	40	36	25

and none were used by the owls for nesting. Perhaps the reason red-tailed hawk nests were not used may be because they build their nests closer to the top of the canopy. Thus their nests may expose the owls to harassment of passing raptors, or the young may be more subject to heat stress from the sun. All the nests selected by great gray owls were within the canopy of the tree or stand. Both ravens and goshawks build their nests below the canopy, usually at a level which is 2/3 the height of the tree. Of the nine nesting attempts, the owls used old raven nests five times and stumps four times. The use of stumps for nest sites in Alaska has not previously been recorded.

I believe that the owl population was high from the beginning of my study, although the breeding data I collected may indicate that the owl population increased from 1981 to a peak in 1984. The apparent increase was due to my increased familiarity which enabled me to find more pairs. The owl population in Alaska has probably undergone fluctuations in the past. This would account for the discrepancies in its status as reported earlier (Dall and Bannister 1869, Brandt 1943, Gabrielson and Lincoln 1957). The exact location where Dall (Dall and Bannister 1869) collected his owls is unknown. He reported the site as Takatisky, 20 miles east of Nulato. The location of Takatisky is attributed to the Kaiyuh Hills (Orth 1971); however, Zagoskin (Michael 1967) used the name "Takayaska" for both the Kaiyuh Hills and a settlement at the confluence of the Yukon and Koyukuk Rivers. If the location was 20 miles due east of Nulato, as reported by Dall, then the Bishop Rock study area is only 5 km north of where Dall collected his data.

I observed a decline in the breeding population of the owls over the period 1984-1986. The relative abundance of the owls observed

Table 3.--Aerial sightings of great gray owls during moose surveys, Middle Yukon River area, Alaska.

Year	1982	1983	1984	1985	1986
Owls observed	9	3	4	1	0
km ² surveyed	799	543	606	484	216
Relative density birds/km ²	1/89	1/181	1/151	1/484	0/216

during winter moose surveys also declined from 1984 to 1986 (table 3). I attributed the decline to the abnormally deep snow during winter 1984-1985 and a consequent reduction in food supplies (voles) following the 1985 flood of the meadows. After the flood, the vole species composition of the grass meadow changed from yellow-cheeked vole (*Microtus xanthognathus*) to meadow vole (*M. pennsylvanicus*) and the total numbers were reduced (table 2). Yellow-cheeked voles are dominant over other *Microtus* species in Alaska, and their presence in an area would tend to lower populations of the other voles (Wolff and Lidicker 1980). Presumably after the flood, meadow voles were able to recolonize the meadow faster than yellow-cheeked voles. Yellow-cheeked voles are very active diurnal voles and are the largest vole in Alaska, with males averaging 120 g (Wolff and Lidicker 1980). Deep snow during winter could have impaired owl hunting efficiency which caused them to emigrate from the area, winter roosts were abandoned, and owl hunting plunge-marks in the snow were only infrequently observed.

The presence of great gray owl hunting plunge-marks (see Nero 1980 for photographs) could be used as an indicator of owl habitat use, prey densities, and owl densities. As a method, its advantage is that owls do not have to be directly observed to detect their activities. I realized the value of using plunge-marks to indicate owl habitat use and density during December 1984. The snow was falling frequently and deep enough to make plunge counts a useful method; however, when I visited the area in January 1985 no owls were using the area and thus the method remains untested here.

ACKNOWLEDGMENTS

I would like to thank the following people for their assistance: R. Armstrong, E. Bull, A. Loranger, D. Gibson, G. Jarrel, J. Marcotte, S. McDonald, R. Nero, C. Nuckols, B. L. Osborne, L. Y. Osborne, and W. Winter.

LITERATURE CITED

- Armstrong, R. H. 1980. A guide to the birds of Alaska. Alaska Northwest Publ. Co., Anchorage, Alaska.
- Brandt, H. 1943. Alaska Bird Trails. The Bird Research Foundation. Cleveland, Ohio.
- Dall, W. H. and H. M. Bannister. 1869. List of the birds of Alaska, with biographical notes. Transactions of Chicago Academy Sciences, 1, pt 2, pp 267-310.
- Gabrielson, I. N. and F. C. Lincoln. 1957. The birds of Alaska. Stackpole, Harrisburg, Pennsylvania.
- Harris, W.C. 1984. Great Gray Owl in Saskatchewan (1974-1983). Blue Jay 42:152-160.
- Michael, H. N., ed. 1967. Lieutenant Zagoskin's travels in Russian America 1842-1844. Univ. of Toronto Press, Toronto.
- Mikkola, H. 1973. In Burton, J.A., ed. Owls of the World. Peter Lowe, Weert, Netherlands.
- Mikkola, H. 1981. Der Bartkauz. A. Ziemsen Verlag, WittenbergLutherstadt, GDR.
- Nero, R. W. 1980. The Great Gray Owl: phantom of the northern forest. Smithsonian Institution Press, Washington, D.C.
- Nero, R. W. 1982. Building nests for Great Gray Owls. Sialia 4(2):43-48.
- Nero, R. W., H. W. R. Copland, and J. Mezibroski. 1984. The Great Gray Owl in Manitoba, 1963-1983. Blue Jay 42:130-151.
- Orth, D. J. 1971. Dictionary of Alaska Place Names. U.S. Gov. Printing Off., Washington, D.C.
- Selkregg, L. L., ed. 1976. Alaska regional profiles Yukon region. Univ. of Alaska, Fairbanks, Arctic Environ. Info. Data Center, Anchorage, Alaska, Vol 1.
- Wolff, J. O. and W. Z. Lidicker. 1980. Population ecology of the taiga vole, *Microtus xanthognathus*, in interior Alaska. Can. J. Zool. 58:1800-1812.

A Floristic Analysis of Great Gray Owl Habitat in Aitkin County, Minnesota¹

Mark F. Spreyer²

Abstract -- The floristic community associated with fourteen Great Gray Owl (*Strix nebulosa*) nest sites (Loch, in lit.) was analyzed. The overstory was dominated by black ash (*Fraxinus nigra*) and basswood (*Tilia americana*) and the prevalent shrub layer species included currants (*Ribes sp.*) and silky dogwood (*Cornus amomum*). Ginger (*Asarum canadense*), bedstraw (*Galium sp.*), wild strawberry (*Fragaria virginiana*), and jewelweed (*Impatiens capensis*) were common in the ground layer. Most of the nest sites were of the *Cornus Carex sp.-Caltha palustris* habitat type according to Mueller-Dombois (1974). Conversion of this habitat type for farming or mining poses a long-term threat to Great Gray Owl habitat in Aitkin County.

INTRODUCTION

The objective of this study was to describe the nest site habitat of the Great Gray Owl in Aitkin County, Minnesota. The effects of land use practices on the owl's habitat will be discussed.

SITE DESCRIPTION AND METHODS

Site Description

The Aitkin County study area, approximately 20 square miles in area, is located in north central Minnesota. Elevations within the study area range from 1235-1266 feet above sea level. The January mean temperature is approximately 4 F., the July mean temperature is about 66 F., and the mean annual precipitation is approximately 26 inches (Clapp, 1981).

The area is a mix of tamarack-black spruce (~50%), open communities composed of grass and sedge meadows or other open situations (~30%), and hardwood communities (~20%). The soils are predominantly organic in nature.

METHODS

A 400 square meter plot, 20 meters on a side, was centered on each nest tree. The plot size is a modification of the recommended tenth-acre circular plots (James and Shugart, 1970; Titus and Mosher, 1981). All trees over five meters in height (Mueller-Dombois and Ellenberg, 1974) were measured for diameter at breast height with a diameter tape and for height with a Spiegel-Relaskop. Each tree was rated as to its position in the canopy (Smith, 1962). The nest tree and three other dominant or codominant trees were drilled with an increment borer to determine age. At four locations in the plot, per cent cover was determined using a densiometer.

For this study the shrub layer was defined as plants, generally woody perennials, ranging in height from 50 centimeters to 5 meters (Mueller-Dombois and Ellenberg, 1974). The average height, cover (Daubenmire, 1968), and dispersion (Braun-Blanquet, 1965) will be recorded for each shrub species within the 400 square meter plot. The plot was transected four times in order to describe the understory.

The ground layer was defined as plants, usually herbaceous, that are less than 50 centimeters in height (Mueller-Dombois and Ellenberg, 1974). Two smaller plots, measuring 2 meters by 1 meter and located in a regularized pattern within the larger plot, were used to study the herbaceous layer. Each species' cover and dispersion were ocularly estimated using the same scales applied to the shrub layer.

¹ Paper presented at the symposium, Biology and Conservation of Northern Forest Owls, Feb. 3-7, 1987, Winnipeg, Manitoba. USDA Forest Service General Technical Report RM-142.

² St. Cloud State University, St. Cloud, Minnesota
Present Address: Chicago Academy of Sciences
Chicago, Illinois 60614

In addition to conventional soil information, a soil scientist from the U.S. Soil Survey visited some of the nest sites and contributed to the habitat analysis. Plant and soil data were combined to classify the habitat in accordance with a "Key for Mapping Forest Habitat Types in Southeast Manitoba. . . ." (Mueller-Dombois, 1974).

RESULTS

Nest tree and site data are summarized in table 1. All but two of the nest trees, whose tops had recently been damaged, were in dominant positions in the canopy. Twelve of the fourteen nest trees were hardwood species. Also, all except one nest tree was taller than the average height for the plot. Nine sites had less than 10% cover, twelve sites had less than 30% cover and all fourteen sites had less than 45% cover.

The nest sites as well as the nest trees were dominated by hardwood species especially black ash (*Fraxinus nigra*) basswood (*Tilia americana*), american elm (*Ulmus americana*), red maple (*Acer rubrum*), and sugar maple (*Acer saccharum*) (see table 2). In the shrub layer black ash, *Ribes sp.*, hazel (*Corylus cornuta*), silky dogwood (*Cornus amomum*), and american elm were the most common species (see table 3). Ginger (*Asarum canadense*), bedstraw (*Galium sp.*), wild strawberry (*Fragaria virginiana*), canada mayflower (*Maianthemum canadense*), sarsaparilla (*Aralia nudicaulis*), violets (*Viola sp.*), jewelweed (*Impatiens capensis*), and species of sedge (*Carex sp.*) were the most common species in the ground layer (see table 4).

According to material supplied by the Soil Conservation Service, over three quarters of the soils in the twenty square

mile study were formed in organic materials. Twelve of the fourteen nest sites, however, were on soils formed in glacial till. These mineral soil series (see table 1) are generally poorly drained fine sandy loams that are either thinly covered by or include pockets of organic soil. Eight of the twelve mineral soil sites are Alstad loam. The two nest sites on organic soils are both Cathro muck. Standing water can be found on almost all the soils in the study area particularly after rains and during spring run-off.

Not surprisingly, the Mueller-Dombois (1974) key to forest habitat types characterize all of the nest sites as "Habitats with excessive soil moisture." Twelve sites are a flood water association described as the *Cornus-Carex sp.-Caltha palustris* type (ew). *Fraxinus sp.* and *Larix laricina* are often found growing in the ew type (see table 1). The other two sites are on a bog type described as the *Betula pumila-Carex-Caltha-Potentilla* type (BC). *Larix laricina* is the most common tree found growing in this habitat.

DISCUSSION

Great Gray Owls do not construct or maintain the nests they occupy (Nero, 1980) and, as mentioned earlier, much of their habitat is dominated by a tamarack swamp system. The small size and pyramidal form of the trees provides fewer suitable nest locations than would a similar stand of large, irregular shaped hardwoods. It should come as no surprise then that most natural nests were found in dominant hardwood trees. In the study area, hardwood species were almost always associated with mineral soils.

Similarly, the correlation between the poorly drained soils and the presence of plants such as american elm,

Table 1. NEST TREE AND SITE DATA

	<u>Nest Sites</u>						
	A	B	C	D	E	F	G
Nest type	natural	natural	artificial	art.	nat.	nat.	nat.\art. ¹
Years used	1979	'79&'80	1979	'79&'80	1979	1979	1980
Nest Tree species	A. Elm	Larch	P. Birch	B. Ash	Y. Birch	B. Ash	B. Popular
N. T. canopy position	dominant	dom.	dom.	dom.	intermediate ²	dom.	dom.
N. T. age (years)	61	n/a ³	55	95	98	97	65
N. T. height (meters)	18.5	14	20	20.5	16.5	15.5	26.5
Average age of trees (years)	58.5	55.7	52.5	99.3	69.5	74.8	60.5
Average height of trees (m.)	11.4	10.3	12.8	13.6	15.7	8.5	12.6
Canopy cover (%)	6.5	43.5	5.75	19.5	9.0	39.75	5.75
Soil series	Cathro	Cathro	Shooker	Talmoon	Alstad	Alstad	Shooker
Habitat type	BC	BC	ew	ew	ew	ew	ew
	I	J	K	L	M	N	O
Nest type	nat.	nat.	nat.	art.	nat.	nat.	art.
Years used	1980	1980	1980	1980	1980	1980	1982
Nest Tree species	S. Maple	B. Popular	S. Maple	Basswood	Basswood	P. Birch	Larch
N. T. canopy position	dom.	dom.	dom.	dom.	dom.	overtopped ²	dom.
N. T. age (years)	83	72	87	72	68	n/a ³	125
N. T. height (meters)	21	25	19	24	17	5.5	13.5
Average age of trees (years)	80.5	68.25	75.8	62.3	60	66.7	122.2
Average height of trees (m.)	16.3	15.2	17.1	12.5	12.9	9.1	11.9
Canopy cover (%)	8	3	21.5	6.5	.86	3.75	27
Soil series	Alstad	Alstad	Alstad	Alstad	Alstad	Alstad	Talmoon
Habitat type	ew	ew	ew	ew	ew	ew	ew

¹ It was a natural nest in 1980. By 1982, an artificial nest was put in its place.

² These trees had lost their tops due to storm or wind damage.

³ These trees were too rotten to age with an increment borer.

Table 2. BASAL AREA FOR TREES (m²/ha)

Species	A	B	C	D	E	F	G	I	J	K	L	M	N	O	Total/species
<i>Abies balsamea</i>					.5		.2		3.5			.6	10.6		15.4
<i>Acer rubrum</i>	1.8		1.8					4.6	.8		4.3	13.1			26.2
<i>A. saccharum</i>								23.2		9.5	.1	.9			33.7
<i>A. spicatum</i>													.4		.4
<i>Betula alleghaniensis</i>					3.4				7.9	7.3	1.3		6.7		26.8
<i>B. papyrifera</i>			5.7						1.2		1.2	.2	5.2		13.5
<i>Carpinus caroliniana</i>											.2				.2
<i>Fraxinus nigra</i>	6.8		1.0	16.2	24.1	5.6	13.4	.3	1.0	1.4	.2	4.1	1.0		75.1
<i>Larix laricina</i>		12.2												14.3	28.3
<i>Ostrya virginiana</i>										2.8	.8		1.4	.1	5.1
<i>Picea mariana</i>		.4													.4
<i>Populus balsamifera</i>							17.7		.7						18.4
<i>P. tremuloides</i>			1.9				.9								2.8
<i>Quercus macrocarpa</i>			2.6			2.0	1.1				.2	.2	.2		6.3
<i>Sorbus americana</i>		.1													.1
<i>Thuja occidentalis</i>				1.6					16.1						17.7
<i>Tilia americana</i>			9.3		.5		.8	7.7		16.6	20.4	4.7			60.0
<i>Ulmus americana</i>	9.0		4.6	9.1	2.1		5.8								30.0
Total/site	17.4	12.7	28.9	26.9	30.6	7.6	39.5	35.8	31.2	37.6	28.7	23.8	28.7	14.4	

Table 3. SHRUB LAYER COMPOSITION (Cover/Dispersion)

Species	Nest Sites															
	A	B	C	D	E	F	G	I	J	K	L	M	N	O		
<i>Abies balsamea</i>							1/1									
<i>Acer rubrum</i>	3/1		1/1			1/1	1/1					1/1				
<i>A. saccharum</i>								3/1		3/1	1/1					
<i>A. spicatum</i>							1/1		3/1	2/1	2/1		3/2			
<i>Actaea pachypoda</i>									1/1	1/1		1/1				
<i>A. rubra</i>									1/1	1/1		1/1				
<i>Alnus rugosa</i>		3/2				1/2										
<i>Amelanchier sp.</i>					1/1											
<i>Aralia racemosa</i>								1/1		1/1	1/1					
<i>Betula papyrifera</i>						1/1										
<i>B. pumila</i>		2/2												2/2		
<i>Cornus alternifolia</i>								1/1								
<i>C. amomum</i>	1/1	1/2	1/1	1/1		1/1								1/1		
<i>C. rugosa</i>					1/1											
<i>Corylus cornuta</i>			4/2		1/1		5/2		1/1	2/1	2/2	1/1				
<i>Fraxinus nigra</i>	1/1		1/1	1/1	1/1	1/1	1/1	1/1	1/1	1/1	1/1	1/1	1/1			
<i>Ilex verticillata</i>	2/2														1/1	
<i>Larix laricina</i>	1/1	1/1													1/1	
<i>Ledum groenlandicum</i>															1/1	
<i>Lonicera canadensis</i>									1/1							
<i>Ostrya virginiana</i>								1/1					1/1			
<i>Picea mariana</i>															1/1	
<i>Populus balsamifera</i>									1/1							
<i>P. tremuloides</i>			1/1			1/1	1/1					1/1				
<i>Prunus virginiana</i>			1/1	1/1			1/1		1/1		1/1					
<i>Quercus macrocarpa</i>			1/1			1/1	1/1				1/1	1/1		1/2		
<i>Ribes sp.</i>	1/1		1/1	1/1	1/1	1/1		1/1		1/1						
<i>Rosa sp.</i>															1/1	
<i>Rubus sp.</i>					1/1	2/3		1/1							2/2	
<i>Salix sp.</i>		1/2				2/2					1/1		1/1			
<i>Sambucus pubens</i>											1/1					
<i>Spiraea alba</i>	1/1	1/2									1/2					
<i>Tilia americana</i>			1/1				1/1	1/1	1/1			1/1				
<i>Ulmus americana</i>			1/1	1/1	1/1	1/1	1/1	1/1								
<i>Vaccinium sp.</i>						2/3										
<i>Zizia aurea</i>					1/1											

The Daubenmire Cover Scale

Cover Class	Range of Cover (%)
6	95-100
5	75-95
4	50-75
3	25-50
2	5-25
1	0-5

Braun-Blanquet Degrees of Dispersion

- 5 = growing in large, almost pure population stands
- 4 = growing in small colonies or forming larger carpets
- 3 = forming small patches or cushions
- 2 = forming clumps or dense groups
- 1 = growing solitarily

(Table 4. Cont.)

Rubus hispidus				1/1																
R. idaeus	3/4			1/1			1/1		1/1		1/1	1/1	1/1	1/1	1/1	1/1	1/1	1/1	1/1	1/1
Sanicula sp.		1/1					1/1		1/1											1/1
Scirpus sp.							1/1													1/1
Solidago sp.				1/1		1/1														1/1
Sphagnum sp.	5/5	3/4																		4/4
Spirea alba	1/1																			1/1
Stellaria longifolia									1/1		1/1	1/1	1/1							1/1
Streptopus roseus				1/1					1/1											1/1
Taraxacum officinale																				1/1
Thalictrum dioicum																				1/1
Thelypteris palustris		1/1	1/1																	1/1
Tiarella cordifolia																				1/1
Toxicodendron radicans																				1/1
Trientalis borealis																				1/1
Trillium grandiflorum				1/1																1/1
Ulmus americana																				1/1
Uvularia perfoliata																				1/1
Viola cucullata																				1/1
V. papilionacea																				1/1
Viola sp.		1/1																		1/1
Zizia aurea	1/1	1/1																		1/1

black ash, silky dogwood, jewelweed, and bedstraw that favor wet sites is to be expected. Other plants such as hazel, canada mayflower, basswood, and sugar maple indicate a more mesic site (Coffman, Alyanak, and Resovsky, 1980). The Soil Conservation Service information confirms this site characterization. The abundance of wild strawberry suggests that much of the area has been disturbed (Coffman, Alyanak, and Resovsky, 1980). Old homesteads and logging operations in the area could account for the presence of strawberry. Present land use practices, as well, continue to disturb this area and adjacent regions in Aitkin County.

Plotting the nest sites on an air photo suggests a correlation between nest location and man-made openings such as power line right-of-ways, wildlife openings, and dirt roads. This is probably just a coincidence. The power company, road builders, and wildlife managers logically chose mineral soils in which to plant their poles and on which to drive their equipment. Unfortunately, the local loggers also seem interested in mineral soils since they support more valuable species of trees. Two nest sites that were to be included in this study were excluded since they had recently been logged.

If trees with nest structures were left alone or if artificial nests were erected, small scale logging in the area would probably have little impact on the owl's habitat. Information provided by the Soil Conservation Service provides a clue to a more serious threat to Great Gray Owl habitat. "This soil is well suited to grow cultivated farm crops if excess ground water is adequately drained." Developers in Aitkin County, acting on similar recommendations and economic considerations, have drastically altered thousands of acres in order to grow potatoes. The effects of scraping, ditching, and tiling are much more significant than that of logging. Then, of course, there is always the prospect of peat mining.

This study indicates the importance of mineral soils and stands of hardwoods to the nesting efforts of Great Gray Owls. This is, however, only one aspect of the bird's habitat. How much sedge meadow, tamarack swamp, or other cover type does it need for hunting? How critical is the availability of nest sites? Of course, more comprehensive raptor habitat studies have been conducted (Titus and Mosher, 1981). These studies were on birds who build their own nests and who both hunt and nest in similar habitats. New methods of investigation will have to be developed to adequately answer

questions about Great Gray Owl habitat.

Ideally, a habitat suitability index model should be constructed for the species. Such a model could be used to identify and protect appropriate owl habitat. I hope the information contained in this paper would prove useful in the construction of a habitat model for the Great Gray Owl. Until a more comprehensive study is conducted, forest cover type maps and soil surveys could be combined to find areas of high value to Great Gray Owls.

LITERATURE CITED

- Braun-Blanquet, J. 1965. *Plant Sociology: The Study of Plant Communities*. (Transl. rev. and ed. by G. D. Fuller and H. S. Conrad.) Hafner, London. 439 p.
- Coffman, Michael S., Edward Alyanak and Richard Resovsky. 1980. *Habitat Classification System Field Guide for Upper Peninsula of Michigan and Northeast Wisconsin*. Developed by Cooperative Research on Forest Soils.
- Clapp, T. W. 1981. *Climate in Minnesota*. Unpublished, St. Cloud State University. 1 p.
- Daubenmire, R. F. 1968. *Plant Communities: A Textbook of Plant Synecology*. Harper & Row, New York. 300 p.
- James, F. C. and H. H. Shugart, Jr. 1970. A quantitative method of habitat description. *Audubon Field Notes* 24: 727-736.
- Mueller-Dombois, D. and H. Ellenberg. 1974. *Aims and Methods of Vegetation Ecology*. John Wiley & Sons, New York. 547 p.
- Nero, Robert W. 1980. *The Great Gray Owl*. Smithsonian Institution Press, Washington, D.C. 167 p.
- Smith, D. M. 1962. *The Practice of Silviculture*. John Wiley & Sons, New York. 578 p.
- Titus, K. and J. A. Mosher. 1981. Nest-site habitat selected by woodland hawks in the central appalachians. *Auk* 98: 270-281.

Movement Strategies, Mortality, and Behavior of Radio-Marked Great Gray Owls in Southeastern Manitoba and Northern Minnesota¹

James R. Duncan²

Abstract.--Forty-three great gray owls (*Strix nebulosa*) were radio-marked in southeastern Manitoba and northern Minnesota. The movements and behavior of these birds revealed sex-biased mobility in a year of low prey availability and residency in a high microtene year. The great horned owl (*Bubo virginianus*) was the most significant predator in both situations. The adaptive significance of different life-strategies evolved in the great gray owl are discussed.

INTRODUCTION

Natural selection has operated on northern forest owls to produce numerous adaptations enabling their survival in boreal forest habitat. These include anatomical (i.e., wing shape and size) and behavioral (i.e., hunting methods) adaptations resulting from interactions with prey populations over an evolutionary time scale (Norberg 1987)¹. Mikkola (1983) noted a large degree of niche overlap among many northern forest owl species. He speculates that this lack of ecological isolation is due to the cyclic nature of their food and that, during years of low prey densities, the local sympatry of owls is not constant. Observable morphological and behavioral differences have arisen from interspecific competition and in response to a number of environmental constraints. Lundberg (1979) notes that nest-sites, food, clutch size, mate and nest territory fidelity, sexual dimorphism and longevity all help shape the pattern of mobility and wintering strategies of northern forest owls. Of these, food abundance and nest-site availability are considered the most prominent (Lundberg 1979, Nero 1980, Mikkola 1983) and are thought to interact as follows:

a) There should be selection for year-round residency of both sexes in hole-nesting (scarce resource) food generalists.
e.g. ural owl, *Strix uralensis*: (Lundberg 1979; Saurola 1987¹).

¹Paper presented at the symposium, Biology and Conservation of Northern Forest Owls, Feb. 3-7, 1987, Winnipeg, Manitoba. USDA Forest Service General Technical Report RM-142.

²James R. Duncan is a Ph. D. candidate, McGill University, Montreal, Quebec.

e.g. barred owl, *Strix varia*: ¹(Nicholls & Fuller 1987).

b) Both sexes should be migratory if nest-sites are abundant but a dependence exists on a highly fluctuating food source (voles).
e.g. long-eared owl, *Asio otus*: (Lundberg 1979).

c) In hole-nesting food specialists, resident males and migratory females should be selected for.
e.g. boreal owl, *Aegolius funereus*: (Lundberg 1979, Korpimäki 1986a).
northern hawk-owl, *Surnia ulula*: (Byrkjedal & Langhelle 1986; Sonerud 1986).

Lundberg (1979) concluded that assured access to a nest-site is probably the most fundamental factor governing movement patterns in northern forest owls. Therefore, the ural and barred owls residency is presumably an adaptation to the scarce nature of their nesting structure and is facilitated by their generalistic diet. The relative abundance of stick nests allows the long-eared owl to migrate to snow-free areas, and is required because of its specialized small mammal diet. A conflict arises between migration (specialist diet) and residency (scarce suitable nest-holes) for the boreal and northern hawk-owls. Here, males should remain resident for as long as possible and females should move to areas of greater prey densities or vulnerability (Lundberg 1979). Sonerud (1986) stated that the above arguments can be reversed whereby the nesting site is determined by a) feeding ecology, b) hunting habitat, and c) the effect of snow cover on prey vulnerability.

While all owls can hunt by the energetically inexpensive sit-and-wait mode, some, like the long-eared owl, use the energetically more expensive quartering (flying) hunting method. During snow-free periods both hunting methods can take advantage of prey occurring in clear-cuts

and similar openings. Sonerud (1986) determined that because of snow cover the less abundant small mammal populations occurring in forest habitat are more vulnerable to predation than the more abundant populations occurring in open areas. This is due to increased supra-nivean and snow-tunneling activity of small mammals in the former habitat resulting from the lack of a well developed, continuous, pukak layer (space formed at the snow-ground interface). Short and broad wings, providing greater maneuverability among vegetation, are but one of many adaptations enabling certain forest owls to capture prey in wooded habitat (Norberg 1987)¹. The relatively long and narrow wings of the long-eared owl renders it less able to capture prey in forest habitat. It must migrate to snow-free areas and return only when open areas are partially snow-free. By this time presumably only old stick nests are available. Long-eared owls will use nest-holes (nest boxes) on rare occasions when competitors are absent (Cave 1968 in Sonerud 1986). Ural and barred owls can remain year-round residents by their ability to locate and capture prey by the sit-and-wait hunting mode in forest habitat. Their year-round residency is facilitated by their ability to survive on alternate prey items when small mammal populations are at a cyclic low. Northern hawk-owls and boreal owls also employ a sit-and-wait hunting strategy, enabling them to reside year-round in forest habitat where the small mammals on which they specialize are more vulnerable during periods of snow cover. However, during periods of low small mammal densities, they are less able to switch to alternate prey than are ural and barred owls. Observed male residency of northern hawk-owls and boreal owls perhaps indicates that the potential reproductive benefits of possessing a suitable nest structure outweigh the risk of winter starvation (Lundberg 1979).

The great gray owl (*Strix nebulosa*) is quite catholic in its use of habitat and nest structures, but it is a small mammal specialist and is therefore similar to the long-eared owl (Collins 1980, Nero 1980, Mikkola 1983, Roselar 1985 and Korpimaki 1986b). According to Lundberg (1979) it should be migratory, but Sonerud (1986) argues that given adequate prey it should exhibit year-round residency since, like the boreal and northern hawk-owls, it can hunt within forest habitat and catch concealed prey. However, normal microtine populations can decline to extremely low densities at unpredictable intervals, and can subsequently fail to recover for long periods of time (Mihok et al. 1985). During such declines we may predict age and sex biased mobility as was reported for northern hawk-owls by Byrkjedal & Langhelle (1986). These predictions arise from three "single-factor" hypotheses reviewed by Ketterson & Nolan (1983) and discussed in Byrkjedal & Langhelle (1986).

a) Body Size Hypothesis: larger birds endure fasting better than smaller ones and therefore are in less need of migrating (which may imply a mortality risk).

b) Dominance Hypothesis: subdominant birds are relegated to adverse habitats due to intraspecific competition and are the first to move when conditions get harder.

c) Arrival-time Hypothesis: the sex that establishes the breeding territory should migrate the shortest distance in order to get early access to a territory in spring.

In this paper I shall examine the movements and behavior of radio-marked great gray owls in relation to the above hypotheses and compare those of other northern forest owl species. The adaptive nature of the different life-strategies evolved in these species will be discussed.

MATERIALS AND METHODS

1. Radio-telemetry

Forty-three great gray owls were radio-marked in southeastern Manitoba and northern Minnesota between April 1984 and August 1986. This area is primarily boreal forest. Two locations, A & B (fig. 1), approximately 100km apart, are currently being experimentally managed for this species in light of existing and potential threats to habitat. Both locations contain large stands of old and mixed-age growth tamarack (*Larix laricina*) and tamarack/black spruce (*Picea mariana*) with natural and man-made openings, i.e., burns and clear-cuts. The owls radio-marked within the study area, all of figure 1, may be described as three samples:

a) April-July 1984: eight mated pairs, a breeding male, and 11 of their progeny. Radio-marked at location A, figure 1 (Loch 1985)³.

b) February-March 1986: three immature (hatch-year 1985) males, two adult females, and an adult male. Radio-marked at various locations within the study area, figure 1.

c) June-August 1986: a breeding pair, two breeding females, and five of their progeny. Radio-marked at location B, figure 1.

Radio-transmitters measured 8cm long by 15cm in diameter and averaged 35g complete with harness. A 28cm long whip antenna extended posteriorly from each unit. Each transmitter was powered by a 2000 milliamper, 3.9 volt lithium battery; current drain ranged from 0.10-0.19 milliamper/hour. Frequencies were separated by at least 15khz within the 164 megahertz band. A modified "back-pack-type" harness, consisting of a plastic coated wire running through 6mm (diameter) of teflon tubing, was developed by Loch (1985)³ to attach transmitters to owls. Properly fitted, the transmitter and harness

³Loch, S. L. 1985. Manitoba great gray owl project progress report. April 1, 1984 to August 1, 1985. Manitoba Dept. of Nat. Res., Winnipeg, Manitoba.

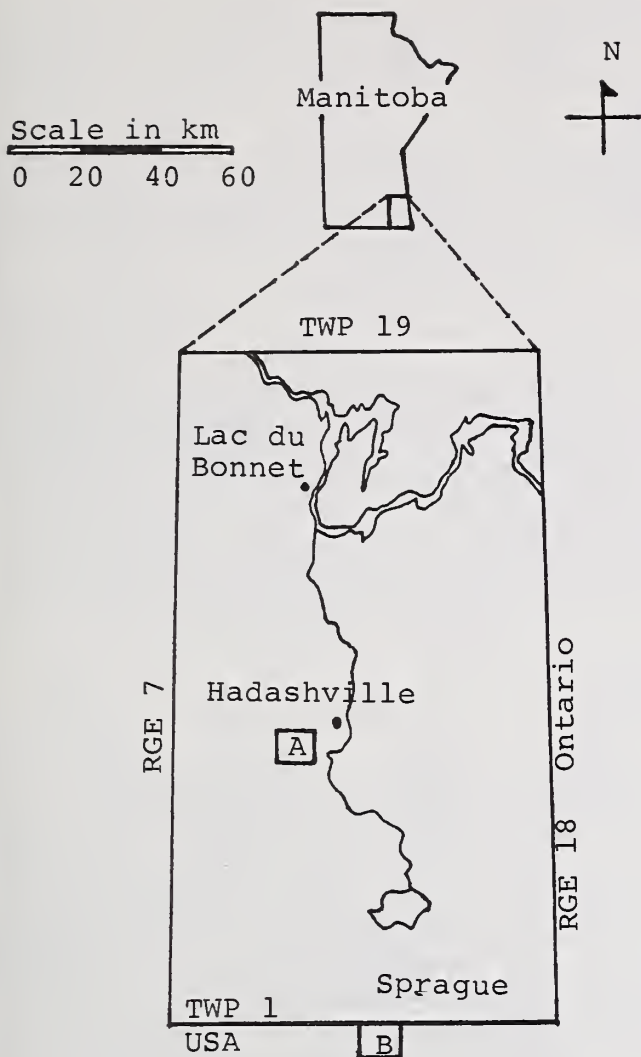

Figure 1.--The study area including two locations, A and B.

lay adjacent to the owl's skin and was completely covered by its plumage. Only the antenna protruded out over the bird's tail.

Owls from sample A and C were snared from perches at or near their nests using a hand-held fiberglass telescoping pole. Some juveniles were captured by hand or with a verbal trap baited with live mice. Owls from sample B were caught along roads using either an artificial or live mouse to lure them close enough for capture in a large, hand-held, fish-landing net (Nero 1980).

From the ground, two or more compass bearings for an individual radio-marked owl enabled its location to be plotted on a map or air photo. Bearings were obtained with a three or four-element, directional hand-held yagi antenna connected to a radio-receiver via a RG-59/U coaxial cable. Radio-signals were detected from as far as 10km with factors such as owl perch height, local topography, signal interference and seasonal changes of deciduous vegetation affecting detection range. When radio-contact from the ground was lost, indicating the owl may have moved out of radio-reception range, an attempt to relocate the owl via aircraft was made. For this purpose a four-element directional yagi antenna was

mounted to each wing of a fixed wing mono-plane. The antenna's elements were positioned vertically and the antennas pointed outward, perpendicular to the flight path. A right-left switch connected both antennas to the receiver via RG-59/U coaxial cables. Search patterns were determined by the last known location of the missing owl, topography and aerial reception range (55-135km at 2500m above ground level). When a signal was detected the owl's location could be determined to within 50m by a number of low level (40m above ground) passes. When weather or fuel constraints prohibited the above, the owl's approximate location and/or bearing was obtained to facilitate relocation, either by aircraft or from the ground, at a later date.

The locations of radio-marked birds were obtained at varying time intervals until their transmitters expired, mortality occurred, or radio-contact was lost. An owl's movements are herein defined as the linear distance between locations as determined by the radio-telemetry techniques mentioned above. These movements represent a minimal value as the owl may have meandered or made detours while enroute between locations.

Recapture attempts were made to remove or replace transmitters about to expire. Signal changes, such as decreased reception range, frequency drift, and orientation of the yagi antenna, indicated possible mortality. Prompt recovery of the transmitter and owl remains was required to determine the cause of death, but was not always possible. The cause of mortality was a subjective decision based on sign such as tracks, feces, feathers, pellets, and teeth marks. Owls with whom radio-contact was lost were searched for on all subsequent search flights until their transmitter's expected expiry date.

On occasion, especially for sample c, the radio-marked owls' behavior was noted. Dense vegetation only rarely prohibited viewing the owls from sufficient distances so as not to disturb them.

2. Small Mammal Census

Locations A & B (fig. 1) were censused for small mammals during the spring (May 21 to June 2, 1986) and fall (October 14-22, 1986). The census at each location consisted of six lines, in three pairs, of 50 stations per line with 10m spacing between the stations of a line. A pair of census lines ran parallel and were 50m apart. One museum special snap-trap, baited with peanut butter, was set at each station for three nights. The lines were checked each morning, trapped mammals removed and traps reset or re-baited as required. In each location, A & B (fig. 1), a pair of census lines sampled a tamarack stand, while the other two pairs sampled open areas containing suitable perches. These areas were used by hunting owls (Servos 1985, Duncan unpubl. data).

RESULTS

Movements

1. Sample A

Recorded post-breeding movements of adults showed sexual differences with respect to the magnitude and chronology. Six of seven adult females left their breeding grounds (i.e., moved at least 10km away and did not return) between October 1 and December 20, 1984, while only one of eight adult males had done so. This difference was significant ($P = 0.0089$, one-tailed Fisher exact probability test, Daniels 1978). All birds had left the area by February 22, 1985. Exact departure dates are not known due to intervals between radio-checks. Only four young owls survived long enough to leave their natal home range and did so prior to December 20, 1984.

Eight adult owls were located on their 1985 summer home ranges. Distances from their 1984 breeding home ranges were 0, 41, 172, and 325km for males and 360, 416, 521, and 684km for females. The average distance for males was significantly less than that for females ($P < 0.05$, one-tailed Mann-Whitney U test, Daniels 1978).

Other owls made substantial movements before radio-contact was lost or mortality occurred. One adult female died on her 1984 breeding home range; three others had moved 15, 164, and 494km before radio-contact was lost. One adult male died on his 1984 breeding home range, two died 77 and 98km away, and two had moved 141 and 398km before radio-contact was lost. Seven young owls died on or within 10km of their 1984 natal home range prior to September 28, 1984. The remaining four died 13, 62, 83, and 102km from their natal home range prior to February 19, 1985. Figure 2 shows a simplified map with movements described above. There were no coordinated movements between males and females of breeding pairs.

2. Sample B

Recorded movements of six late winter-caught owls also suggests some sexual differences in movement patterns. Three of four males, one adult and two immatures (hatch-year 1985), remained within 2km of their capture site.

- An adult male died less than 1km from where it was caught 44 days earlier. It had starved to death, suspended 1m above the ground with its wing wedged in a forked branch.

- An immature male remained within 2km of its capture site for 200 days. Its remains were found adjacent to an active trap line.

- An immature male has remained within 4km of its capture site to date (381 days).

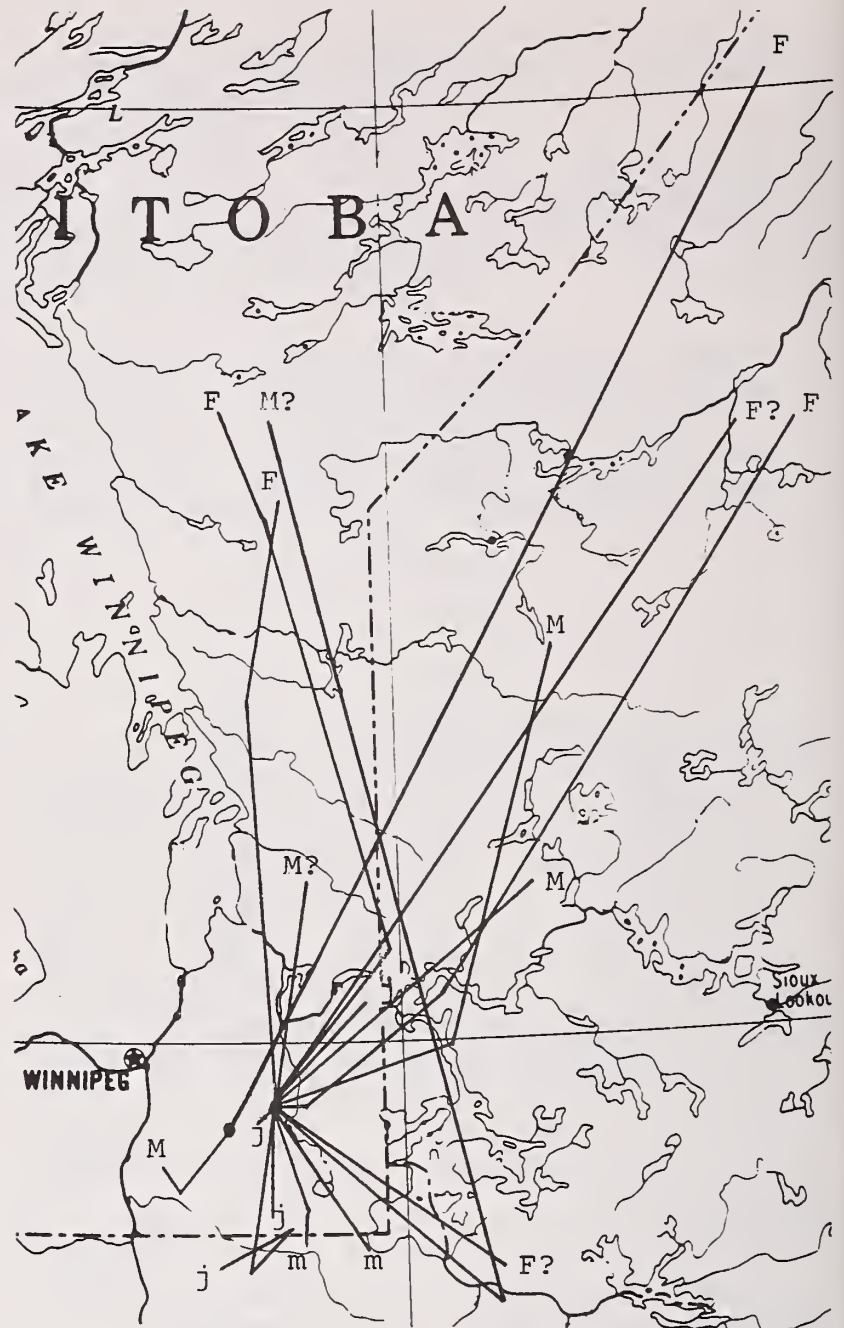

Figure 2.--Recorded post-breeding movements of radio-marked great gray owls: M and F indicate male and female, respectively, on summer 1985 home ranges. A ? denotes last known location of a bird. An m or j marks where mortality occurred for males and juveniles, respectively. Birds are from sample A.

The remaining three owls moved relatively soon after they were radio-marked.

- An immature male moved 112km north 30 days after capture.

- An adult female moved 26km northwest 30 days after capture and was missing 12 days later. Subsequent search flights failed to relocate this owl.

- An adult female moved 21km northeast 12 days post capture. Nine days later it was 112km southeast where its transmitter, but few remains, were recovered.

Table 1.--Suspected cause of mortality of 23 radio-marked great gray owls in southeastern Manitoba and northern Minnesota.

Sample ¹	great horned owl	malnutrition	lynx	fisher	trapped	hunting	accident	unknown
A	9	2	2	2	0		0	0
B	0	0	0	0	1		1	1
C	4	0	0	1	0		0	0

1. See methods for description of samples.

3. Sample C

One of two surviving young, a female, moved 118 north on November 28, 1986. Its sibling, and a pair of adults, remain to date within 5km of their 1986 natal and breeding home ranges respectively. The 5 owls, whose remains and transmitters were recovered, all died within five to 10km of their breeding or natal home ranges from August to November 1986.

Mortality

Table 1 shows the suspected cause of mortality for those owls whose remains and transmitters were recovered. This does not include six owls with whom radio-contact was lost. Since these instances may involve mortality in which the transmitters ceased functioning (i.e., shot or bitten through), values in table 1 are minimal. The 13 great gray owls killed by great horned owls (*Bubo virginianus*) consisted of two adult females, three adult males, and eight young. Malnutrition was the only suspected cause of death in two cases, both involving young birds, however it most likely was a factor in other cases (see discussion). Lynx (*Lynx canadensis*) apparently took two young owls. Fisher (*Martes pennanti*) took one adult female and two young owls. The fate of the remaining three owls (sample B, table 1) was described above.

Small Mammal Census

Table 2 shows an expected increase in the abundance of small mammals in both locations from spring to fall. Location B had the highest abundance for both the spring and fall. The high percentage of red-backed voles (*Clethrionomys gapperi*) in the fall sample (table 2) was also noted for two other independently sampled areas within the northern and eastern portions of the study area denoted in figure 1 (W. O. Pruitt Jr.⁴ and S. Mihok⁵, pers. comm.).

⁴Pruitt, W. O., Jr. 1986. Personal conversation. University of Manitoba, Winnipeg, Manitoba.
⁵Mihok, Steve. 1986. Personal conversation. Pinawa, Manitoba.
⁶Loch, Steve L. 1985. Personal conversation. Foley, Minnesota.

DISCUSSION

In 1984, 19 active great gray owl nests were found in southeastern Manitoba and adjacent Minnesota (Nero, unpubl. data). More than 100 man-made nest structures, covering a linear distance of more than 200km, and including locations A & B (fig. 1), were checked from April to June 1985. None were occupied. Coupled with similar negative results from Minnesota (S. Loch⁶, pers. comm.) it appeared that the vole crash within the study area in the winter 1984-85 (S. Mihok⁵, pers. comm.) carried over into the spring and summer. This suggested that the emigration of great gray owls from southeastern Manitoba (fig. 2) was general and/or birds remaining (i.e., the two adult males, sample A) lacked the stimulus to breed. Movements of owls on summer ranges in the north (fig. 2) suggested that breeding had not occurred there either (Loch 1985)³. However, three of eight great gray owls caught from January to March 1986, plus a road-killed owl, were from the 1985 hatch-year. This suggested that considerable reproduction had taken place within the study area or that new birds had moved in. In 1986, location B (fig. 1) contained the only active great gray owl nests found, which coincided with its moderate spring small mammal population (table 2).

Coinciding with the 1984 generalized microtine crash, adult female great gray owls left their 1984 breeding grounds earlier, and travelled farther, than adult males. Given that the male great gray owl establishes the breeding territory (Nero 1980, Mikkola 1983) the observed adult sex-biased mobility

Table 2.--Abundance indices of small mammals for two locations, spring and fall.

Location ¹	Spring		Fall	
	A	B	A	B
Index ²	1 ³	10	24	43
% <i>Microtus</i> sp.	0	70	12	21
% <i>Clethrionomys</i> sp.	0	19	65	43
% Soricidae	86	6	23	28
% Others	14	5	0	2
Sample size (N)	7	84	217	383

1. See figure 1.
 2. Index, $I = (100 * N) / D$, N = total # caught and D = # traps * # nights.
 3. D = 885, all others D = 900.

pattern would be best explained by the arrival-time hypothesis. This is further supported by the return of one male to occupy an expanded version of its 1984 breeding home range after wintering 40km north. Another male settled into a 1985 summer home range 41km west of its 1984 breeding home range. The greater distances travelled by females, and their earlier departure, apparently contradicts predictions of the body size and dominance hypotheses.

Four young owls from sample A survived long enough to leave their 1984 natal home ranges and did so prior to adult males but concurrently with adult females. Perhaps these young owls are influenced more by social dominance and they are the first to move when conditions get harder. Subsequent mortality of these owls before they could establish 1985 summer home ranges prevents comparisons with the eight adults that did. The high mortality observed (table 1 and results) may have resulted from the young being relegated to poorer habitats. Predators, especially the great horned owl, and malnutrition were the only suspected cause of mortality of owls from sample A. These two factors are probably interrelated and tied in with the small mammal crash. Hungry or starving owls, concentrating on catching prey would be less wary of potential threats. Perhaps the microtine population was insufficient to provide a long enough "training period" to enable the young owls to fully benefit from their inherited extreme ear asymmetry (Norberg 1987)¹. This adaptation, which enables owls to audibly detect and locate prey in dense ground vegetation or under snow, may prove to be a formidable handicap in such situations. Furthermore, a bird moving through unknown habitat would be at a disadvantage when it encountered resident predators. Loch (1985) postulated that following a 10-year cyclic peak in populations of ruffed grouse (*Bonasa umbellus*) and snowshoe hare (*Lepus americanus*), the resulting large population of seasoned predators, i.e., great horned owl and lynx, would broaden their search image to alternate prey species, including the great gray owl. Despite a high fall 1986 microtine population (table 2), predator-related mortality, particularly great horned owl, was high (table 1). Mikkola (1983) notes one instance of the eagle owl (*Bubo bubo*) killing the nominate European subspecies of the great gray owl (*S.n. lapponica*). In North America the great horned owl appears to be a more significant predator of the great gray owl than is the eagle owl in Eurasia.

Movements of great gray owls radio-marked in February and March 1986 (sample B) suggested sexual differences in mobility as well. Males tended to be relatively sedentary compared to females. The adult females' greater mobility at this time may represent a search for males with territories conducive to breeding. The three adult owls, a male and two females, were observed spending much time on high and exposed perches, with frequent flights over tree tops. These may be activities related to spring courtship.

The virtual lack of movements by the radio-marked owls (from sample C) from their 1986 natal and breeding home ranges is most likely due to the increased abundance of their principle prey, voles (table 2). The five owls that died were within 10km of their natal or breeding home ranges. The one exception, a young female, moved 112km north; her sibling remained on their natal home range. This is an enigma, given the amount of suitable habitat and ample prey en route to where she relocated.

Movements of owls from sample B & C were of lesser magnitude than those of sample A (fig. 2), which relocated the majority of owls outside the study area denoted in figure 1. Kerlinger & Lein (1986) found that social dominance alone may explain the winter distribution of snowy owls (*Nyctea scandiaca*). Byrkjedal & Langhelle (1986) related age and sex differences in hawk-owl mobility to two "single factor" hypotheses. Males are more influenced by competition for nest-sites, while females and juveniles, which leave the breeding grounds, may be more influenced by social dominance. Great gray owls seem to parallel the hawk-owl and boreal owl in this respect, at least during times of low prey availability.

Byrkjedal & Langhelle (1986) note that nest-site availability is probably less critical for the hawk-owl, as it is for the boreal owl. The great gray owl is probably the least affected by nest-site availability. However, adult males of all species would benefit by remaining at least within the breeding range to sample food and potential nest-sites (Byrkjedal & Langhelle 1986). Furthermore, given an adequate food supply, it would possibly benefit successful pairs to remain together into the next breeding season, on or near their former breeding territory. A pair of great gray owls that fledged two young in 1986 remained together throughout the winter on their breeding home range. In mid-March 1987 the female was observed following the male, soliciting food from him with barely audible vocalizations similar to the begging calls of the young.

Numerous half to 2 day visits by adult breeding females to neighbouring family groups up to 4km away were documented in the post-fledging period during the 1986 breeding season. During this period the male feeds the young directly (Nero 1980, Mikkola 1983). Similar, but briefer visitations by female flammulated owls (*Otus flammeolus*) was reported by Reynolds & Linkhart (1987). If a female's previous year's mate has not survived to the following year, then an awareness of adjacent males and/or breeding territories would expedite successful reproduction the following year. Reynolds & Linkhart's (1987) study of nest-site and mate fidelity in flammulated owls lends support to this idea. Mikkola (1983) gives several examples of pairs that have bred (or at least have stayed) together for 2 or even more consecutive years at the same nest-site, while voles were scarce in some instances. Recaptures of two banded adult females (Nero, unpubl. data), each nesting three times

within the same immediate breeding area, over a 10 and 7 year period respectively, documents nest-site fidelity in this species.

Evidence of fall territoriality and nest inspections (Duncan, unpubl. data), together with the above data, suggests year-round residency to be an adaptive behavioral strategy for great gray owls. Winter (1987⁷ and pers. comm.) found great gray owls in Yosemite National Park, California, using pocket gophers (Thomomys botta/monticola) as maintenance prey items, enabling year-round residency, but not breeding, during cyclic lows in microtine populations. In Oregon, Bull & Henjum (1987) found the maximum distance that 16 adult radio-marked great gray owls ranged from their nests, over 1 to 3 years, averaged 13km (+11). Movements of these birds, living in mountainous terrain, was thought to be a function of topography, with owls travelling short distances to change elevation, snow depth, and prey vulnerability. For great gray owls in southeastern Manitoba to accomplish the same, greater distances must be travelled, at least during years of low microtine populations (i.e., 1984-85). Movements of radio-marked adults north (fig. 2) actually placed birds at lower elevations, and possibly in locations of lesser snow depths and/or greater prey vulnerability.

The great gray owl's larger size and weight (Mikkola 1983) should make it even more likely to be a year-round resident than the smaller and lighter boreal and northern hawk-owls. These three species occupy the same range- the boreal forest -and are potentially strong competitors. Snow accumulations partially protect voles from these predators but the least affected is the great gray owl (Korpimäki 1986b). Their large size and peculiar habit of snow-plunging enables them to regularly catch voles through even hard snow layers up to 50cm deep (Collins 1980, Nero 1980, Korpimäki 1986b, Duncan, unpubl. data). The great gray owl's larger body mass should be more efficient at thermoregulation and better able to withstand temporary food shortages than its smaller competitors, even though a larger body requires more food (Korpimäki 1986b). The lower critical temperature, i.e., the point below which body temperature cannot be maintained without increased heat production, declines as body size increases. Therefore, the metabolic rate of a larger animal starts increasing at a lower temperature than is the case for a smaller animal. Also, a larger bird takes longer to starve to death (Peters 1983 in Korpimäki 1986b).

The various adaptations, both anatomical and behavioral, discussed above maximize the ability of great gray owls to achieve residency for as long as possible. These are means which minimize the destabilizing influence of dependence on a wildly fluctuating prey base.

⁷Winter, J. 1987. Personal conversation. 5331 El Mercato Parkway, Santa Rosa, California.

ACKNOWLEDGEMENTS

Thanks are due those contributing to this study, especially Dr. R. W. Nero, Manitoba Department of Natural Resources. H. Copland, S. Loch, R. Lasnier, Z. Shahzada, B. Carson, R. Rouire, P. Lane, S. Mihok, and B. Schwartz all provided essential assistance. Funds or services were provided by World Wildlife Fund, Canada, The Murphy Foundation Inc., Abitibi-Price Inc., Ontario Ministry of Natural Resources, the Manitoba Department of Natural Resources, and the Natural Resources Institute, University of Manitoba.

LITERATURE CITED

- Byrkjedal, L. and G. Langhelle. 1986. Sex and age biased mobility in hawk-owls Surnia ulula. Ornis Scand. 17:306-308.
- Collins, K. M. 1980. Aspects of the biology of the great gray owl. M. Sc. thesis, University of Manitoba, Winnipeg, Manitoba. 219pp.
- Daniel, W. W. 1978. Applied nonparametric statistics. 503pp. Houghton Mifflin Co., Boston, Mass..
- Kerlinger, P., and M. R. Lein. 1986. Differences in winter range among age-sex classes of snowy owls Nyctea scandiaca in North America. Ornis Scand. 17:1-7.
- Ketterson, E. D., and V. Nolan Jr. 1983. The evolution of differential bird migration. In Johnston, R. F. (ed.). Current Ornithology, Vol. 1. Plenum Press, New York. pp 357-402.
- Korpimäki, E. 1986a. Reversal size dimorphism in birds of prey, especially in Tengmalm's owl Aegolius funereus: a test of the "starvation hypothesis". Ornis Scand. 17:326-332.
- Korpimäki, E. 1986b. Niche relationships and life-history tactics of three sympatric Strix species in Finland. Ornis Scand. 17:126-132.
- Lundberg, A. 1979. Residency, migration and a compromise: adaptations to nest-site scarcity and food specialization in three Fennoscandian owl species. Oecologia (Berl.) 41:273-281.
- Mihok, S., Turner, B. N., and S. L. Iverson. 1985. The characterization of vole population dynamics. Ecological monographs 55(4):399-420.
- Mikkola, H. 1983. Owls of Europe. Buteo Books, Vermillion, South Dakota. 397pp.
- Nero, R. W. 1980. The great gray owl: phantom of the northern forest. Smithsonian Institution Press. Washington, D. C. 167pp.
- Roselar, C. S. 1985. Great grey owl. In: Cramp, S. (ed.). Handbook of the birds of Europe, the Middle East and North Africa: the birds of the western palearctic. Vol. 4. Terns to woodpeckers. Oxford University Press, Oxford.
- Servos, M. 1986. Summer habitat use of the great gray owl (Strix nebulosa) in southeastern Manitoba. M. Sc. thesis, University of Manitoba, Winnipeg, Manitoba. 81pp.
- Sonerud, G. A. 1986. Effect of snow cover on seasonal changes in diet, habitat and regional distribution of raptors that prey on small mammals in boreal zones of Fennoscandia. Holarctic Ecology. 9:33-47.

Summer Habitat Use by Great Gray Owls in Southeastern Manitoba¹

Marla C. Servos²

Abstract.--Sixteen radio-marked great gray owls, *Strix nebulosa*, were monitored from 27 June to 28 August 1984 to determine summer habitat use in southeastern Manitoba. Owls showed a strong preference for tamarack bogs, but other wet, open areas with adequate perches, such as treed muskeg habitats were also selected. Factors influencing habitat selection include availability of prey species (meadow voles and bog lemmings), suitable perches, cover, and shrub density.

INTRODUCTION

Great gray owls are generally rare across most of their range and their nomadic nature makes them difficult to study. Knowledge of the great gray owl's preferred habitats is limited although there is evidence of a preference for black spruce-tamarack bogs in Manitoba, for mature poplar stands near muskeg in Alberta and for mature old forests in California (Nero 1980). A better understanding of the preferred habitats of great gray owls is an important first step in the effective management of this species.

In the spring of 1984 six pairs of great gray owls nested in a small area of southeastern Manitoba, approximately 70 km east of Winnipeg. This large number of breeding owls in a relatively small, easily accessible area presented a unique study opportunity. As part of a continuing great gray owl research project by the Manitoba Wildlife Branch, 18 owls were radio-marked in the spring of 1984. This study focused on the summer habitat use of these radio-marked owls.

¹Paper presented at the symposium, Biology and Conservation of Northern Forest Owls, Feb. 3-7, 1987, Winnipeg, Manitoba. USDA Forest Service General Technical Report RM-142.

²Natural Resources Institute, University of Manitoba, Winnipeg, Man. Present address: 27-30 Baylor Ave., Winnipeg, Man. R3T 3K1

MATERIALS AND METHODS

Study Area

The study area was located in southeastern Manitoba, approximately 70 km east of Winnipeg in the Sandilands Provincial Forest. The 1942 ha study area lies within the Manitoba Lowlands section of the Boreal Forest Region which is noted for its flat, poorly drained land with the predominant vegetation consisting of patches of black spruce and tamarack interspersed with swamps and meadows (Rowe 1972). Jack pine and trembling aspen are found on the drier areas.

A large portion of the study area was covered by tamarack bog (TL100) and five occupied nests were located on the edge of, or within this habitat type (fig. 1; habitat codes are described in table 1). The southern portion of the study area was the driest and its habitat types were composed mostly of jack pine, black spruce and trembling aspen. The wettest habitat types, the marsh muskeg (MARMUS), treed muskeg (TREMUS), class-0 (an old burn area), and tamarack bog (TL100), ran from the northwest corner diagonally across the middle of the study area and occupied the largest area. The northern portion was a relatively dry area composed mostly of young jack pine and trembling aspen with a thick shrub undergrowth.

Radio-telemetry

Eighteen great gray owls nesting in the study area were radio-marked during spring 1984 as part of a larger project of Dr. R.W. Nero, Manitoba Department of Natural Resources. Two of these birds were

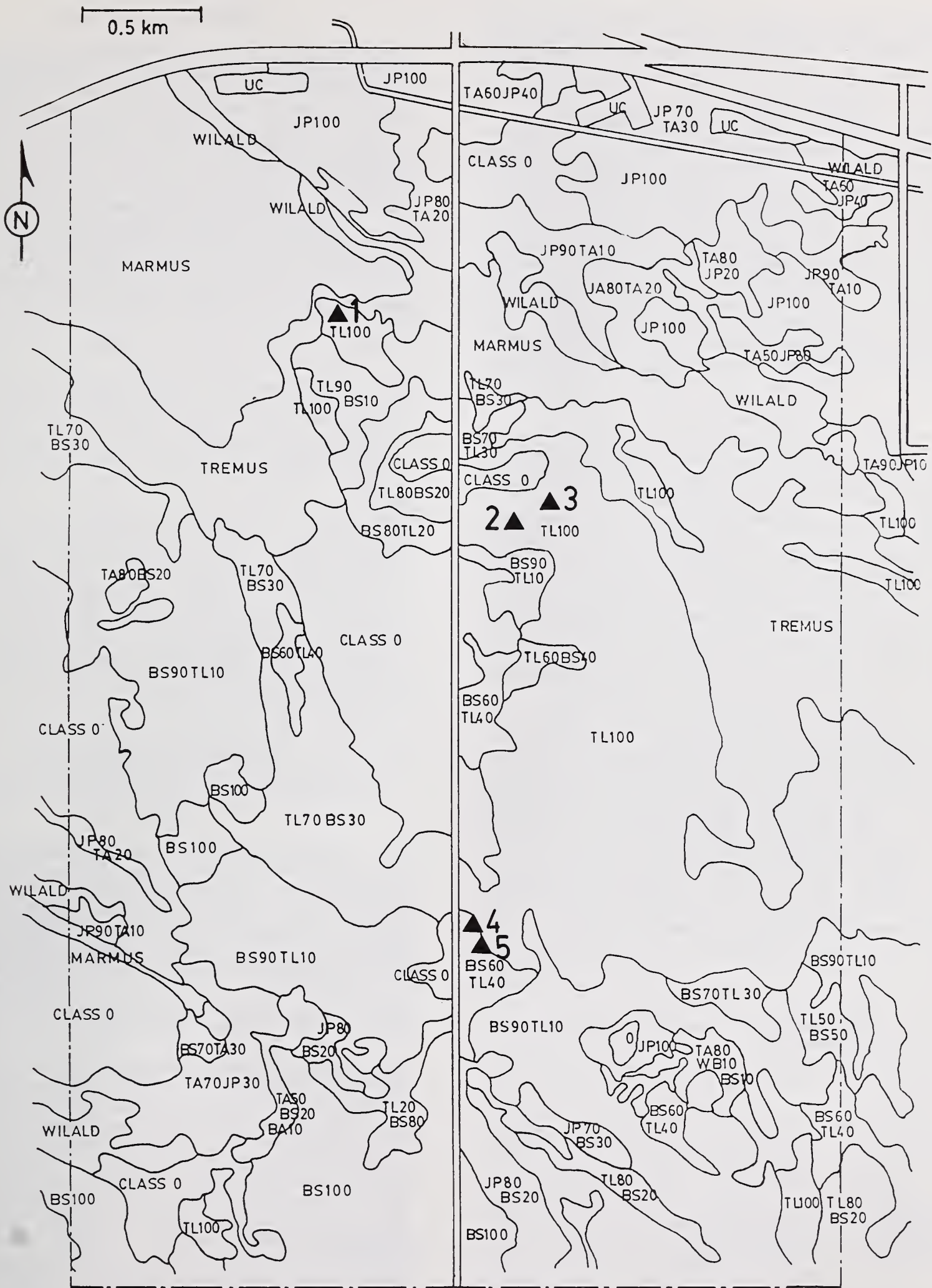

Figure 1.--Habitat types and nest locations in the the study area. ▲- occupied nest

eliminated from the study due to mortality. Sixteen radio-marked birds, five males, five females and six juveniles, were used to determine summer habitat selection. Radio-telemetry readings to determine the locations of the owls were taken on 31 different days from 27 June 1984 to 28 August 1984 and at all times of the day. The location of each owl, as determined by triangulation, was plotted on 1:15,840 scale air photos and each location was assigned to a habitat type defined using 1980 forest inventory maps. The receiving equipment consisted of an AVM Model LA-12 radio-tracking receiver and a four element, hand-held, 164 MHz Yagi antenna. The transmitters ranged in frequency from 164.014 to 164.842 MHz. The accuracy of this radio-telemetry equipment was on average 11 degrees.

Analysis was done on 608 owl locations. Radio-telemetry locations for individual birds were plotted and copied onto transparencies to be overlaid on the habitat map. The method for analyzing utilization-availability data described by Neu et al. (1974) and Byers et al. (1984) was employed. A chi-square goodness-of-fit test was used to determine whether there was a significant difference between the observed frequency of habitat use and the expected use of those habitats based on their availability (Byers et al. 1984). Bonferroni confidence intervals were then used to determine whether a specific habitat type was preferred or avoided.

The chi-square goodness-of-fit test was applied on all the data combined; on the data grouped by male, female, young; on the data grouped by month (June, July, August); and on the data grouped by time of day (morning: 0500-1100; afternoon: 1100-1700; evening: 1700-2300; night: 2300-0500). If the null hypothesis was rejected for any of the above cases, Bonferroni confidence intervals were calculated and compared for each habitat type.

Table 1.--Shortened codes for habitat designations.¹

Code	Description
BS	black spruce
TA	trembling aspen
TL	tamarack
JP	jack pine
Class-0	old burn
MARMUS	marsh-muskeg
WILALD	willow alder
TREMUS	treed muskeg

¹e.g. TL90BS10 describes a 90% tamarack-10% black spruce habitat.

Vegetation Analysis

As a check on the forest inventory maps, vegetation analysis using the point-centered quarter method (Cottom and Curtis 1956) was conducted on seven habitat types: five of the most common habitat types used by the owls and on two areas where the owls were never found. At each sampling point canopy cover was estimated ocularly, ground cover estimated using a 1 m x 1 m quadrat and shrub density (# stems/m²) was estimated using a 2 m x 2 m quadrat. Plants greater than 1 m in height were classified as shrubs and those less than 1 m were defined as ground cover.

Prey Abundance and Use

Small mammal trapping was conducted during July and August 1984 to determine relative abundance in the seven habitat types where vegetation analysis was done. Thirty Museum Special traps were set each night for three nights and were baited with peanut butter and rolled oats. The traps were set 10 m apart on randomly selected transects. The transects were moved after each trap night to reduce bias caused by variation within the habitat types. To determine what prey species the great gray owls were using, 110 owl pellets were collected in the study area from nests and roost sites from May to August 1984; dried and the skeletal remains were extracted for identification.

RESULTS AND DISCUSSION

Owl Pellet Analysis and Small Mammal Trapping

Analysis of the owl pellets collected on the study area revealed that the majority of the great gray owls' diet was composed of meadow voles (Microtus pennsylvanicus, 64%) and northern and southern bog lemmings (Synaptomys borealis and S. cooperi, 28%). Other species taken included mice (Family Cricetidae, 5%), red-backed voles (Clethrionomys gapperi, 2%) and songbirds (1%).

Meadow voles, red-backed voles and shrews were caught in all seven habitat types. Bog lemmings were caught only in the 90% tamarack-10% black spruce (TL90BS10), treed muskeg, 90% black spruce-10% tamarack (BS90TL10) and the 80% jack pine-20% black spruce (JP80BS20) habitat types. Deer mice (Peromyscus maniculatus) and meadow jumping mice (Zapus hudsonius) were caught only on the driest habitats, JP80TA20 and JP90TA10. More meadow voles than any other species were caught in the pure tamarack, class-0 and treed muskeg habitats.

Habitat Selection

All 16 radio-marked owls remained in, or within 0.5 km of the study area for the duration of the study. By 27 June 1984 all young owls were out of the nest and able to move from tree to tree although not yet flying. The male and female owls at nest 1 remained in the nest area and were seldom found on the east side of the forestry road. Both owls appeared to occupy the same range and frequented the TL100, TL90BS10 habitat types and the edges of the marsh-muskeg. The young owls and the male at nest 2 were always found on the east side of the road near the nest site in the TL100 habitats and in the areas with a high percentage of tamarack trees. The female from this family group apparently had dissociated from the male and young and was found mostly on the west side of the road. The family group from nest 3 followed a similar pattern. The ranges of the male and young from nest 2 and 3 overlapped as did the ranges of the female owls.

The owls from nest 4 and 5 moved north of their nest sites. The young and male of nest 4 were found in the same area, on the east side of the road, generally in the tamarack bog (TL100) although the male ventured further east than the young. The female from nest 4 was found in the same area as the male and young but also used the class-0 habitat on the west side of the road. The male and female of nest 5 were generally found on the west side of the road in the class-0 and TL70BS30 habitats. Fixes on the young of this nest, done only twice due to transmitter problems, placed the bird on the west side on the edge of the class-0 habitat.

The home ranges of the male owls from nests 2, 3 and 4 appeared to overlap. The range of the male from nest 5 overlapped with the nest 4 male and approached the range of the other males. The nest 1 male occupied an area in the northwest part of the study area and its range did not appear to overlap with the others.

The chi-square goodness-of-fit test on the radio-telemetry data lead to the rejection of the null hypothesis since the chi-square test value was larger than the chi-square table value in all cases. Thus the owls were not entering the different habitats by chance alone but were selecting or avoiding certain habitat types. Bonferroni confidence intervals applied for each habitat type showed a strong preference for the pure tamarack bog (TL100) by males, females and young, during August and during all time periods (table 2). Overall, the class-0 (old burn), the treed-muskeg (TREMUS) and the 90% tamarack-10% black spruce (TL90BS10) habitat types were also selected. Although these results can not explain why the owls

are selecting these habitats, possible explanations can be suggested as to why great gray owls select certain habitat types in preference to others.

The great gray owls in this study area showed a strong preference for pure tamarack bog areas. The tamarack bogs were generally free of a dense shrub layer (shrub density 0.45 stems/m²) and the ground cover was mostly low-growing mosses and grasses. These vegetation characteristics would make it easy for the owls to locate and capture their prey. The horizontal growth of the tamarack branches would provide suitable perches. Although the average canopy cover was only 35%, this habitat would appear to provide sufficient concealment and cover for the young owls. This habitat also supported their preferred prey species, the meadow vole.

The 90% tamarack-10% black spruce (TL90BS10) habitat type was selected by females, used by males, but not used at all by young. This habitat was also selected by all owls overall in August. Except for the lack of shrub growth, this habitat was similar in vegetation characteristics to the pure tamarack bog and therefore was probably a preferred habitat for the same reasons. Both bog lemmings and meadow voles, which made up the largest portion of the diet of these owls, were caught in this habitat type.

The class-0 habitat type was an old burn area and was preferred by female owls but was not selected or avoided by males and young. Class-0 habitat was also selected by the owls in July. This preference by females, especially in late summer, may indicate a dissociation of the females from the family group. Since the male owls continue to feed the young long after they are out of the nest (Nero 1980), the females may move to other hunting areas. The class-0 habitat would appear to be favourable for hunting activities. More meadow voles than any other species were trapped in this habitat type. Dead trees left standing after the burn were scattered throughout the area and provided good perches for hunting. Although the shrub growth was more dense here than in the tamarack bog, the shrubs were generally concentrated in clumps, leaving areas of unimpeded access to prey on the ground. Black spruce are regrowing in this habitat but do not yet form a canopy, allowing for unhindered flight through the lower vegetation. But this lack of canopy cover would provide little or no shade or concealment and may explain why the males with the young did not select this habitat type.

The treed muskeg (TREMUS) habitat was preferred by the great gray owls although there was no significant selection in the

Table 2.--Summary of the Bonferroni confidence intervals. $P < 0.05$ $df = n/K - 2$
 S-selected A-avoided 0-zero frequency of use
 N-no significant difference @-see table 3

Habitat	DATA GROUPINGS										
	Overall	By sex (age)			By month			By time of day			
		M	F	Y	June	July	Aug.	0500-1100	1100-1700	1700-2300	2300-0500
TL100	S	S	S	S	N	N	S	S	S	S	S
CLASS0	S	N	S	N	N	S	N	N	N	N	N
TL90BS10	S	N	S	0	N	N	S	N	N	N	N
TREMUS	S	N	N	N	N	N	N	N	N	N	N
BS90TL10	A	A	A	A	0	A	N	A	N	N	N
MARMUS	A	N	N	A	N	A	N	N	N	N	N
WILALD	A	A	0	0	0	0	0	0	0	0	0
OTHER @	0	0	0	0	0	0	0	0	0	0	0
BS60TL40	N	N	N	N	0	N	N	N	N	N	N
BS70TL30	N	N	0	0	0	N	0	0	N	0	0
BS80TL20	N	N	N	0	N	N	N	N	N	N	N
TL50BS50	N	N	N	0	0	0	N	0	0	N	N
TL60BS40	N	0	N	N	0	N	N	N	N	N	0
TL70BS30	N	N	N	N	N	N	N	N	N	N	N
TL80BS20	N	0	N	0	0	0	N	N	0	0	0

individual data groupings (table 2). The treed muskeg was similar in vegetation characteristics, although much wetter, to the class-0 habitat. Clumps of tamarack trees scattered throughout this area probably supplied hunting perches. Shrub growth in the treed muskeg was denser (7.35 stems/m²) than in the class-0 habitat but the shrubs were generally associated with clumps of tamarack trees, leaving open areas ideal for hunting. Also, hunting was probably favoured in this habitat due to the presence of both meadow voles and bog lemmings. As was the case in the class-0 habitat, the treed muskeg would provide little cover or concealment for young owls and it is likely that the young tended to remain in the adjacent tamarack bog. The adults probably hunted in the treed muskeg habitat but it was not strongly selected relative to the tamarack bog.

The results of the Bonferroni confidence intervals (table 2) showed that three habitat types were avoided: 90% black spruce-10% tamarack (BS90TL10), marsh-muskeg (MARMUS), and willow-alder (WILALD). Great gray owls were occasionally found in these areas but less than expected according to the availability of that habitat. The remainder of the study area, as described in table 3, was never used by these owls. It was assumed, therefore, that the great gray owls were avoiding these remaining areas since there were no apparent barriers or impediments to their movement into these habitats.

The great gray owls in this study area avoided the 90% black spruce-10% tamarack (BS90TL10) stands and appeared to be neutral towards or avoided any stands that

were greater than 60% black spruce. Of that area never used by the great gray owls, 21% was composed of such stands with more than 60% black spruce (table 3). The avoidance of these stands may be due to the apparently low number of meadow voles available. The majority of species caught in the BS90TL10 habitat were shrews (60%) and no shrews were found in the pellets of the great gray owls in this study. If prey species are not scarce in the study area, then the owls may hunt in those habitats where meadow voles are more abundant.

The marsh-muskeg (MARMUS) habitat was avoided for all data combined and avoided by the young, and in July. Owl use of this habitat in all other cases was not significantly different from the expected use (i.e. not selected or avoided). The marsh-muskeg habitat was a wet habitat with areas of open water. There were no trees growing in this area but clumps of shrubs greater than 2 m in height were scattered throughout. This habitat provided no perches for hunting or resting owls and no cover or concealment. It would have been difficult for pre-fledgling owls to move about in the marsh-muskeg with no trees to climb up or to fly between.

The willow-alder (WILALD) habitat was also avoided overall but in many cases (i.e. for females, young, in June, July and during all time periods except 1100 to 1700) it was not used at all during this study (table 2). Results of the analysis on the use of the willow-alder that did occur showed that the area was avoided by male owls, and by all owls in August. There was no significant difference between

observed use and expected use of this habitat during the 1100 to 1700 (afternoon) time period. This habitat had no trees and the dense shrub growth would have made it difficult for owls to fly through to reach prey on the ground. Again, the lack of trees means no perches or adequate cover for owls.

All other habitat types used by the owls (listed in table 2) were neither selected nor avoided. The remainder of the study area, comprising approximately 620 ha or 32% of the total area, was never used by the owls and was considered to be avoided. Almost 50% of these habitat types that were never used by the great gray owls were composed of stands of black spruce or jack pine (table 3). Avoidance of these black spruce stands was discussed previously. Approximately 33% of this never-used area was composed of stands that were greater than 70% jack pine. Why the great gray owls avoided these habitat types is not certain particularly since meadow voles were available. There may have been a lack of suitable perches in this habitat due to the lack of dead trees and also due to the downward sloping nature of jack pine branches. Young owls would have found it difficult to climb into the jack pine because there were few branches low enough on the trunk and no leaning trees to "walk" up.

Time of day did not appear to affect the owls' selection of habitat. The tamarack bog (TL100) was selected during all times of the day. The black spruce 90%-tamarack 10% (BS90TL10) was avoided in the morning (0500-1100) but was neither avoided nor selected during the rest of the day (table 2). Generally, examining habitat use by time of day did not show any significant patterns of use.

Table 3.--Description of habitats not used by great gray owls.

Major species in habitat (%)	% of area not used
Black spruce 100%	16
Black spruce 60-90%	10
Jack pine 100%	18
Jack pine 70-90%	16
Tr. aspen 50-70%	14
Tamarack 100%	2
Tamarack 60-90%	6
Class-0	7
Unclassified	2
Willow-alder	6
Marsh-muskeg	3
Treed-muskeg	0
Total study area = 1,942 ha	
Never-used area = 620 ha	

Management Implications

Those habitats not used or seldom used by the great gray owls, particularly the black spruce and jack pine stands, should not be dismissed as unimportant to the owls. These avoided habitats, especially the drier stands, could be an important source of prey species. During the relatively dry seasons these prey species may move from these drier areas into the bog and muskeg areas, providing food for the great gray owls. The great gray owls are likely selecting habitat types that can meet most of their biological needs. They would favour those habitats not far from their nest (probably < 1 km), that would provide acceptable prey species, unimpeded hunting (i.e. adequate perches, no dense shrub layer), and cover for shade and concealment from predators for both young and adults.

The results suggest that black spruce and jack pine stands are not critical great gray habitat except as a source of prey species as discussed above. Therefore harvesting these stands which are important to the forestry industry would not seriously affect great gray owl habitat in southeastern Manitoba. If these habitat types are located near (i.e. within 1 km) tamarack bogs or treed muskeg areas, cutting practices could be adjusted to benefit these owls. Cutting these black spruce and jack pine stands would open the canopy allowing for more grass growth and better habitat for small mammal populations. Rather than clear-cutting these areas, trees or patches of trees should be left standing throughout to provide perches for hunting owls.

Stands of black spruce and jack pine without accompanying tamarack bogs or muskeg areas are probably not attractive habitats for great gray owls and could be harvested without serious affect on owl habitat. However, future research would give more insight into the full value of these habitat types. These stands may be used by great gray owls when conditions change. For example, in wetter years when the water level in the tamarack bogs and treed muskeg remains high, prey species, and thus the owls, may move into the black spruce and jack pine habitats. These habitats may also be used more if nests were available. In the study area man-made nests are purposely installed only in tamarack bog habitats. An interesting study could address whether great gray owls would use nests located in adjacent black spruce or jack pine stands.

Great gray owls in southeastern Manitoba appear to select tamarack or tamarack-spruce bogs and treed muskeg areas. Nero (1980) believed that tamarack-black spruce bogs east of Winnipeg are similar in many aspects to owl breeding

range in the northern transition forest. This tamarack-black spruce muskeg area is approximately 40 to 50 km wide and runs about 200 km north and south along the edge of the Precambrian Shield (Nero 1980). This area is composed of old burns, cleared forests, marginal cropland, pine and spruce woods, and bogs and streams. The transitional nature of the forests in this region, a result of burning and clearcutting, possibly makes it prime breeding habitat for great gray owls (Nero 1980).

Although this type of habitat appears to be in sufficient supply in southeastern Manitoba, there is the danger of losing tamarack bog areas to forestry, peat extraction and agriculture. Tamarack forests, once considered to be of marginal value and cut only occasionally for fence posts or firewood, are now being clearcut in extreme southeastern Manitoba as the demand for tamarack for pulp increases (Nero 1984). This practice could leave large areas of the tamarack bog region unsuitable for great gray owl habitation. These bog areas are also threatened by new demands for peat, for mulch in Manitoba and energy in Minnesota, and by continued development of marginal land for agriculture (Nero 1984). Loss of forested boglands means elimination of habitat for owls and other wildlife species (e.g. moose, deer, furbearers). It is important to maintain areas of suitable habitat in southeastern Manitoba where these owls could be available for many people to enjoy.

The status of owls is greatly affected by man's activities and attitudes towards wildlife (Mikkola 1983). Man has an affect on the fate of wildlife populations, directly by destruction of wildlife itself, and indirectly by destruction of habitat. Habitat is probably the single most important factor to consider when attempting to protect a species (Mikkola 1983). Unfortunately little is known about the preferred habitat of the great gray owl across its North American range. There is information only on selected areas such as southeastern Manitoba, central Alberta, northern California and Oregon. We need to know more about the population status of this species across its range, as well as its preferred habitats, so that we are better able to protect those habitats that are critical and able to assess the affects of forestry and other habitat disturbances on the overall population. One of these critical habitats appears to be tamarack

bogs in southeastern Manitoba. A better understanding of the habitat needs of the great gray owl would aid the future management of this species.

ACKNOWLEDGMENTS

I gratefully acknowledge the assistance of S.L. Loch who put the radio-transmitters on the owls, J. Dubois, Manitoba Museum of Man and Nature who identified prey remains in owl pellets, J. Lotimer, Ontario Ministry of Natural Resources and F. Anderka, Canadian Wildlife Service who modified the radio-receivers and C.D. Russel who assisted in collection of field data. The advice and criticisms of M.R. Servos, T. Henley, M.W. Shoesmith, R.R. Riewe, R.W. Nero and W.R. Henson were particularly valuable. Funding was provided by the Manitoba Department of Natural Resources through the Great Gray Owl Research Fund and the Natural Resources Institute, University of Manitoba.

LITERATURE CITED

- Byers, C.R., R.K. Steinhorst and P.R. Krausman. 1984. Clarification of a technique for analysis of utilization-availability data. *J. Wildl. Manage.* 48:1050-1052.
- Cottam, G. and J.T. Curtis. 1956. The use of distance measures in phytosociological sampling. *Ecology* 37:451-460.
- Mikkola, H. 1983. *Owls of Europe*. Buteo Books, Vermillion, S.D. 397 pp.
- Nero, R.W. 1980. *The Great Gray Owl: Phantom of the northern forest*. Smithsonian Institution Press, Washington, D.C. 167 pp.
- Nero, R.W. 1984. The Great Gray Owl in Manitoba, 1968-83. *Blue Jay* 42:130-151.
- Neu, C.W., C.R. Byers, and J.M. Peek. 1974. A technique for analysis of utilization-availability data. *J. Wildl. Manage.* 38:541-545.
- Rowe, J.S. 1972. *Forest regions of Canada*. Canadian Forestry Service, Department of Fisheries and the Environment. No. 1300. Ottawa 172 pp.

Status of the Great Gray Owl in Finland¹

Olavi Hildén² and Taplo Solonen

Abstract.--The paper summarizes the present information on the occurrence of the Great Grey Owl in Finland, providing a background to a series of colour slides taken by Finnish bird photographers. The number of nests found in Finland has increased considerably since the early 1960s, mainly due to intensified research, but the range and abundance vary greatly from year to year in parallel with the local fluctuations of vole populations. The peak years follow the 3-to-4-year vole cycle. In the latest peak year, 1985, the total Finnish population was estimated roughly at about 1500 breeding pairs. Following aspects are treated in the paper: distribution, abundance and population trends, site tenacity, habitat requirements and the effects of forestry, nest sites, food and hunting technique, movements and invasions.

Up to the middle of the 1960s, the biology of the Great Grey Owl *Strix nebulosa lapponica* in Finland was virtually unknown. But since then, the information has rapidly grown, dozens of nests are found nowadays during peak breeding years, and a number of papers have been published (see the reviews by Hildén & Helo 1981, Mikkola 1981, 1983, Helo 1983, 1984, Solonen 1986). The great interest in this species is shown by the fact that in the vast literature dealing with the ten owl species breeding in Finland, most papers (23%) have been devoted to the Great Grey Owl (Korpimäki 1985).

The aim of this article is to summarize briefly the present knowledge of the status of the Great Grey Owl in Finland, as a background to a series of photographs shown at the symposium. We have focused the presentation on the distribution, abundance and size of the Finnish population, and also given some data on habitats, nest sites and invasions, but largely omitted the breeding biology, food and hunting technique which are described in detail in the recent literature (Hildén & Helo 1981, Mikkola 1981, 1983).

¹Paper presented at the symposium, Biology and Conservation of Northern Forest Owls, Feb. 3-7, 1987, Winnipeg, Manitoba. USDA Forest Service General Technical Report RM-142.

²Olavi Hildén is with the Zoological Museum, University of Helsinki, Helsinki, Finland.

DISTRIBUTION AND ABUNDANCE

In Finland the Great Grey Owl has bred in good vole years in almost all parts of the country, except the northern- and southernmost areas. Because vole populations fluctuate differently in different parts of the country (e.g. Henttonen 1986), also the range and number of Great Grey Owls vary irregularly from year to year (Fig. 1). In most years the breeding is confined to the eastern and relatively northern parts of Finland, but the centre of occurrence varies, and the range seems to have shifted southwards in recent times (Hildén & Helo 1981).

The number of Great Grey Owl nests found in Finland has increased considerably since the middle of the 1960s (Fig. 2), in parallel with the steadily growing interest of bird-watchers in owls. How much the population itself may have increased during this period is hard to say, but Mikkola (1983) and Helo (1984) believe that the species in reality also has become more common. At least a real increase is undisputable compared to the situation from the late 1930s to the early 1960s, from which period very few observations exist (cf. Mikkola & Sulkava 1969, Hildén & Helo 1981). Peak years of breeding have followed at intervals of 3 to 4 years, largely following the annual rhythm of vole cycles.

The most exceptional distribution and abundance of territories was recorded in 1985, when Great Grey Owls bred even on the southern coast of Finland (Solonen 1986). The number of nests and fledged broods found totalled about 70, and at

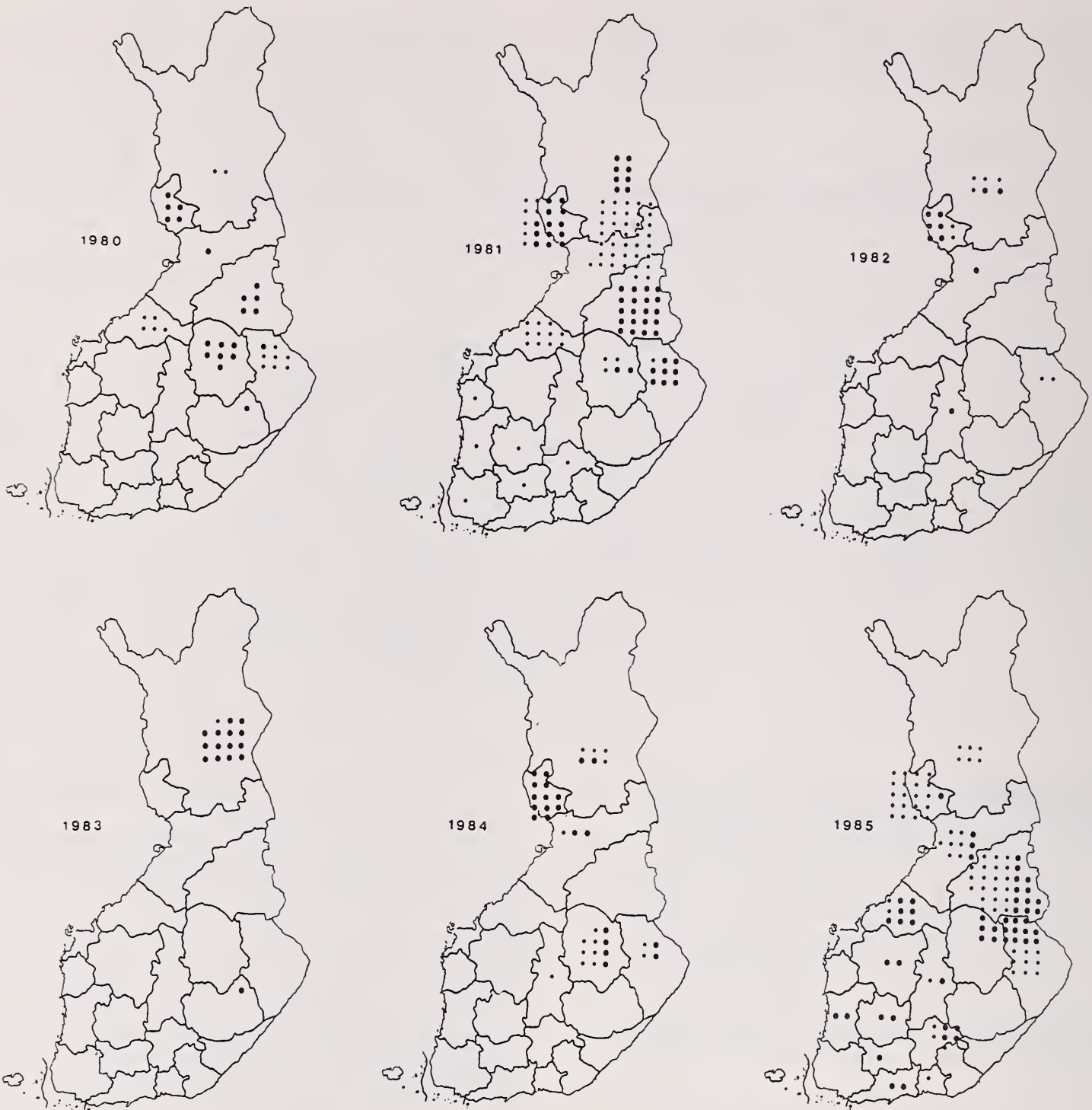
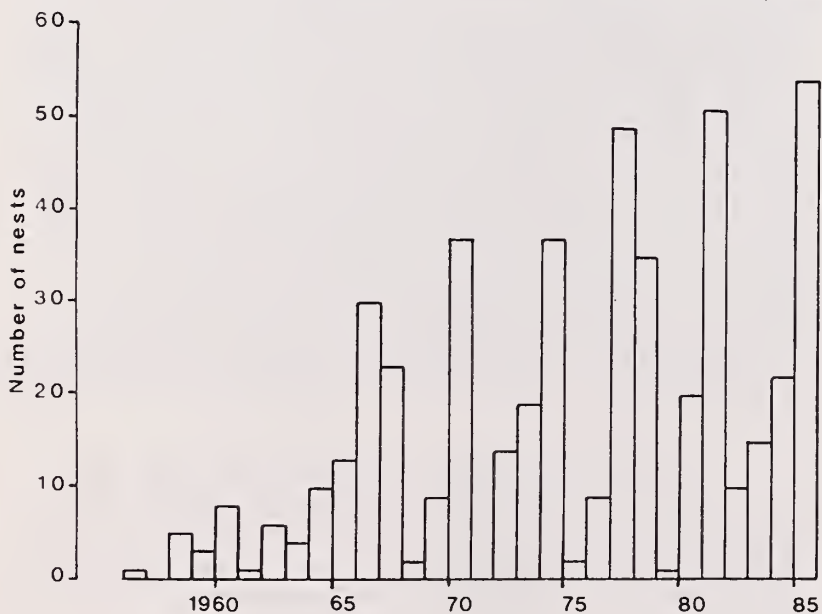

Figure 1.--Territories and nests (large dots) of the Great Grey Owl recorded in Finland in 1980-85 (from Solonen 1986).



least 130 territories were located. The Finnish breeding population was estimated that year at about 1600 pairs (Solonen 1986), based on the approximate number of suitable nest sites (c. 50,000) and the proportion of those occupied by Great Grey Owls in different parts of the country (54 out of c. 3000 checked). This figure is considerably higher than those presented earlier (Saurola 1985), but all the population estimates of this species are inaccurate and should be taken with caution.

Figure 2.--The numbers of Great Grey Owl nests recorded in Finland in 1956-85 (Mikkola 1983, Solonen 1986).



Photo: Antti Leinonen

General densities of the Great Grey Owl are low, but locally there may occur concentrations of several pairs within a few square kilometers. Several occasions of simultaneously occupied nests only 100-300 m apart are known (Hildén & Helo 1981), and in one extreme case the distance was only 49 m (Lehtoranta 1986). At these two nests very close to each other only one male was seen, so polygyny seems possible. Mikkola (1983) has suggested polygyny on two occasions. The breeding concentrations probably are not socially induced but due to an exceptional abundance of voles in certain places and lack of strict territoriality between the pairs (Hildén & Helo 1981).

SITE-TENACITY, HABITAT AND NEST SITES

The Great Grey Owl is a nomadic species, which shifts its breeding areas according to the food situation. Bearing this in mind one can ask, whether it is justified to speak about a separate Finnish population, birds invading Finland from the east in large numbers in certain years and then retiring back again after one or two breeding seasons (Solonen 1986). The species occupies a vast circumpolar range in the northern boreal zone, and it seems to shift the boundaries of its breeding area largely depending on the local vole supply. The abundance of voles both within and

east of Finland probably regulates the movements of the owls in the westernmost parts of the breeding range (Solonen 1987). If the population peak of voles extends over large areas on the Russian side, the nucleus of the species range in Europe, owls need not emigrate to the Finnish side even if there would be a good vole year here. This could explain why Great Grey Owls do not always breed commonly in Finland during mass occurrences of voles. The same holds for invasion birds of the boreal zone in general, e.g. other nomadic owls and crossbills.

How long distances may Great Grey Owls cover when shifting their breeding grounds. Very little is known about this, as the ringing activity has not yet yielded many recoveries. The longest distances recorded so far concern two adult females marked at nest in Norrbotten, Sweden, in 1974 and 1977 and recovered in Finland. The former was controlled breeding in Peokosenniemi, 300 km NE, nine years later in 1983, the latter was found recently dead in Nurmes, 430 km SE, in May 1979. Even much longer movements are quite possible.

Interestingly, the whole population of the Great Grey Owl seems not to be nomadic. Some pairs have been recorded on their territories during poor vole years as well, when they may perform some display and even attempt to nest (Hildén & Helo 1981, Mikkola 1983). Especially on

Swedish side, in Norrbotten, it seems to be a rule that at least some pairs breed, or try to breed, every spring despite poor food supply (e.g. Stefansson 1985, 1986). One could guess that these birds are old, experienced individuals, which are capable of surviving periods of food shortage, at least in years when the crash of voles is not complete. For them, sedentary life may be more advantageous than straggling over long distances in search for better food areas.

The range of breeding habitats accepted by the Great Grey Owl is relatively wide, the two decisive factors being the availability of a suitable nest site and good hunting grounds in the vicinity (Hildén & Helo 1981, Mikkola 1983). The location of the nest may vary from old coniferous forests to clear-felled areas and from uninhabited wilderness to close proximity of houses, and they are almost always situated near open hunting grounds, e.g. marshes, clearings or abandoned fields.

More than 85% of the Finnish nests found were situated in old twig nests of other species, especially those of raptors (Table 1). Because the nests of the most important nest-builders, particularly of the Goshawk Accipiter gentilis, are usually situated in old forests, the large-scale destruction of this kind of habitats by modern forestry must be considered a serious threat to the existence of the Great Grey Owl, in addition to many diurnal raptors (Hildén & Helo 1981, Solonen 1986). On the other hand, the species does benefit from clear-cut areas and abandoned fields, which represent optimal habitats for voles and thus provide excellent hunting grounds for the owls. The area of both these man-made habitats has increased considerably in Finland during the last few decades, which at least partly has counterbalanced the contraction of mature forests.

The Great Grey Owl is more versatile in the choice of nest site than most other owl species (Table 1). This gives a good opportunity to man to improve its present nesting possibilities by constructing artificial nests. The experiences obtained so far in Finland are promising: both twig nests built in trees and open boxes filled with sawdust and nailed on stumps have been accepted by Great Grey Owls (e.g. Hildén & Helo 1981). In this way, the species may be attracted to settle in areas providing good hunting terrain but lacking suitable natural nest sites.

The very different nest sites - in raptor nests, on stumps or on flat ground - used by Great Grey Owls are interesting. Is this merely due to an innate versatility of the species nest site selection? Or are there individual differences between birds, e.g. stump-nesting and ground-nesting owls, as believed by Mikkola (1983)? But if so, are these individual preferences genetically determined or do they develop through imprinting, either during the nestling stage or the first breeding? Individual imprinting on a certain nest site type seems the most likely alternative, but the only way to prove

Table 1.--Distribution of nests of the Great Grey Owl by different sites in Finland (Mikkola 1983, Solonen 1986).

Nest sites	N	%
Twig nests of	213	85.5
<u>Accipiter gentilis</u>	102	50.5
<u>Buteo buteo</u>	38	18.8
<u>A. gentilis/B. buteo</u>	16	7.9
<u>Pernis apivorus</u>	7	3.5
<u>Buteo lagopus</u>	6	3.0
<u>Aquila sp.</u>	4	2.0
<u>Pandion haliaetus</u>	1	0.5
<u>Accipiter nisus</u>	1	0.5
Unknown raptor	6	3.0
<u>Corvus corax</u>	6	3.0
<u>Corvus cornix</u>	3	1.5
<u>Pica pica</u>	3	1.5
Man-made artificial stick nests	9	4.5
	<u>202</u>	<u>100</u>
Stump nests	27	10.8
On flat ground	6	2.4
On cliffs	1	0.4
On a large stone	1	0.4
On a barn roof	1	0.4
Total	249	100

this is through intensive ringing of both breeding adults and young, combined with systematic controlling of breeding owls. It is to hope that we after some years will have more data on this problem.

INVASIONS

If food situation remains good, most Great Grey Owls stay within the breeding area or move only short distances. At irregular intervals, however, they perform large-scale invasions far beyond the limits of the breeding range. As in most irruptive birds, they seem to be caused by the combined effect of overpopulation and food shortage. In peak rodent years the owls raise many young, and when the rodent population crashes most birds are faced with starvation unless they leave the area (Hildén & Helo 1981). In such years of exodus, Great Grey Owls invade Finland from the east and may occur locally in astonishing numbers. The two latest invasions, in 1980/81 and 1983/84, are the largest recorded and fairly well documented, although no detailed analysis have been published so far. In 1980/81, hundreds of birds were reported from different parts of Finland, e.g. c. 40 from the district of Porvoo on the south coast and 70-80 northeast of Kajaani in northern Finland (Hildén & Helo 1981). In these two areas with the most abundant occurrence, the owls were spread over 200-300 km², and most of them were seen close to human habitations.



Photo: Seppo Niiranen

Still higher concentrations were observed in winter 1983/84 in the Helsinki district. More than 60 birds were reported here within an area of c. 175 km², about 90% of them east and south-east of the city, especially on some islands where up to seven birds could be seen at the same time (Niiranen & Haapala 1984). That winter the vole population was very scarce in Finland, and probably the owls had been attracted to the Helsinki area by local occurrences of water voles (*Arvicola terrestris*). The food situation was nevertheless so bad that in early March ornithologists began to feed systematically the owls with laboratory mice. Very soon the owls learned to take advantage of the feeding: from afar they recognized the feeder approaching with a plastic pail in his hand, flew to meet him and perched on a nearby branch to wait. As soon as the mouse was put on the snow, the owl swooped down and seized the prey only a few metres from the observers. The boldest individuals even learned to grab the mouse directly from the feeder's hand! More than 200 mice were given to about 25 owls during a month, until the birds gradually disappeared in early April.

In connection with feeding, twenty Great Grey Owls were captured for ringing in Helsinki (Niiranen & Haapala 1984). Surprisingly, 63% of them were more than one year old, and judging from their weight, the majority were females (14 weighed 1000-1280, average 1160 g). This shows that adults also to a large extent participate in invasions, contrary to the irruptive birds in general in which juveniles usually highly predominate (e.g. Hildén 1974). Owls seem to be an exception to this rule, probably because food shortage often is so complete for vole specialists that most adults also are forced to emigrate. In Tengmalm's Owl *Aegolius funereus*, for instance, about 25% of the stragglers ringed in recent years at the Finnish bird stations have been adults, which is not much less than their proportion in the autumn population. For this species, Korpimäki (1981) has shown that adult males are more sedentary than adult females, which is in good accordance to the small sample of Great Grey Owls ringed in Helsinki.

The large-scale emigrations were formerly fatal for Great Grey Owls. Besides those starving

to death, great numbers of owls were shot, as shown by the statistics of birds sent to taxidermists and museums (cf. v. Haartman et al. 1963-72, Mikkola 1983, p. 209). Fortunately, the attitudes towards owls and raptors have totally changed, both in Finland and most other countries. A good example of this was the successful feeding operation of Great Grey Owls in Helsinki, as well as the positive publicity these magnificent birds gained in mass-media all over the country.

REFERENCES

- v. Haartman, L., Hildén, O., Linkola, P., Suomalainen, P. & Tenovuo, R. 1963-72: Pohjolan linnut värikuvoin. - Otava, Helsinki (in Finnish).
- Helo, P. 1983: Lapinpöllö. - In Hyttiä, K., Kellomäki, E. & Koistinen, J. (eds.): Suomen lintuatlas, pp. 252-253. Lintutieto, Helsinki (in Finnish).
- Henttonen, H. 1986: Causes and geographic patterns of microtine cycles. - Thesis, Dept. Zoology, University of Helsinki.
- Hildén, O. 1974: Finnish bird stations, their activities and aims. - *Ornis Fennica* 51: 10-35.
- Hildén, O. & Helo, P. 1981: The Great Grey Owl *Strix nebulosa* - a bird of the northern taiga. - *Ornis Fennica* 58:159-166.
- Korpimäki, E. 1981: On the ecology and biology of Tengmalm's Owl (*Aegolius funereus*) in Southern Ostrobothnia and Suomenselkä, western Finland. - *Acta Universitatis Ouluensis, Ser A*, 118:1-84.
- Korpimäki, E. 1985: Pöllötutkimus Suomessa. - *Lintumies* 20:57-62 (in Finnish).
- Lehtoranta, H. 1986: Lapinpöllöjen *Strix nebulosa* lähekkäinen pesintä. - *Lintumies* 21:32 (in Finnish).
- Mikkola, H. (1981: Der Bartkauz *Strix nebulosa*. - *Die Neue Brehm-Bücherei* 538-1-124.
- Mikkola, H. 1983: Owls of Europe. - Poyser, Calton.
- Mikkola, H. & Sulkava, S. 1969: On the occurrence of the Great Grey Owl (*Strix nebulosa*) in Finland 1955-68. - *Ornis Fennica* 46:126-131.
- Niiranen, S. & Haapala, J. 1984: Lapinpöllö! - *Lintumies* 19:84-85 (in Finnish).
- Saurola, P. 1985: Finnish birds of prey: status and population changes. - *Ornis Fennica* 62:64-72.
- Solonen, T. 1986: Breeding of the Great Grey Owl *Strix nebulosa* in Finland. - *Lintumies* 21:11-18 (in Finnish with summary in English).
- Solonen, T. 1987: Structure of the Finnish raptor community. - MS submitted
- Stefansson, O. 1985: Projekt Lappuggla. - *Vår Fågelvärld* 44:231-232 (in Swedish).
- Stefansson, O. 1986: Projekt Lappuggla. - *Vår Fågelvärld* 45:301-302 (in Swedish).

Territorial Aspects of Barred Owl Home Range and Behavior in Minnesota¹

Thomas H. Nicholls² and Mark R. Fuller³

Abstract.--We described the movements of barred owls (*Strix varia*) based on samples taken from millions of telemetry data recorded by a semi-automatic radio-tracking system. Evidence collected convinces us that barred owls are territorial in habit. They exhibited nearly exclusive use of their home ranges within their own species. When home ranges of neighboring owls did overlap, it was of short duration and consisted of a small portion of the total home range. However, home ranges of mated pairs overlapped extensively. Home range boundaries were generally constant from year to year and decade to decade, even when occupants changed. Neighbors were seldom near each other. Vocal advertisement was apparently the most important display. The few barred owls that did not exhibit territoriality were thought to be young, or dispersing birds.

INTRODUCTION

Territoriality in birds and animals has been addressed by many authors who have variously defined the term and recommended different criteria for determining territories and territorial behavior. The most commonly accepted definition of a territory is: A fixed area that varies little through time, from which rivals are excluded, and in which the occupant conducts some or all of its activities (Brown 1975, Morse 1980, Wittenberger 1981).

Given this definition, several workers have reported territorial behavior by various species of owl: great horned owl, *Bubo virginianus* (Miller 1930, Baumgartner 1939); flammulated screech owl, *Otus flammeolus* (Marshall 1939); snowy owl, *Nyctea scandiaca*, (Keith 1964, Evans 1980); and tawny owl, *Strix aluco* (Southern 1970, Southern and Lowe 1968). To further support the concept of territoriality among owls, we present

the results of our studies on the home ranges and movement patterns of the barred owl, *S. varia*. (We define "home range" as that area regularly used by an owl during its normal activities of hunting, courtship and mating, nesting, caring for young, and seeking shelter.) We conducted our two studies on the Cedar Creek Natural History Area (CCNHA) in Minnesota. We used radio telemetry to track the birds. This permitted short sampling intervals, useful for evaluating the short-duration activities of owls necessary to describe territoriality.

METHODS

The CCNHA, a 5,460-acre research facility operated by the University of Minnesota, is located at 93° 12'E longitude and 45° 24'N latitude about 30 miles north of Minneapolis, Minnesota. The area contains a blend of forests, prairies, marshes, lakes, ponds, and abandoned fields of various ages (Pierce 1954, Bray et al. 1959). Nicholls and Warner (1972) described the general seasonal and phenological characteristics related to barred owl habitat use.

Owls were trapped using baichatri traps, Swedish goshawk traps, and two-shelf mist nets (Nicholls 1973, Fuller and Christenson 1976). Owls were measured, sexed when possible, fitted with radio transmitters (Nicholls and Warner 1968, Fuller 1979), banded, and released (fig. 1). We concluded that birds were a pair if they cared for the same young owls during the breeding season.

¹Paper presented at the symposium, Biology and Conservation of Northern Forest Owls, Feb. 3-7, 1987, Winnipeg, Manitoba. USDA Forest Service, General Technical Report RM-142.

²Thomas H. Nicholls, Project Leader, Wildlife Habitat Research, United States Department of Agriculture, Forest Service, North Central Forest Experiment Station, 1992 Folwell Ave., St. Paul, Minnesota 55108, USA.

³Mark R. Fuller, Ecologist, Patuxent Wildlife Research Center, Laurel, Maryland 20708, USA.



Figure 1. A barred owl equipped with a radio transmitter completely covered by feathers.

The owls were tracked by a semi-automatic radio-tracking system developed by Cochran et al. (1965). The system consisted of two rotating directional receiving antennas on towers about half a mile apart. Each owl's transmitter operated at a different frequency. Signals were received at a central laboratory every 45 seconds, providing a maximum of 1,920 daily locations determined by azimuth triangulation. Received signals were recorded on film and transcribed to computer tape for data analyses.

Nicholls (1973) radio-tracked 10 barred owls during 1965 and 1966, sampling more than 28,000 owl locations from more than two million locations recorded. The sampling interval was normally every 15 minutes at night and every 30 minutes during the day. Fuller (1979) radio-tracked four barred owls from 1971 to 1973, sampling every minute every-other-day, and every 15 minutes on the alternate days. In both studies, locations sampled while an owl was in flight were not used because such location data are subject to error.

Home range was determined by overlaying the study area map with a grid of 2,080, 1.6-acre squares. Square size was based on error factors that influence the accuracy of location data obtained by the triangulation method (Fuller 1979). Squares were numbered for computer identification. Using degree bearings obtained from the two radio tracking towers, a computer program assigned each location to a 1.6-acre square. Proximity of birds was based on the number of grid squares (about 264 ft on a side) separating their locations.

Nicholls (1973) determined home range size by summing the total number of squares within the home range boundary delineated by the outermost 1.6-acre squares with owl locations in them (fig. 2). Those few squares without owl locations but inside home range boundaries were considered part of the home range. Fuller (1979) used a similar method, the "grid square plus fill" method (Rongstad and Tester 1969) that was also based on the 1.6-acre grid system. When the computer scanned across the grid, it included squares in the home range even if they did not contain locations when they were between locations separated by not more than five squares along either the vertical or horizontal axis. These methods include a conservative number of squares that an owl might have utilized or flown over.

Useful home range data were obtained for 13 of 17 barred owls radio-tracked (table 1). The home ranges of nine barred owls that Nicholls (1973) radio-tracked from 7 to 28 weeks ranged from 213 to 912 acres. The home ranges of four owls that Fuller (1979) studied from 3 to 30 weeks ranged from 309 to 1,903 acres. The average home range size for these 13 owls was 676 acres based upon 249,623 owl locations.

RESULTS AND DISCUSSION

Overlap of adjacent owls' home ranges

We found four cases of neighboring owls not sharing any parts of their home range during radio-tracking and several examples of brief and limited use of common area by neighbors (table 2). Historically, the exclusive or nearly exclusive use of space, has been a key element of the territory concept (Brown 1975, Wittenberger 1981). No home range overlap was detected among three barred owls tracked in 1965 (fig. 3) or among two owls studied in 1972 (fig. 4). Spatial patterns alone are not evidence of territorial behavior, but territorial behavior tolerates little or no overlap of home ranges (Brown 1975).

Simultaneous radio-tracking of barred owl 709, 710, and 714 revealed limited overlap of their home ranges (fig. 5). Owl 709 spent over 98 percent of its time north of the county road and 714 spent all of its time south of the county road. There were only 11 acres of overlap between the adjacent home ranges of male 710 and male 714 and only 3 acres of overlap between owl 709 and male 710 (table 2 and fig. 5). Some authors maintain that the exclusive use of an area is required for it to be considered a territory, but Brown (1975) claims the important thing is that intruders are driven from a territory when encountered. If a home range includes limited resources (e.g. food, nest site, shelter), neighbors will sometimes enter another's territory.

How often and how long owls share a territory is revealed in another example. An intensive sample of locations from non-breeding female 730

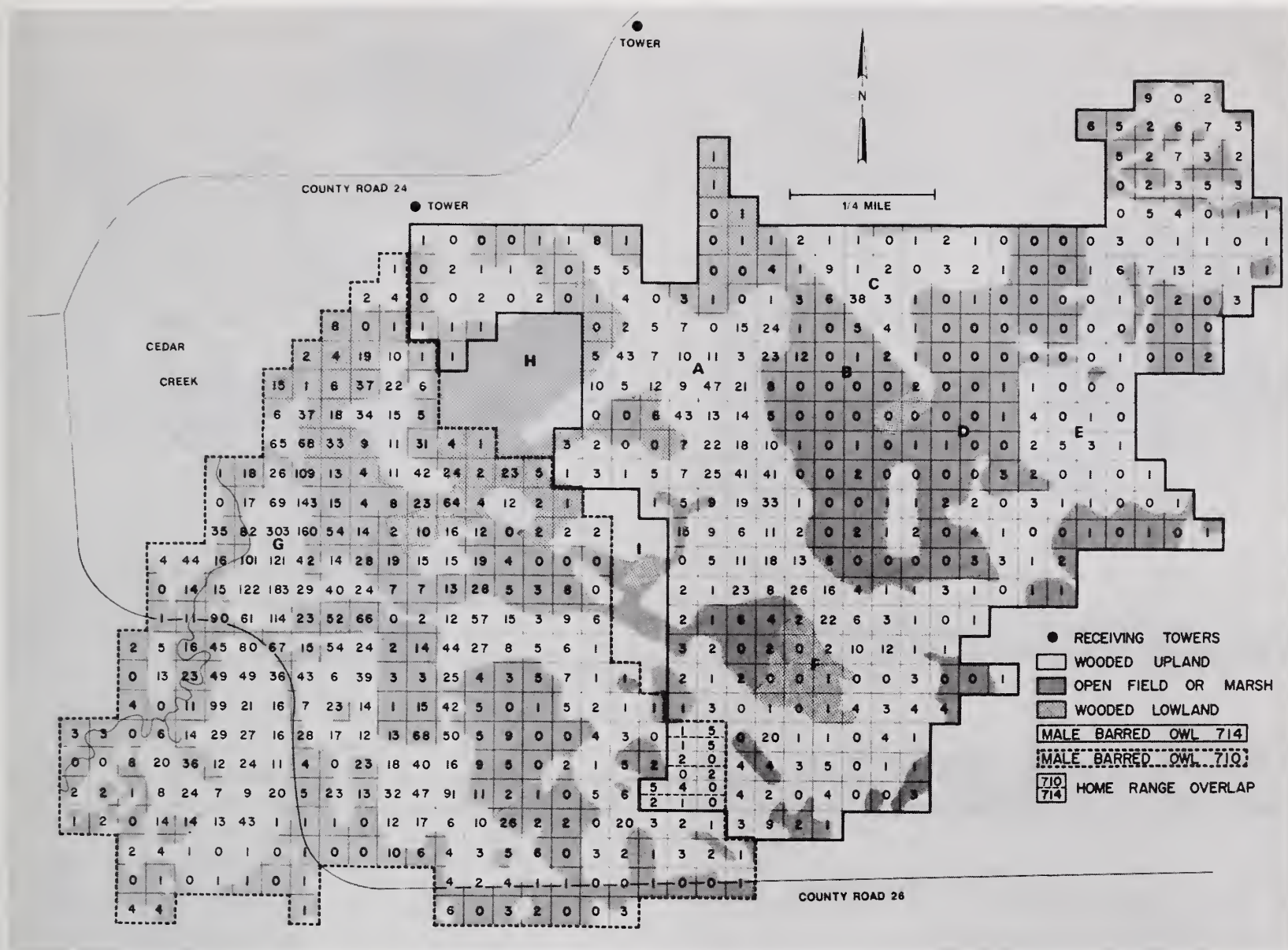

Figure 2. The 502-acre home range of male 710 from March 10 to September 11, 1966, and the 611-acre home range of male 714 from March 22 to October 4, 1966, on the Cedar Creek Natural History Area. Each square is 1.6 acres; numbers in squares indicate the number of radio locations. Note territorial boundary and 11-acre home range overlap where territorial displays were observed.

in 1973 showed parts of her weekly home ranges were interspersed with those of a breeding pair. She was detected in one or more of the same grid squares that were used by male 731 in 12 of 14 weeks of simultaneous radio-tracking, but these two owls were never detected closer than 1,319 ft to each other. However, non-breeding female 730 did range near the mate of 731, breeding female 720b. The closest they were detected was 528-791 ft for 6 minutes. They were also recorded within 1,319 ft of each other over a 4-week period for 82 minutes. The total time spent within 1,319 ft of each other totaled 0.01% of the 4 weekly periods when proximity was detected. These two females shared 1.5 - 7.9 acres (average 4.2 acres) in 10 of 14 weeks. This shared area included 1.4 - 68.0% of the weekly home range of the breeding owl and 0.7 - 5.8% of the weekly area used by the non-breeding bird.

Thus, our evidence suggests that individuals spend at most only a small percentage of their time within the range or in proximity to neighbors. Trapping results, positions of owl vocalizations, and observations of owls led us to assume that no other owls (except mates) established home ranges in the areas used by the radio-marked birds. A few examples of movements by owls that did not establish home ranges (documented in the Non-territorial birds section) also support this assumption.

Home range overlap of mated owls

We found extensive overlap between members of the two barred owl pairs we radio-tracked. Female 702 and her mate, male 714, were trapped in the same mist net in March 1966. During the next 2

Table 1.--Home Ranges of barred owls on the Cedar Creek Natural History Area, Minnesota.

Barred ¹ Owl	Home Range (Acres)	No. Owl Locations	Period Radio-Tracked
701	213	2,132	5/19/65 - 8/9/65
702	515	943	3/22/66 - 5/19/66
703	258	2,479	7/15/65 - 9/20/65
704	768	4,746	11/12/65 - 2/13/66
707	809	1,705	2/15/66 - 8/15/66
709	912	5,959	2/23/66 - 9/11/66
710	502	5,043	3/8/66 - 9/11/66
712	493	2,213	3/14/66 - 5/5/66
714	611	1,345	3/22/66 - 10/4/66
717b	309	40,148	5/25/72 - 8/3/72
720a	901	18,085	6/29/72 - 8/31/72
720b	474	43,878	3/8/73 - 6/7/73
730	1,903	86,830	2/27/73 - 9/4/73
731	793	34,117	3/7/73 - 6/6/73

TOTALS
13 \bar{X} = 676 249,623

¹Owls radio-tracked by Nicholls (1973) = 701 to 714
Owls radio-tracked by Fuller (1979) = 717b to 731

Table 2.-- Some home range relationships of barred owls on the Cedar Creek Natural History Area, Minnesota, during 1965 and 1966. (F = Female, M = Male)

Owl Number	Number acres overlap between home ranges	Radio-tracked at same time	Comments
701F 703	0	Yes	701 occupied home range south of 703
709 710M	3	Yes	710 occupied home range south of 709
702F 710M	3	Yes	710 occupied home range west of 702
714M 710M	11	Yes	710 occupied home range west of 714
704M 710M	16	No	710 occupied home range west of 704
709 702F	102	Yes	709 occupied home range northwest of 702
709 714M	136	Yes	709 occupied home range northwest of 714
701F 710M	199	No	701 was suspected mate of 710
702F 704M	449	No	704 was suspected mate of 702 before he died
702F 714M	467	Yes	702 and 714 were paired
714M 704M	558	No	714 took over 704's home range after he died

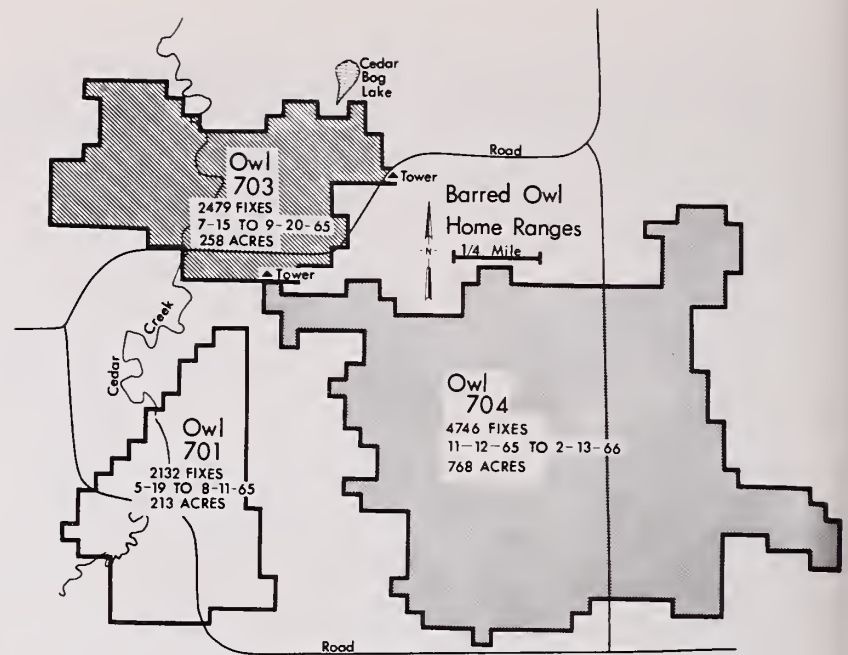

Figure 3. The geographical locations of home ranges occupied by female 701, 703 (sex unknown), and male 704, mostly studied in 1965, were territorial and showed no overlap in their home ranges.

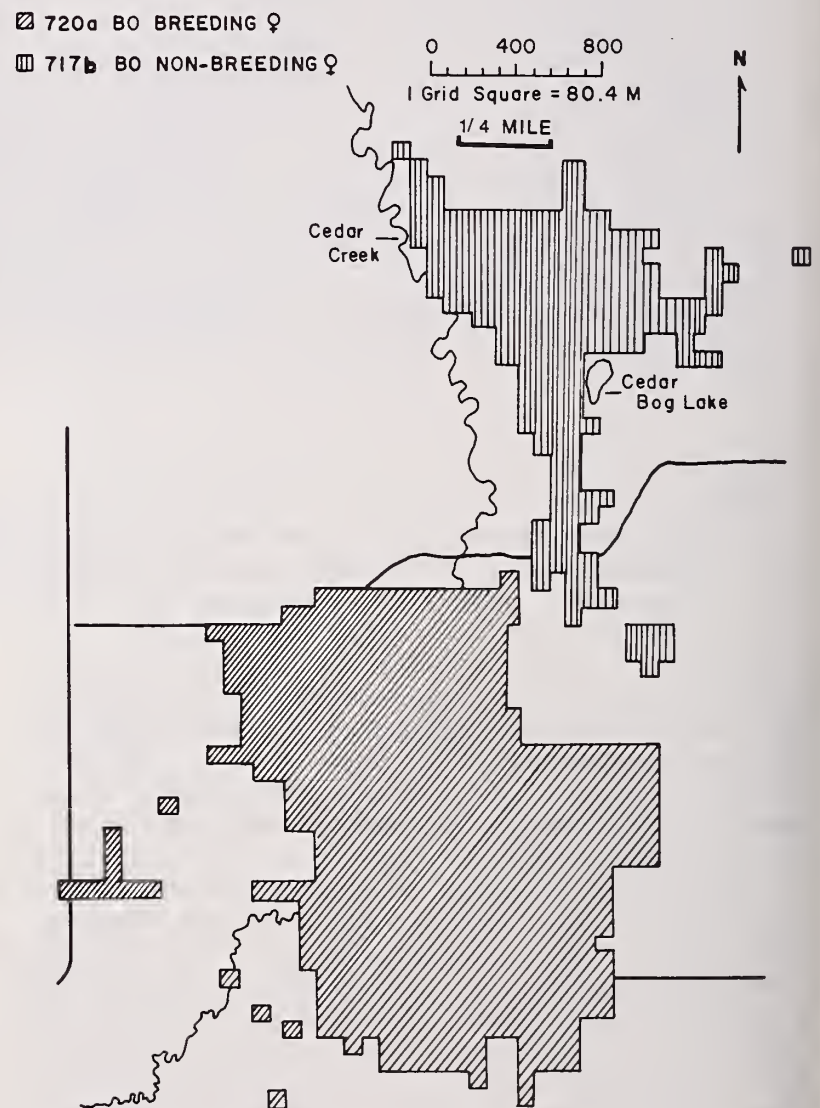

Figure 4. Non-breeding female owl 717b (studied from May 25 to August 3, 1972) and breeding female 720a (studied from June 29 to August 31, 1972) were territorial and showed no overlap in their home ranges.

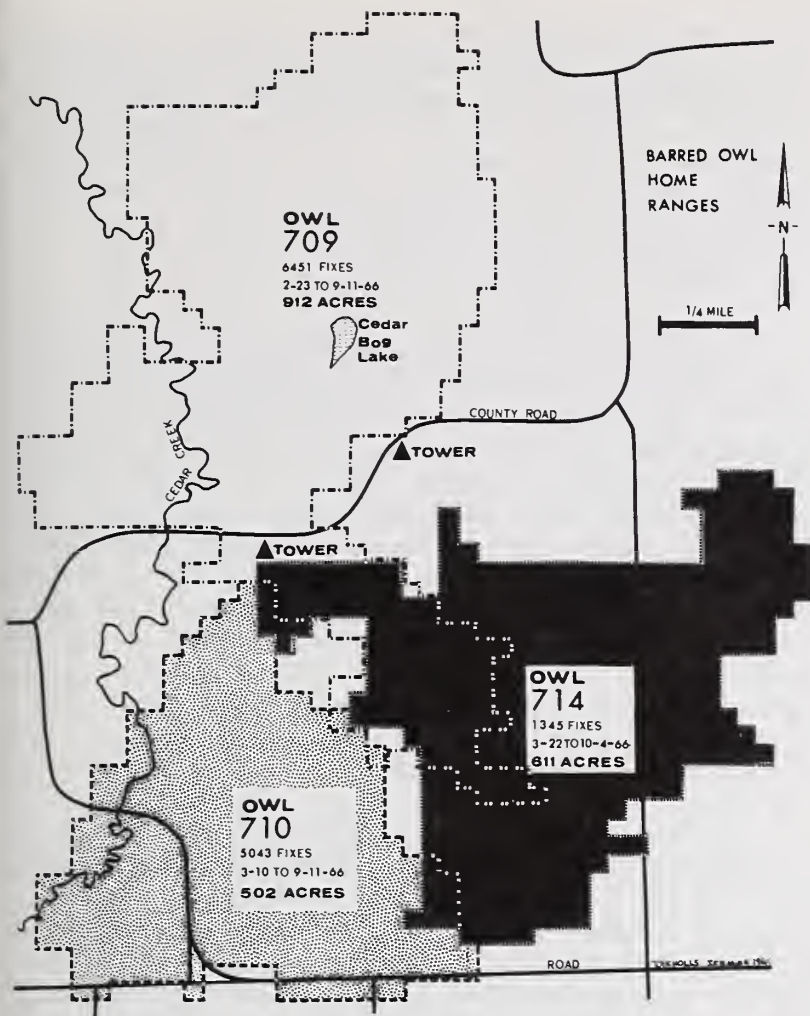

Figure 5. Home ranges of barred owl 709, male 710, and male 714 showed that all three owls had little overlap of their home ranges. The small overlap of 709's home range into 714's was a result of a few brief trips into 714's home range. Vocal territorial displays were documented in the overlap area.

months, 87% of the female's total range (449 of 515 acres) was within the area used by her mate (fig. 6a). Similarly, more than 95% of the range of female 720b was shared with her mate, 731, from March to June in 1973 (fig. 6b). Females of many monogamous species do defend territories (Morse 1980). Southern (1970) found that female tawny owls joined their mates in displays at territory boundaries. An energy-efficient strategy for two birds would be to defend the same boundary, within which there were just enough resources to support both of them (Brown 1975). The size of the territory depends mainly on the type(s) of resources to be defended and the ultimate factors influencing the behavior (Wittenberger 1981).

Persistence of boundaries

Our maps of radio-locations showed that home range positions on the study area remained similar during 2 consecutive decades. Barred owls do not use all of their home range each night, or each week, but after several weeks, the core areas are re-used and few boundary changes occur (Nicholls 1973, Fuller 1979). Barred owl areas of use thus meet the fixity criterion for territoriality (Brown 1975).

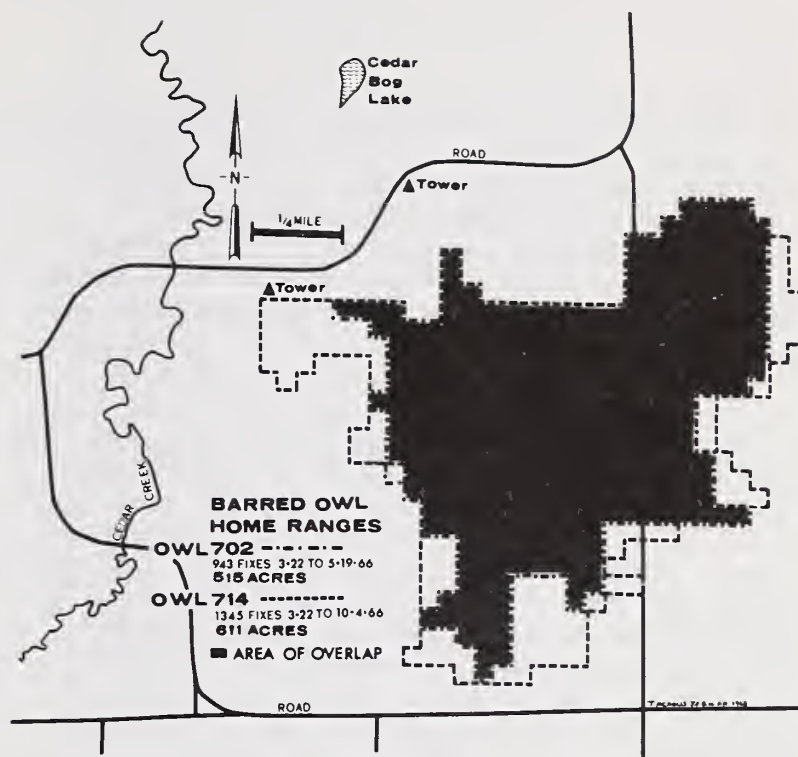

Figure 6a. Overlapping home ranges of a pair of barred owls, female 702 and male 714, during 1966.

- ▨ 720b BO BREEDING ♀
- ▩ 731 BO BREEDING ♂
- = Nest

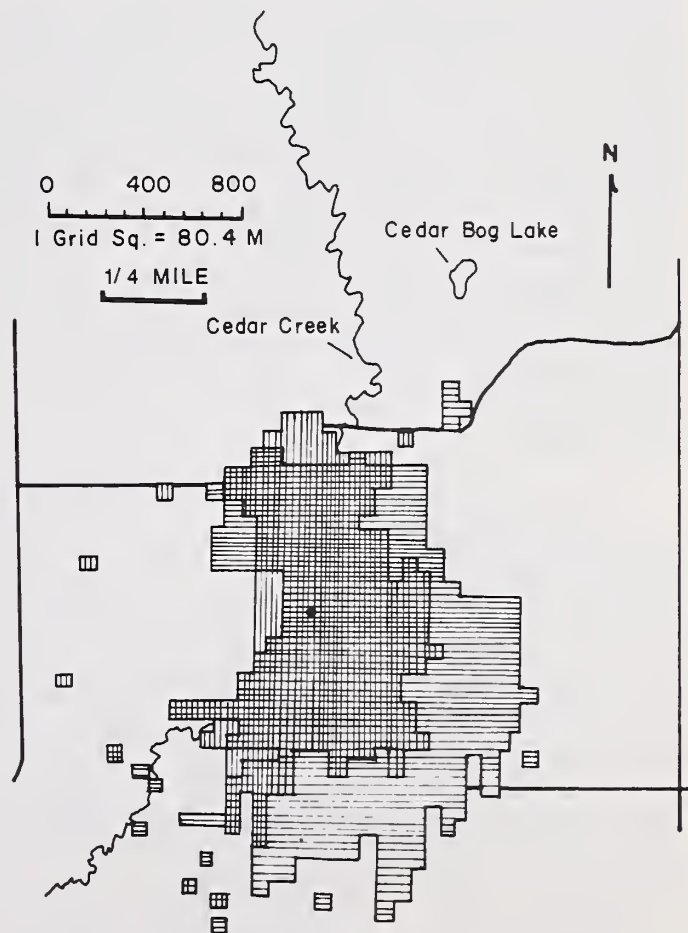

Figure 6b. Overlapping home ranges of a pair of barred owls, female 720b and male 731, during 1973.

We had two cases in which a female owl (720 and 702) used much of the same area in consecutive years (figs. 4 and 6a). Even when a new bird replaced a previous occupant, home range boundaries remained similar. For example, male barred owl 704 died and was replaced by male 714. During the next 6 months, 72% of 714's range was the same area used by 704 (figs. 3 and 5). Similarly, from December 1971 to August 1972, female 717 occupied the area north of the county road then, after the disappearance of 717, female 730 was radio-tracked in that area from February through August 1973.

Comparing maps from the 1960's with those from the 1970's shows that similar boundaries persisted from one decade to the next. In the 1970's, barred owls also did occupy the area used by 704 and 714, but they were not radio-tracked. Southern (1970) documented constancy of tawny owl boundaries for 13 years, and noted that for long-lived birds (e.g. survival of > 4 years for individuals surviving to maturity), territory boundaries probably remain fairly constant, assuming resource distribution does not change appreciably. It is unlikely both members of a pair, or neighbors, die at the same time, thus, one territory holder will remain to maintain the boundary.

Vocalizations related to territoriality

Our experience suggested that owls vocally communicate with their mates, delineate their territory, and signal its occupancy. Vocalizations often advertise the presence of territorial birds (Wittenberger 1981). Baumgartner (1939) reported great horned owls making a circuit, associated with calling, around their "domains." We often heard two to four barred owls calling in sequence. These calls came from locations that formed a pattern similar to the pattern of home ranges based on telemetry. The calling from within home ranges, in conjunction with a few documented instances of vocal displays at home range boundaries, is additional evidence of territorial behavior. Southern (1970) obtained similar results with tawny owls.

The first boundary encounter involved two barred owls that were heard hooting about 0.8 mi apart at 1400 hours on, March 4, 1966 in the vicinity of the boundary between the the home ranges of owls 710, 702 and 714 (fig. 2). The hooting continued and the owls perched closer and closer until they sounded to be within about 15 yards of one another. Hooting became frequent, and loud calls, similar to those reported by Bent (1938), were heard. After about 10 minutes, the owls retreated toward the center of their ranges. Hooting was heard later from the positions where the owls were initially detected.

Another bout of vocalization occurred in the same vicinity at 0910 hours on March 21, 1966. The owls were already within a few yards of each

other and calling several times a minute. There were frequent flights back and forth, but there was no indication that the birds made physical contact. The positions of the calls suggested a chase and retreat behavior. After 20 minutes all hooting stopped. The home range maps of male owls 710 and 714 revealed a definite boundary with only an 11-acre overlap in the area where the vocalizations were heard (fig. 2).

Evidence of expulsion of an intruder was gathered between 1930 and 2200 hours on April 28, 1966. Loud caterwauling, as described in Bent (1938), was heard; radio-telemetry data suggested the birds doing the hooting were paired owls 702 and 714 (fig. 6a). Subsequently, a third owl, 709 (fig. 5), was heard nearby and the first two flew toward the newcomer. It quickly retreated and the interaction ended. After this encounter, owl 709 did not enter the range of owls 702 and 714 for at least 20 days. Then, between May 19 and June 8 it made two brief trips into their range. From June 8 until September 11, 1966, owl 709 never reentered the area used by 702 and 714.

A tape recording of barred owl calls was played within the territory of 702 and 714 on May 4, 1966 at 2200 hours to see if the pair would respond to another owl within their territory. Within 12 minutes both owls responded by hooting, flying toward the tape recorder, and landing in trees overhead. Human imitations of a barred owl hoot elicited a response from owl 710 in his nest area on several occasions. Subsequently, broadcasts and human imitations of barred owl vocalizations have been used to attract owls to mist nets for capture and radio-marking on the CCNHA (Kuechle et al. in press), and barred owl calls have been used to elicit responses for surveys (Fuller and Mosher 1981, McGarigal and Fraser 1985). Miller (1930) imitated great horned owl vocalizations and attracted owls to boundaries but could not induce them to cross into a neighbor's range. Vocalizations and sometimes chasing are apparently the ways barred owls establish and defend their territories.

Non-territorial birds

Some barred owls did not exhibit territorial behavior. These birds were thought to be young or dispersing birds that moved into the study area and could not successfully establish territories. For example, owl 729 was radio-tracked from January to April, 1973, and used the area along the eastern edge of the range of 730, the north and east edges of the ranges of pair 720-731, and the area east of this pair's range that was used by unmarked barred owls. In April, 729 moved to the northeast and eventually out of the study area. Owl 712 also left the area after being radio-tracked for 52 days from March 14 to May 17, 1966. This behavior suggests resident holders enforce a degree of exclusive use of certain areas within their established home ranges and that there are "homeless" owls searching for an area to settle in. Settling behavior was documented for

tawny owls by Southern (1970); other observations and experiments with territorial species have demonstrated the existence of "floaters," waiting to establish territories (Davies 1978).

CONCLUSION

Our studies revealed that barred owls maintain nearly exclusive home ranges, expel intruders and neighbors from their ranges, and vocalize to advertise the occupancy of their space. These behaviors are consistent with criteria for territoriality. Territorial behavior that leads to nearly exclusive use of space has a variety of advantages for occupants (Brown 1975). Apparently, nearly all the barred owls' activities occurred in their territories, which corresponded with their home ranges. This relationship is the Type A territory of Hinde (1956).

Hinde discussed many potential advantages for territory holders: protection of nest and nest site, prevention of epidemics, reduction of loss to predation for cryptic species, prevention of inbreeding, facilitation of pair formation and maintenance, prevention of interference with reproductive activities, and exclusive use of limited resources, including short-term requirements of the occupant (e.g. food for young). Being territorial, the barred owl benefits from many of these advantages.

ACKNOWLEDGMENTS

Studies of the kind we undertook required the help of many individuals over a long period of time. We extend thanks to the staff and colleagues who assisted us at the University of Minnesota CCNHA and the Department of Ecology and Behavioral Biology. We especially acknowledge Drs. Dwain W. Warner, William H. Marshall, and John R. Tester, who served as advisors. The authors wish to thank J. Faaborg, J.D. Fraser, D.H. Johnson, and A.R. Weisbrod for reviewing this paper and providing many helpful comments for improvement.

LITERATURE CITED

- Baumgartner, F.M. 1939. Territory and population in the great horned owl. *Auk* 56:274-282.
- Bent, A.C. 1938. Life histories of North American birds of prey. (Part 2). United States National Museum Bulletin 170. 482 p.
- Bray, J.R., D.B. Lawrence, and L.C. Pearson. 1959. Primary production in some Minnesota terrestrial communities for 1957. *Oikos* 10 (pt. 1):38-49.
- Brown, J.L. 1975. The evolution of behavior. W.W. Norton and Co., Inc. New York. 761 p.
- Cochran, W.W., D.W. Warner, J.R. Tester, and V.B. Kuechle. 1965. Automatic radio-tracking system for monitoring animal movements. *BioScience* 15:98-100.
- Davies, N.B. 1978. Ecological questions about territorial behavior. p. 317-350. In Behavioral ecology, an evolutionary approach, J.R. Krebs and N.B. Davies, eds. Sinauer Associates Sunderland, Massachusetts.
- Evans, D.L. 1980. Vocalizations and territorial behavior of wintering snowy owls. *American Birds* 34:748-749.
- Fuller, M.R. 1979. Spatiotemporal ecology of four species of sympatric raptor species. Ph.D. Thesis, 220 p. University of Minnesota.
- Fuller, M.R., and G. Christenson. 1976. An evaluation of techniques for capturing raptors in east-central Minnesota. *Raptor Research* 10:9-19.
- Fuller, M.R., and J.A. Mosher. 1981. Methods of detecting and counting raptors: a review. p. 235-246. In C.J. Ralph and J.M. Scott, eds. Estimating numbers of terrestrial birds. *Studies in Avian Biology* No. 6. 630 p.
- Hinde, R.A. 1956. The biological significance of territories of birds. *Ibis* 98:340-369.
- Keith, L.B. 1964. Territoriality among wintering snowy owls. *Canadian Field Naturalist* 78:17-24.
- Kuechle, V.B., R.A. Reichle, R.J. Schuster, and G.E. Duke. Telemetry of gastric motility data from owls. In Proceedings of 9th international symposium on biotelemetry. International Society on Biotelemetry. University of Nijmegen, Department of Physiology, Nijmegen, Netherlands. In press.
- Marshall, J.T., Jr. 1939. Territorial behavior of the flammulated screech owl. *Condor* 41:71-78.
- McGarigal, K., and J.D. Fraser. 1985. Barred owl responses to recorded vocalizations. *Condor* 87:552-553.
- Miller, L. 1930. The territorial concept in the great-horned owl. *Condor* 32:290-291.
- Morse, D.H. 1980. Behavioral mechanisms in ecology. Harvard University Press, Cambridge, Massachusetts. 383 p.
- Nicholls, T.H. 1973. Ecology of barred owls as determined by an automatic radio-tracking system. Ph.D. Thesis, 163 p. University of Minnesota.

Nicholls, T.H., and D.W. Warner. 1968. A harness for attaching radio transmitters to large owls. *Bird Banding* 39:204-214.

Nicholls, T.H., and D.W. Warner. 1972. Barred owl habitat use as determined by radio-telemetry. *Journal of Wildlife Management* 36:213-224.

Pierce, R.L. 1954. Vegetation cover types and land use history of the Cedar Creek National History Reservation, Anoka and Isanti Counties, Minnesota. M.S. Thesis, 137 p. University of Minnesota.

Rongstad, O.J., and J.R. Tester. 1969. Movements and habitat use of white-tailed deer in Minnesota. *Journal of Wildlife Management* 33:366-379.

Southern, H.N. 1970. The natural control of a population of tawny owls. *Journal Zoological London* 162:197-285.

Southern, H.N., and V.P.W. Lowe. 1968. The pattern of distribution of prey and predation in tawny owl territories. *Journal of Ecology* 37:75-97

Wittenberger, J.F. 1981. *Animal social behavior*. Duxbury Press, Boston. 722 p.

Barred Owls and Nest Boxes — Results of a Five-Year Study In Minnesota¹

David H. Johnson²

Abstract. Thirty-six nest boxes were monitored 5 years to evaluate Barred Owl (*Strix varia*) nesting biology, habitat characteristics, and box design and placement. Boxes were erected in 1981 and 1982, and were placed at least 1.6 km apart in various forest habitats. Fourteen boxes used by owls for 1-3 seasons produced 22 nestings (12.4% overall nest box use), with 86% of nesting attempts successful. Predominant nesting use occurred in the northern hardwood forest type. Habitat evaluation surrounding the 14 active boxes and 10 additional nest sites (8 natural cavities, 2 nest boxes) included 0.04 ha and 314 ha circular plots. Recommendations include using a topless nest box or one with a side entrance hole of \geq 18 cm diameter. Box placement should avoid raccoon (*Procyon lotor*) travelways, be 7 m above ground, and allow easy in-flight access.

INTRODUCTION

The Barred Owl is a close relative of the European Tawny Owl (*S. aluco*) and Ural Owl (*S. uralensis*), and the North American Spotted Owl (*S. occidentalis*). As such, some similar natural history characteristics should apply between these species. Like Tawny and Ural owls, Barred Owls have been found to nest in artificial nest cavities (Rubey 1927, Johnson 1980, Snyder and Drazkowski 1981, Follen 1982, Johnson and Follen 1984). The availability of suitable nest sites is reported to be a limiting factor for cavity nesting species (Thomas et al. 1979). Current forest management directives promote short rotations and intensive culture, which reduce the numbers of existing or potential nest sites. The Barred Owl is a relatively common owl in Minnesota, and has recently been viewed as an ecological indicator species for the management of mature/old

growth forests. This study was conducted as part of an overall research effort into Barred Owl ecology in the state. Herein I provide information on nest boxes, their use by owls and other wildlife, and an overview of habitat conditions surrounding used nest sites.

STUDY AREA AND METHODS

The study area involved Hubbard, Becker, Cass, and Crow Wing counties in north-central Minnesota (1,336,600 ha). This area lies primarily at 47 degrees North latitude, averages 64 cm of precipitation annually, and has a 125 day growing season. Snow covers the ground an average of 130 days per winter. The terrain is typically level to slightly rolling. Water is relatively abundant with around 2000 lakes and rivers totaling approximately 200,000 ha (15% total land area). Forests in this region cover some 796,000 ha (60% total land area) (Jakes 1980) and consist primarily of 50 to 80 year old mixed and pure stands of aspen (*Populus* spp.), oak (*Quercus* spp.), maple (*Acer* spp.), basswood (*Tilia americana*), paper birch (*Betula papyrifera*), elm (*Ulmus* spp.), black ash (*Fraxinus nigra*), and jack pine (*Pinus banksiana*). Widespread logging and slash burning during the late 1800's and

¹Paper presented at the symposium, Biology and Conservation of Northern Forest Owls, Feb. 3-7, 1987, Winnipeg, Manitoba. USDA Forest Service General Technical Report RM-142.

²permanent address: RR 6 Box 410, Mankato, MN 56001.

early 1900's has resulted in an even-aged forest in which natural cavities are scarce. The predominant land use is logging, followed by agriculture (dairy, corn, wheat, potatoes) and tourism.

Boxes were placed in what was viewed as potentially suitable owl habitat, based on the literature and experience. Pre-placement surveys were not conducted. Boxes were of two types: a covered box with an entrance hole of approximately 18 cm diameter (n = 34) or a topless box (n = 2). All were made of 2 cm thick unpainted/untreated wood and measured roughly 29 x 26 x 55 cm (inside length x width x depth). All boxes were placed from 4.11-10.87 m (\bar{x} = 6.14 m) above ground on living trees 16.5-63.5 cm dbh (\bar{x} = 37.1 cm), and were mounted with either the back (n = 8) or a side of the box (n = 28) immediately adjacent to the tree trunk/branch. See Johnson and Follen (1984) for box design and mounting details. Twenty-eight (28) boxes were placed on deciduous trees and 8 boxes on coniferous trees. Entrance hole orientation depended on anticipated owl flight access. Approximately 5 cm of small wood chips or leaf material was maintained in the boxes as nesting substrate.

Boxes were erected prior to the breeding seasons of 1981 or 1982. Three or more inspections were made yearly; the first during early January (done primarily to clean out leaf material put in the preceeding fall by dispersing squirrels), the second and third done in early April and mid-May respectively, to check for nesting activity. Additional checks were made if owls were nesting. Climbing irons, belt, and rope were used throughout the project to scale the trees.

Nest site habitat data were collected at 24 separate Barred Owl nest sites during the leaf-free season following the first nesting use. These sites included 14 of my nest boxes, 2 other nest boxes, and 8 natural cavities. Two types of circular plots were employed: a 0.04 ha (11.3 m radius) plot and a 314 ha (1 km radius) plot. Both were centered on the nest tree. Table 2 lists 15 quantitative habitat variables that were either measured directly or created by aggregate at the 0.04 ha plots. Sampling procedures were similar to those as described in James and Shugart (1970) and Titus and Mosher (1981). Habitat evaluation also included recording the nest tree species, box mounting style, entrance hole compass orientation, and forest type within 100 m of the nest site.

Seven (7) habitat types were measured at the 314 ha plots: forest, water, upland brush/upland and lowland grass, marsh, agricultural fields, lowland brush, and roads. Types were interpreted to the nearest 0.4 ha from 1:15,840 black and white infra-red aerial photos, copied onto frosted matex overlays, and hectarized via a dot grid.

RESULTS

Box Use by Owls

Fourteen (14) boxes (12 covered and 2 topless) were used by owls for nesting a total of 22 times (12.4% overall nest box use). An additional 4 boxes were recorded as having owl visitation. Seven (7) boxes were used only once for nesting, 6 boxes two times, and 1 box three times (Table 1). Nineteen of 22 nests (86%) were successful in raising young to or beyond the "brancher" stage (i.e. 25-30 days old). At the 19 successful nests, 52 eggs (2.73/clutch, range 2-4) produced 46 young (2.42/nest, range 1-4). Three (3) nests were predated by raccoons, 2 at the egg stage (box 25, 1983 and 1984), and 1 with approximately 15 day-old young (box 21). I feel that I was the cause of predation at the two nests lost at the egg stage (raccoons followed scent trail). No re-nesting attempts were made at any of the unsuccessful nests.

Table 1. Barred Owl nesting activity in boxes.

Box#	1981	1982	1983	1984	1985	1986
1	4/4*	2/1	-	-	-	-
43	3/3	-	-	2/2	-	-
44	3/3	-	-	-	-	-
3	4/3	-	-	-	-	-
8	-	2/2	2/2	-	-	-
15	-	3/3	-	-	-	-
19	-	-	3/3	3/2	-	-
21	-	-	3/0	-	-	-
22	-	-	-	3/3	-	-
25	-	-	2/0	2/0	2/2	-
33	-	-	2/2	-	-	-
34	-	2/2	-	-	-	3/3
36	-	-	-	-	-	3/2
45**	-	-	3/2	3/2	-	-

* number of eggs laid/number of yng. raised.
 ** box #45 was available for use only 4 years.

As indicated in Table 1, owl nesting activity in the boxes was rather staggered. Although no detailed records were kept, pairs were often seen on their territories during the non-nesting years (via territorial responses to taped calls and observations of delayed courtship

activities). It is my opinion that the sporadic nesting recorded was the result of fluctuating food sources, rather than the undocumented use of alternate (and unknown) nest sites.

It is of interest to note that at one box, occupancy by owls was relatively quick after box placement. Box 45 was erected on 04-02-83 and owls had eggs in it by 04-09-83.

During fall dispersal, squirrels often placed 25-30 cm of leaf and twig material into the boxes. In 2 instances, owl visitation (but no nesting) was noted when this deep, rather loose leaf matter was in the box.

In a third case the owls did appear to compact and nest on this leaf material.

Four boxes were placed within 100 m of four pre-existing nest sites, to offer an alternate nest site. Boxes 1 and 3 were placed near natural cavities, 30 and 36 were placed near topless wood duck boxes. In three of the four cases, owls

moved into the box I provided; details as follows. The natural cavity near box 1 was a 2 m vertical trunk split in a live basswood tree. The tree cavity was deteriorating and although the birds nested there in 1977 and 1978 they did not use it thereafter. In 1981 and 1982 nesting at this site occurred in box 1.

The natural cavity near box 3 was a hollow branch stub in a live basswood tree. This nest site began when a 23 cm branch was cut off in 1965, subsequent callus growth and interior rot developed the nest cavity. Wood ducks (*Aix sponsa*) nested here 1975-1979, and owls in 1980. The owls used nest box 3 in 1981. Owls with young were heard for an extended period approximately 300 m from the box in 1983, and likely reflect the nesting use of a third (but unlocated) nest site.

The topless wood duck box near box 30 was used for nesting in 1980, 1981, and 1984. Although it was not used for nesting, owl visitation was recorded for box 30.

The topless wood duck box near box 36 was used for nesting only in 1980 and 1981. In 1986 owls nested in box 36.

Table 2. Description of quantitative habitat variables measured at 22 Barred Owl nest sites.

Mnemonic	Description
1. HTNSTTRE	height of nest tree in meters
2. DBH	diameter at breast height of nest tree in cm
3. CAVHT	above ground height of cavity in meters
4. CANHT	average height in meters of canopy in or adjacent to plot
5. NTAGE	age of nest tree in years
6. CANAGE	average age of canopy trees in or adjacent to plot
7. NOTREES	number of all trees > 5 cm dbh and > 2 meters tall per ha
8. DBHLT25	number of all trees 5-25 cm dbh and > 2 meters tall per ha
9. DBH2648	number of all trees 26-48 cm dbh and > 2 meters tall per ha
10. DBHGT48	number of all trees > 48 cm dbh and > 2 meters tall per ha
11. LVEVER	number of live evergreen trees on plot > 5 cm dbh and > 2 meters tall per ha
12. PERSLOP	percentage slope of plot
13. HUMHAB	distance in meters to nearest human habitation
14. WATER	distance in meters to nearest early season water (stream, river, pond, lake)
15. FOROP	distance in meters to nearest forest opening; measured to the nearest upland break in the forest continuity, such as created by a trail, field, etc.

Habitat Evaluation

Five (5) back-mounted and 9 side-mounted boxes were used. Compass orientation of entrance holes from 12 used boxes and 6 natural cavities were pooled and placed into 8 quadrants for evaluation (i.e. quadrant A = 1-45 degrees, quadrant B = 46-90 degrees, and so on). Quadrants A, B, C, D, E, F, G, and H held 5, 0, 2, 2, 2, 1, 4, and 2 nests respectively. No significant difference was found in regards to entrance hole orientation (chi-square = 2.389). Entrance holes for 4 additional nests faced skyward and thus were not included in the above evaluation.

Heights of 14 used nest boxes were compared to 22 unused boxes and 7 natural cavities using T-tests. Although heights for used boxes (\bar{x} = 6.2 m, range 4.1-10.9 m) differed little from unused boxes (\bar{x} = 6.1 m, range 4.7-7.6 m), P = 0.90, they did differ from natural cavities (\bar{x} = 8.2 m, range 6.3-11.0 m) P = 0.034.

Tree species on which used boxes were located include: red oak (*Q. rubra*) (n = 4), bur oak (*Q. macrocarpa*) (n = 1), basswood (n = 2), white elm (*U. americana*) (n = 2), red elm (*U. rubra*) (n = 1), black ash (n = 2), jack pine (n = 1), red pine (*P. resinosa*) (n = 1), and white pine (*P. strobus*) (n = 1). Natural

Table 3. Means, standard deviations, and ranges of habitat variables for 22 Barred Owl nests.

variable	\bar{x}	SD	range
HTNSTTRE	17.2	3.8	9.1-25.0
DBH	43.4	15.5	16.5-80.5
CAVHT	6.7	2.1	3.4-11.0
CANHT	17.8	3.2	12.8-25.0
NTAGE	91.7	39.1	47-200
CANAGE	65.1	15.1	36-96
NOTREES	670.5	302.2	100.0-1150.0
DBHLT25	536.4	281.9	75.0-975.0
DBH2648	119.3	60.2	0.0-250.0
DBHGT48	14.8	16.7	0.0-50.0
LVEVER	34.1	68.0	0.0-300.0
PERSLOP	6.5	5.9	0.0-20.0
HUMHAB	762.0	840.7	12.5-2667.0
WATER	122.3	189.5	0.0-612.6
FOROP	47.3	55.2	0.0-198.1

Table 4. Forest types within 100 m of 24 Barred Owl nests.

forest type	#nests	%
northern hardwoods	15*	62.5
lowland hardwoods	4**	16.7
aspen/birch	3	12.5
oak	1	4.2
jack pine	1	4.2

* includes 6 natural cavity nests

** includes 2 natural cavity nests

Table 5. Habitat characteristics within a 314 ha (1 km radius) circular plot at 24 Barred Owl nests.

habitat	\bar{x} ha	SD	range	%
forest	211.0	47.9	146.0-296.4	67.2
water	50.2	43.1	0.0-130.4	16.0
ub/ug/lg	29.5	17.2	0.0-51.6	9.4
marsh	12.5	14.0	0.0-55.6	4.0
ag	5.8	12.4	0.0-50.4	1.9
lb	3.0	7.2	0.0-28.8	0.9
road	2.0	2.2	0.0-5.6	0.6

cavity nests were located in basswood (n = 3), red elm (n = 2), white elm (n = 1), yellow birch (*B. alleghaniensis*) (n = 1), and sugar maple (*A. saccharum*) (n = 1).

The 0.04 ha and 314 ha circular plot data were taken at 22 and 24 nests, respectively (2 sites were lost to logging before the 0.04 ha plot data were taken). Table 3 lists the means, standard deviations, and ranges of the 15 variables taken at the 0.04 ha plots. The forest types that nest sites were located in are listed in Table 4. Data from the 314 ha circular plots are shown in Table 5. It is important to note that

while the 314 ha plots do not represent the actual habitat utilized by a territorial Barred Owl pair, they can offer something in the way of general habitat assessments. I did not compare used sites against unused sites because I was not able to prove that there were in fact no owls present in areas surrounding the unused sites.

BOX USE BY OTHER WILDLIFE

Detailed notes recording other species use were available on 26 boxes (Table 6), with raccoon and squirrel (3 species) activity predominating. Boxes were used as nest sites by raccoon, squirrel (3 species), wood duck, hooded merganser (*Lophodytes cucullatus*), and vespid wasps (*Hymenoptera*, subfamily *Vespinae*). During fall dispersal, squirrels often placed 25-30 cm of leaf and twig material into the boxes. It was not uncommon to find red or flying squirrels in boxes containing nests made by gray squirrels. Four dead gray squirrels and 1 dead raccoon were found in boxes during January inspections (natural mortalities). Fifty-two percent (52%) of the boxes required annual cleaning; 90% required cleaning at some time or another during the project.

Table 6. Box use by other wildlife.

species	boxes used	visits
Gray Squirrel (<i>Sciurus carolinensis</i>)	18	31
Red Squirrel (<i>Tamiasciurus hudsonicus</i>)	6	9
Northern Flying Squirrel (<i>Glaucomys sabrinus</i>)	6	10
Raccoon	14	18
Porcupine (<i>Erethizon dorsatum</i>)	2	4
Wood Duck	4	5
Hooded Merganser	2	2
Northern Flicker (<i>Colaptes auratus</i>)	1	1
Vespid Wasp	4	4

DISCUSSION

Data collected during this study reveal that Barred Owls will readily utilize artificial nest boxes, and are willing to tolerate differences in box designs, mounting styles, cavity heights, entrance hole orientation, tree species, tree diameters, tree density, and general habitat features. This should come as no surprise when we understand their need for the limited supply of suitable nest sites - at least in this study area they simply have little choice.

Nest boxes are a viable tool for researching various aspects of Barred Owl ecology. While Barred Owls may function as mature/old growth forest indicator species, the sporadic nesting that was shown in this study suggests that a population monitoring system based on the use of boxes would be inappropriate. Preferred monitoring options may include a taped call/playback response census and/or a system of monitoring the overall mature/old growth forest habitat component.

We have traditionally associated Barred Owls with large tracts of mature lowland hardwoods, such as those found along riverine systems. Nicholls (1973) found 9 radioed Barred Owls to prefer oak and mixed hardwood-conifer habitats in east-central Minnesota. Home ranges averaged 226 ha (range 85-365 ha) in size. In this study, nesting activity occurred predominately in the northern hardwood type, followed by the lowland hardwood, aspen/birch, oak, and jack pine types. Forest types averaged 65 years old and covered 211 ha (67.2%) of the 314 ha plots. The types were basically homogenous, with very few recent canopy disturbances (e.g. logging operations). While our assertion of owls associated with the lowland hardwood type is not incorrect, we perhaps have overlooked the additional habitat provided by the mature northern hardwood, oak, and mixed hardwood-conifer forest types. The owls' use of these types may be a recent condition in Minnesota however, as these maturing types may only now be providing the adequate hunting and nesting areas required by this species. Additional home range/habitat evaluation studies employing radio-telemetry are suggested.

For those interested in putting up Barred Owl boxes I recommend the following:

1. Use 2.5 cm thick untreated/unpainted wood for box material. A 30 x 30 x 50 cm box is adequate. No wire mesh "ladder" is needed inside. Eight or so drain holes should be drilled through the box bottom.
2. Covered boxes should have an entrance hole \geq 18 cm.
3. Topless boxes can be 30 x 30 x 40 cm. Rain and snow did not appear to be a problem for the owls, but access into the 50 cm deep boxes did.
4. Boxes should be placed 7-8 m above ground in a long-lived tree. Trees can be any species and any dbh, but those that provide a 30 m clear flight path to the box (few low limbs or other obstructing vegetation) are desirable.

6. Boxes should be placed in tracts of mature northern hardwoods, lowland hardwoods, or mixed hardwood-conifers (250 ha or larger) in association with water (lakes, ponds, streams, rivers) and openings (upland grass/brush and lowland grass). Some aerial photo interpretation work here will be beneficial in selecting potential box sites. Avoid areas of known Great Horned Owl (Bubo virginianus) or Red-tailed Hawk (Buteo jamaicensis) activity.
7. To minimize human, corvid, and raccoon encounters with owls, boxes should not be placed within 100 m of a house, field, lake, stream, or road edge, but rather in the forest interior.
8. Nest trees should be spiked for climbing, and wrapped with a 0.7 m wide piece of light metal sheeting (to minimize raccoon predation).
9. Boxes should be cleaned prior to the nesting season, leaving only 5-7 cm of nesting substrate in the box.

ACKNOWLEDGEMENTS

I sincerely thank Catherine M. Fouchi, Douglas C. Keran, Mark D. Nelson, Jon Carter, Tony Carter, Conrad Schmidt, Bob Bachman, Paul Bunyan Arboretum personnel, and the Mantrap Valley Conservation Club for their assistance in various portions of this project.

LITERATURE CITED

- Follen, D.G., Sr. 1982. The barreds of the big house. *Passenger Pigeon* 44(1):20,22.
- Jakes, P.J. 1980. Minnesota forest statistics, 1977. USDA Forest Service Resource Bulletin NC-53. North Central Forest Experiment Station, St. Paul, Minnesota. 85 p.
- James, F.C., and H.H. Shugart, Jr. 1970. A quantitative method of habitat description. *Audubon Field Notes* 24:727-736.
- Johnson, D.H. 1980. Barred Owls use nest box. *Loon* 52(4):193-194.
- _____ and D.G. Follen, Sr. 1984. Barred Owls and nest boxes. *Raptor Research* 18(1):34-35.
- Nicholls, T.H. 1972. Barred Owl habitat use as determined by radiotelemetry. *Journal of Wildlife Management* 36(2):213-224.
- Rubey, W.W. 1927. Barred Owls nesting in box near Washington, D.C. *Bird-Lore* 29:408-409.
- Snyder, B., and B. Drazkowski. 1981. (newsletter). *Hiawatha Valley Bird Notes* 18(7):2.

Thomas, J.W., R.J. Anderson, C. Maser,
and E.L. Bull. 1979. Snags. In:
J.W. Thomas (ed.). Wildlife habitats
in managed forests-the Blue
Mountains of Oregon and Washington.
USDA Handbook 553. 511p.

Titus, K., and J.A. Mosher. 1981. Nest-
site habitat selected by woodland
hawks in the central Appalachians.
Auk 98(2):270-281.

Distribution, Density, and Habitat Relationships of the Barred Owl in Northern New Jersey¹

Thomas Bosakowski,² Robert Spelser,³
and John Benzinger⁴

Abstract. -- Barred Owls (*Strix varia*) were surveyed in northern New Jersey during a four-year period (1983-86) using vocal imitations (85.5%), tape-recorded calls (8.0%), or non-vocal contacts (6.5%). A total of 62 different locations (territories) were found with a pair responding at 56.5% of locations. Of these locations, 34 were found in an intensive study area (468 sq km) which was systematically searched during the study period. Within this area, one tract of prime habitat (120 sq km) was systematically searched during a single breeding season (1986) and contained 17 locations (0.142 pairs/sq km). The northern half (60 sq km) of this tract contained most of the owl locations (12) and was almost complete wilderness while the southern half contained several suburban housing developments, a major 4-lane highway, and less stands composed of eastern hemlock (*Tsuga canadensis*). Barred Owl habitat was classified visually along 6 different habitat gradients at 36 locations and was compared statistically (Fisher Exact Test) to the habitat at 29 Eastern Screech-Owl (*Otus asio*) and 22 Great Horned Owl (*Bubo virginianus*) locations. Habitat analysis indicated that Barred Owls showed the most preference for mature timber stands, mixed hemlock-hardwood forest, swamps, and proximity to water sources. Barred Owls showed the least preference with regard to areas of extensive forest clearings and proximity to human habitation. Habitat management suggestions are presented based on these findings and the literature. Most critical to Barred Owl success thus far are considered the presence of large remote forest preserves with an abundance of freshwater wetlands and mature timber.

INTRODUCTION

The Barred Owl (*Strix varia*) was listed as a threatened species in New Jersey in 1974 (N.J. Dept. Environmental Protection, Non-game and Endangered Species Project) and has been selected as a management indicator species in some southern Appalachian national forests (Title 36, U.S. Code of Federal Regulations, Sec. 219.19). Given the lack of long-term population surveys of the Barred Owl, however, it is difficult to assess the true status of this owl within its wide range. Simultaneous with this study, Sutton and Sutton (1985) surveyed Barred Owls in southern New Jersey in the coastal plain physiographic province, an ecological subdivision not found in northern New Jersey. They concluded that numbers of Barred Owls were "considerably higher than published accounts intimate" and provided some anecdotal evidence that the population has been increasing in recent decades. In northern New Jersey, the distribution and ecology of the Barred Owl population is not well known, most accounts referring to small localized populations (Stearns 1947, Gutmore 1977, Kane et al. 1985). The pur-

pose of our investigation was to explain the distribution of Barred Owls in northern New Jersey by quantitatively investigating what factors favor or hinder successful inhabitation. In identifying such factors, valuable management insight for maintaining or improving the status of Barred Owls throughout their range might be realized.

STUDY AREA

Northern New Jersey was selected as the study region; it contains three of the four physiographic provinces of New Jersey (Fig. 1). The Piedmont is a relatively flat, low elevation zone of clay and sandstone composition. This region is the most heavily urbanized region in northern New Jersey; some rural areas and parks occur toward its southern end. Forest growth is primarily oak (*Quercus* spp.) and other hardwoods. This region is abutted to the west by the Highlands, a belt of granitic rolling hills with an average elevation of about 300 m. This region is sparsely populated with small villages and towns, but in general, it is heavily forested. While oak predominates much of the region (Beull 1966, Russell 1981), eastern hemlock (*Tsuga canadensis*) and the northern hardwoods Birch-Beech-Maple (*Betula alleghaniensis* - *Fagus grandifolia* - *Acer saccharum*) thrive along ravines, water courses, and plateaus where richer, deeper soils and moisture have accumulated. The Kittatinny Valley extends along the western base of the Highlands and is an area of extensive agriculture, dotted with small rural villages.

¹Paper presented at the symposium, Biology and Conservation of Northern Forest Owls, Feb. 3-7, 1987, Winnipeg, Manitoba. USDA Forest Service General Technical Report RM-142.

²Thomas Bosakowski is a Zoology doctoral student at Rutgers University, Newark, N.J. and Associate Scientist of Toxicology and Pathology, Roche Research Center, Nutley, N.J.

Few tracts of undisturbed forest remain here. The conglomeritic Kittatinny Ridge, however, with an average elevation of about 400 m, is steep and almost entirely forested. Tree composition is mostly oak-pine (*Pinus* spp.) with various associations of northern hardwoods and occasional hemlocks.

Within the study region, an intensive study area (468 sq km) was designated such that it was possible to search virtually the entire area for owl territories during the four-year period, 1983-1986. Within the intensive study area, one area of forest (120 sq km) at the Pequannock Watershed was systematically searched during the 1986 breeding season to determine owl densities since this area represents prime Barred Owl habitat. The northern half of this area is virtually complete wilderness; the southern half was slightly to moderately encroached upon by a few small suburban developments and a major four-lane highway (Route 23), thus providing a good comparison on the effects of land development on Barred Owl density.

METHODS

We began recording Barred Owl locations in the spring of 1983 during a survey of Northern Goshawk (*Accipiter gentilis*) populations in the Highlands (Speiser and Bosakowski 1984). From March-June in 1984, 1985, and 1986 additional Barred Owls were located throughout the study region and the intensive study area. During surveys, either imitated calls (typical eight-note hooting series) or cassette taperecorder broadcasts (Sony CFM-15) were employed for about a 5-min duration or until a response was obtained. If no response occurred within an additional 5-min period, the survey was continued elsewhere. Gould (1977) and Forsman et al. (1984) surveyed populations of Spotted Owls (*Strix occidentalis*) in California and Oregon, respectively, using a combination of vocal imitations and tape-recorded broadcasts. Likewise, Sutton and Sutton (1985) also used both methods to survey Barred Owls in southern New Jersey. Although some other investigators of the Barred Owl have relied completely on the use of cassette tape playback (Gutmore 1978, Smith 1978, Elody 1983, McGarigal and Fraser 1984, 1985), all have used different equipment, recordings, and sound wattage such that no standardized system has yet been established. Regardless of the method used, most authorities agree that the response of the owl indicates that its breeding territory has been intruded upon (reviewed by Fuller and Mosher 1981) and in the Spotted Owl, at least, only adults that are paired are believed to respond vigorously to calls (Forsman et al. 1977). During the breeding season, this technique has a very good success rate (Table 1) and therefore we consider the possibility of overlooking a breeding territory to be minimal. Since Stearns (1947) and Smith (1978) believed that Barred Owl hooting was audible up to 0.4-0.5 miles, then sampling points can theoretically be spaced as far as one mile (1.6 km) apart to attain systematic coverage of an area as long as calls are given in a radial pattern from the calling source. When owls were found in close proximity (1-2 km) we often were able to verify them as separate pairs/individuals by simultaneous or near simultaneous vocalizations (Forsman et al. 1977, 1984), by obvious natural boundaries (Smith 1978) or by unnatural boundaries such as developments and highways. Furthermore, over half of the owl locations reported here were reconfirmed from one to seven times during the course of the study.

Surveys of other woodland owls were also conducted to serve as a control comparison for analyzing habitat information. Essentially, there are only two other owl species which are common breeders of woodland habitat in northern New Jersey, i.e., the Great Horned Owl (*Bubo virginianus*) and the Eastern Screech-Owl (*Otus asio*). A similar method was used to detect these species, except that Screech-Owl detection was almost completely limited to night surveys (94%) while Great Horned Owls were more often detected during the day

(63%) as were Barred Owls (55%). Although there was some variability in location methods, the sample size for each species was large (22 - 36 different territories), and vast areas of habitat were sampled during the four-year study period. Due to the multi-dimensional habitat parameters involved, it was impossible to quantify search effort spent in all the various habitat types encountered; however, we deliberately tried to avoid search bias for each species such that relative comparisons among all species were meaningful.

Table 1. -- Response rate of Barred Owls to imitated or taped calls at some known traditional breeding locations with span of years of first and last known response given in parentheses. Note that these data represent the minimal response rates since a non-response may have been due to the death or permanent relocation of the owl(s).

Location	Breeding Season		Non-Breeding Season	
	no. of re-checks	no. of responses	no. of re-checks	no. of responses
<i>Wanaque FWMA</i>				
<i>Jennings Creek (1980-1985)</i>	2	2	1	0
<i>unnamed creek (1983-1985)</i>	1	1	-	-
<i>Beech Creek (1980-1984)</i>	4	4	2	2
<i>Hewitt Brook (1984-1986)</i>	4	3	2	0
<i>Norvin Green SF (1984)</i>	1	1	3	0
<i>Pequannock Watershed</i>				
<i>Cedar Pond (1983-1986)</i>	5	5	2	0
<i>Dunkers Pond (1986)</i>	1	0	-	-
<i>Henderson Road (1986)</i>	2	2	-	-
<i>Henderson Road North (1986)</i>	2	1	-	-
<i>Lake Stockholm (1986)</i>	1	1	-	-
<i>Timber Creek (1986)</i>	2	1	-	-
<i>Tenaco Pipeline (1985-1986)</i>	1	1	-	-
<i>Hanks Pond (1986)</i>	-	-	1	1
<i>Sterling Forest (New York)</i>				
<i>Sterling Lake (1978-1985)</i>	2	1	4	1
<i>Cedar Pond (1978-1985)</i>	-	-	3	2
<i>High Point State Park</i>				
<i>Sawmill Lake (1983-1986)</i>	1	1	-	-
<i>Parker Brook (1986)</i>	1	1	-	-
<i>Great Swamp NWR (1979-1985)</i>				
<i>New Vernon Road</i>	1	1	-	-
<i>Woodland Road</i>	1	1	-	-
<i>Meyersville Road</i>	1	1	-	-
<i>White Bridge Road</i>	1	0	-	-
Totals	34	28	18	6
Response Rate	82.4%		33.3% *	

abbreviations: FWMA = fish and wildlife management area, SF = state forest, NWR = national wildlife refuge. * = significantly different than response during breeding season (Fisher Exact Test, $p = 0.0007$).

Table 2. -- Habitat classification system for northern New Jersey owl sightings. For each owl location, one selection was made from each category which best described the habitat within a 100 m radius of the point where the owl(s) was first detected. If more than one choice was applicable, then the two most prevalent types were selected, each given a value of (0.5).

SUCCESSIONAL STAGE:

1. young field - low herbaceous plant cover only.
2. old field - mixed herbaceous cover with up to 50% shrub cover.
3. shrubland - low thickly-growing woody-stemmed plants (shrubs) covering over 50% of area.
4. young forest - saplings and poles mostly less than 15 cm in DBH.
5. submature forest - moderate-aged stands mostly between 15-30 cm in DBH.
6. mature forest - oldest stands mostly over 30 cm in DBH (including old-growth).

DOMINANT TIMBER TYPE:

1. Oak-Hardwood - (*Quercus* spp., *Carya* spp., *Fraxinus americana*, *Acer rubrum*, *Betula lenta*, *Tilia americana*, *Liriodendron tulipera*, *Prunus serotina*, *Nyssa sylvatica*).
2. Northern Hardwood - (*Acer saccharum*, *Betula alleghaniensis*, *Fagus grandifolia*)
3. Hemlock - (*Tsuga canadensis*)
4. Pine - (*Pinus strobus*, *P. resinosa*, *P. sylvestris*, *P. rigida*)
5. Spruce - (*Picea abies*)
6. Cedar - (*Chamaecyparis thyoides*, *Thuja occidentalis*, *Juniperus virginiana*)

TOPOGRAPHICAL TYPE:

1. lakeshore - terrestrial community found on the edge of open bodies of water.
2. marsh - inundated land with emergent herbaceous plants.
3. swamp - permanently flooded timber stands, frequently containing dead wood.
4. riverine - floodplain forest, alluvial basins, valleys, gorges.
5. upland - well-drained plateaus, ridges, upper slopes.

CLEARINGS (percent estimate, select only one)

1. none
2. trail/road represents only clearing
3. <10%
4. 10-50%
5. 50-100%

DISTANCE TO WATER SOURCE and HUMAN HABITATION

(select one choice for each of these two categories)

1. 0-100 m
2. 100-500 m
3. >500 m

DBH = diameter at breast height.

All owl locations were plotted on detailed local or regional maps and the habitat was classified according to the categories defined in Table 2. In most cases, habitat classification was achieved with visual estimates in the field; actual measurement was needed only for a few borderline cases. All habitat classifications were made by the first author to avoid interobserver variability (Lehner 1979). Only one habitat profile was made per owl territory; 26 Barred Owl territories were not quantified. The Fisher Exact Test was used to test for differences in proportions (Zar 1974) between the Barred Owl sample population and the two control species (Great Horned Owl and Screech-Owl). Barred Owl locations were

transferred to a section of a road map (Travel Vision Map, General Drafting Co., Convent Station, N.J.) to provide a general distribution map. Pellets found at a Barred Owl winter roost site were examined quantitatively by counting the number of skulls and mandibles (divided by 2) as described in Marti (1974).

RESULTS

Censusing

A total of 62 Barred Owl locations (territories) was recorded during the study period 1983-1986 (Fig. 1): 53 with imitated calls, 5 with cassette tape broadcasts, 2 calling on own, and 2 visual sightings. Barred Owl locations were intentionally found during the breeding season (58) with only five locations found during non-breeding months. At 35 locations (56.5%), the owl was joined by its mate (total = 97 owls), although at a few single locations a pair was known to be present before the study period. Apparently, both owls will not always respond vocally, especially since the female might be incubating or brooding young and may be reluctant to call (Devereux and Mosher 1982). Furthermore, we noted that it frequently required a longer period of continued owl broadcasts (5 to 15 min) to prompt the second owl (presumably the female) into calling. Since our broadcasts were generally of shorter duration, this may also help explain why more than one-third of the owls did not show evidence of being paired adults. Similarly, Smith (1978) found pair response at 64% of Barred Owl locations in New England. In the Spotted Owl, Gould (1977) found pair response at only 34.5% of locations. Barred Owl response to calls was greatest during the breeding season (Table 1) and showed no obvious dependence on time (am or pm) or cloud cover. In addition, we also found that pair responses were more frequent during the breeding season (Table 3) and none occurred during winter.

Table 3. -- Seasonal variation in the frequency of paired and single Barred Owl responses (data includes repeated trials at some locations).

	single	pair
Jan	3	0
Feb	1	1
Mar	10	12
Apr	16	16
May	21	9
Jun	11	11
Jul	4	2
Aug	0	1
Sep	2	0
Oct	2	1
Nov	1	0
Dec	4	0

Territorial Behavior

In most cases, Barred Owls responded vocally well before they arrived to our calling site, but occasionally they flew-in silently to investigate us. Even though we usually wore inconspicuous clothing and tried to hide in available brush, most owls were shy and would generally remain well hidden while calling. If they caught a glimpse of us, they would usually flush and become silent or call from a safer distance. Only on six occasions did they

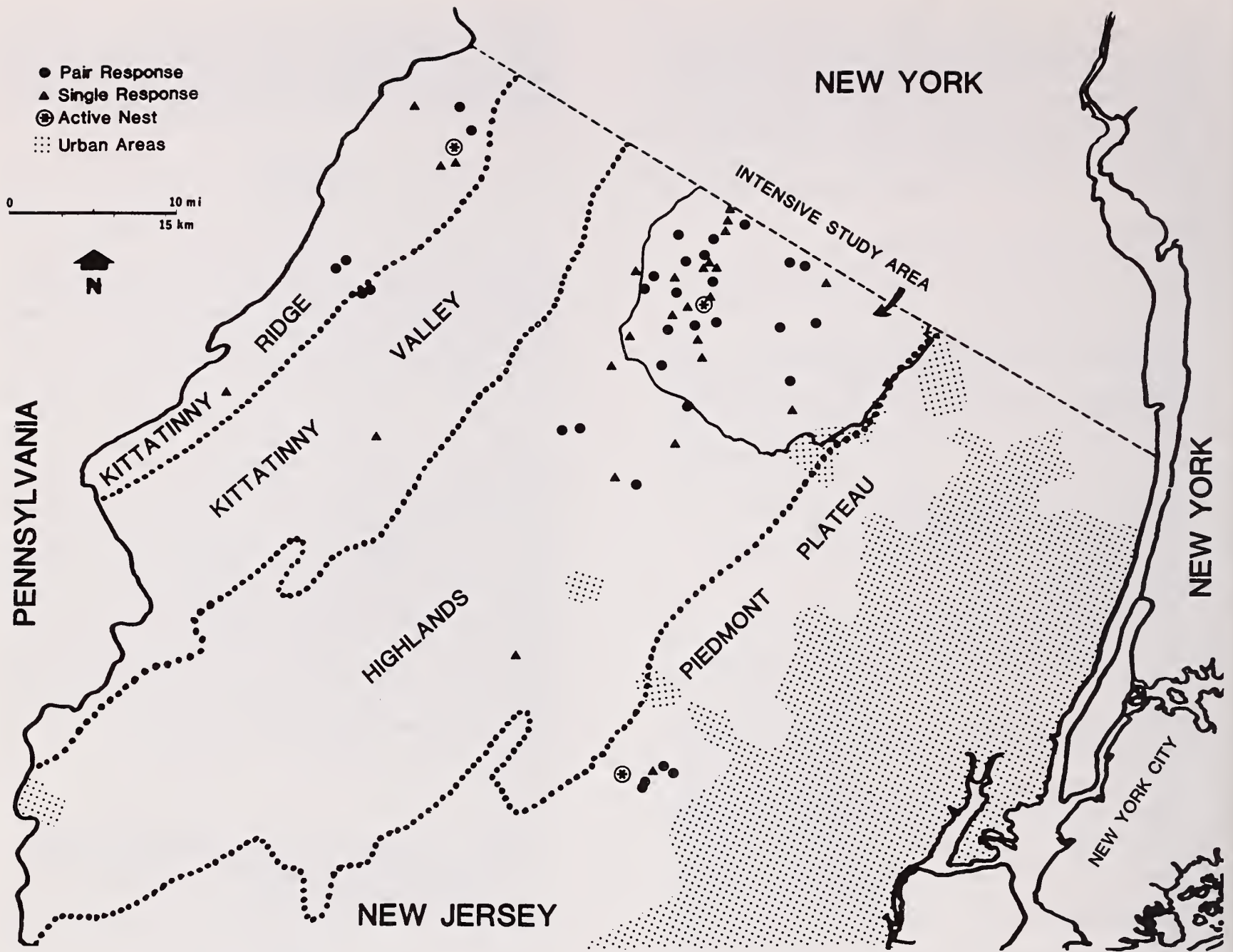

Figure 1. -- Map of northern New Jersey showing major physiographic subdivisions and distribution of Barred Owls from 1983-1986. Intensive study area was systematically searched during this period.

continue calling and almost completely ignore our presence even when we were in direct view. When a pair was present, they frequently perched close-by (often in the same tree) and began an extremely loud chorus of howls, hoots, shrieks, and tremulous wailings, often in rapid succession. On one occasion, two of us were well hidden while calling and decided to challenge a pair of chorusing owls with our own vocal imitation. This caused the owls to stop vocalizing momentarily, but in less than one minute, they began again. The owls sounded as if they were agitated by our response and continued to respond alternately to our challenge, frequently cutting us off before we had finished a complete chorus (15-20 sec). This vocal battle lasted nearly 15 minutes until one of the owls moved closer and saw us. These observations suggested to us that the owls were completely fooled by our imitated calls, and as such, protested strongly against intrusion by what they presumed to be conspecifics.

Density

In the intensive study area, 34 locations were found during the period (0.073 pairs/sq km), many of which were known to be traditional sites (see Table 1). We believe this figure to be very close to the total breeding population of the area since virtually all suitable woodlands were carefully censused during the four-year period. Unsuitable areas that were not checked were places such as high density suburban zones, industrial and commercial areas, and other high human-use areas such as ball fields, camps, bathing beaches, marinas. Barred Owls are considered non-migratory permanent residents by most authorities (Bent 1938, Bull 1964) and presumably retain the same area as a territory for many years (see dates in Table 1). In support of our observations, Bent (1938) reported that several Barred Owl territories remained occupied for over 30 years. Similarly, Forsman et al. (1984) believed that the Spotted Owl occupies its territory for life and noted 5 cases where marked individuals that disappeared were replaced the following spring. Therefore, we do not believe that the four-year study period produced an inaccurate estimate of the total owl population in

the intensive study area due to frequent relocation of existing pairs. Most of the Barred Owl territories were distributed in the western half of the intensive study area (Fig. 1) which was much less developed.

In the Pequannock Watershed study area, a total of 17 locations was found during the 1986 breeding season (Fig. 2): at 8 locations a pair responded (47%), at 7 sites a single resident responded on at least two different occasions (female may have been incubating or brooding young), and at 2 sites only a single response was obtained (sites not rechecked - may well be residents). Assuming that all locations represented paired adults (see rationale in methods section), then the density of the 120 sq km area was 0.142 pairs/sq km and the mean nearest-neighbor distance was 1.96 km (CV = 49.5%).

Distribution

Barred Owls occurred in all four major physiographic regions of northern New Jersey (Fig. 1). Although southern areas were less intensively searched, regional reports (Hanisek 1984, Kane and Valent 1986) verify that few Barred Owls inhabit the southern Piedmont, southern Highlands, and Kittatinny Valley. In the Piedmont, the small but dense population are traditional residents of the Great Swamp National Wildlife Refuge (2800 ha) vicinity and few are known to exist elsewhere in this region due to heavy urbanization and development impacts. The Highlands population, the largest, is not just the result of more intense search effort, but also reflects the presence of many large forest preserves in the northern end: Pequannock Watershed (14000 ha) with adjacent Wawayanda State Park (4200 ha), Wanaque Fish and Wildlife Management Area, Sterling Forest (private), Mahlin Dickerson County Reservation (520 ha), Norvin Green State Forest, and Piccatinny Arsenal (U.S. Army). At the southern end, the Highlands is mostly privately owned with increasing amounts of farmland, second-growth stands, and much greater fragmentation of woodlands. In the adjacent Kittatinny Valley, this trend is true throughout its entire extent with even more intense agriculture and virtually no forest preserves, hence, explaining the low number of Barred Owl locations. The Kittatinny Ridge, the smallest region, is mostly state and federal land and nearly all the land is forested. Accordingly, Barred Owl abundance was relatively good (9 locations) considering the small size of this region. The fewer number of owls near the southern end of this region was considered the result of the increasing steepness of the ridge which resulted in fewer wetlands and stunted xeric oak forests.

Habitat Analysis

Most Barred Owls were located in mature timber stands, as opposed to Screech-Owls, found more often in other successional stages, and Great Horned Owls, found more in young field habitat (Fig. 3a). Barred Owls were encountered less often in oak-hardwood stands than Screech-Owls and Great Horned Owls, and were more often in hemlocks (Fig. 3b). Barred Owls were more often found in northern hardwoods than Screech-Owls but not significantly different from Great Horned Owls. The relative amount of clearings within the stands showed that Barred Owls were found more frequently in areas with no clearings or trail only when compared to the other woodland owls (Fig. 3c). Conversely, Barred Owls were observed significantly less in areas with greater than 10% clearings. The most significant topographical difference was that of Barred Owl abundance in swamps (Fig. 3d) when compared to Screech-Owls or Great Horned Owls. In upland habitat, Barred Owls were found significantly less often than Great Horned Owls. Barred Owls were found significantly closer to water sources than Great Horned Owls (Fig. 3e) and only slightly closer than Screech-Owls (not significant). Barred Owls were less often within 100 m of human habitation (Fig. 3f) when compared to Screech-Owls and Great Horned Owls and favored sites that were greater than 500 m when compared to these owls. Screech-Owls showed the reverse trend - actually favoring woodlands with nearby human habitation. Great Horned Owls showed neither an avoidance nor preference with regard to their proximity to human habitation.

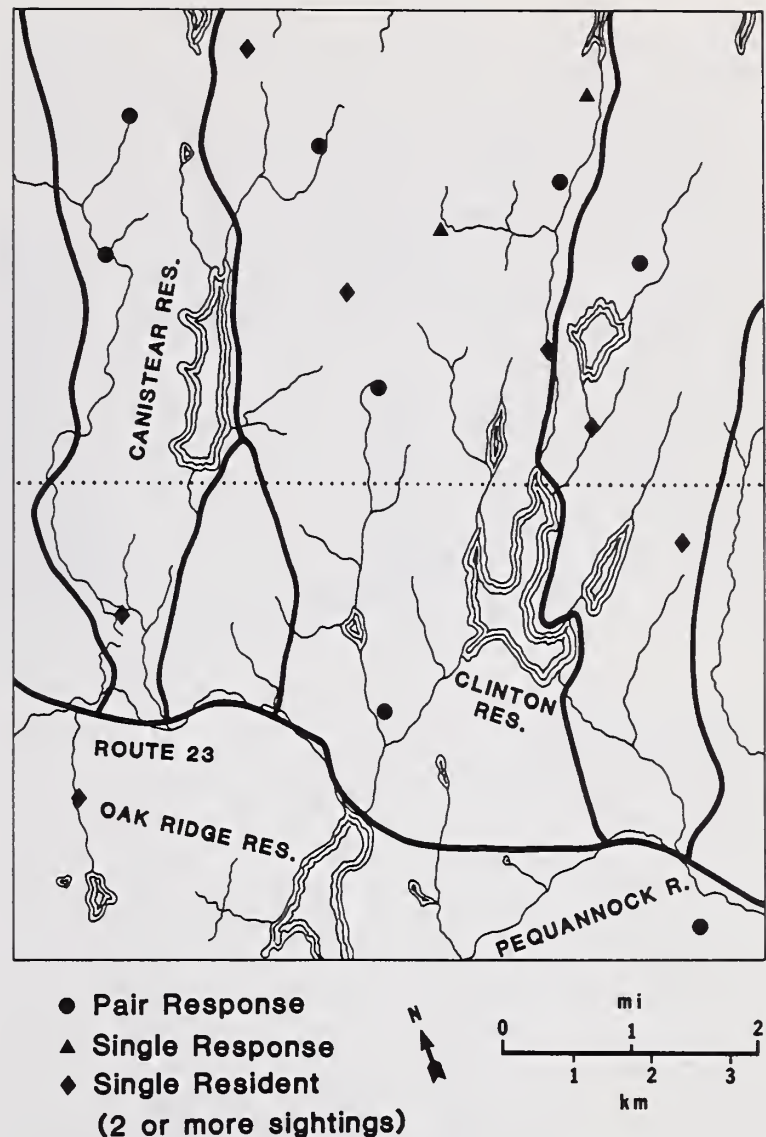

Figure 2. -- Distribution of Barred Owls in the 120 sq km Pequannock Watershed study area during 1986 breeding season. Although the area was systematically searched, note that the density of owls (12 territories) was much greater in the northern half of the area which was almost complete wilderness (above dotted line). In contrast, the southern half contained a major highway (Route 23), several suburban housing developments, and less stands containing eastern hemlocks, and only 5 territories were established. Average nearest-neighbor distance for the northern half was 1.48 km (CV = 17.6%) and 3.09 km (CV = 35.3%) for the southern half.

Table 4. -- Analysis of 34 Barred Owl pellets from winter roost at the Great Swamp National Wildlife Refuge, Meyersville, 1985-86.

Mammals	number
Short-tailed Shrew (<i>Blarina brevicauda</i>)	5
Star-nosed Mole (<i>Condylura cristata</i>)	1
Meadow Vole (<i>Microtus pennsylvanicus</i>)	18
White-footed Mouse (<i>Peromyscus leucopus</i>)	2
Southern Flying Squirrel (<i>Glaucomys volans</i>)	1
Birds	
Blue Jay (<i>Cyanocitta cristata</i>)	2
Invertebrates	
Crayfish (<i>Cambarus sp.</i>)	2
Total Prey Items	31
Prey Items/Pellet	0.91

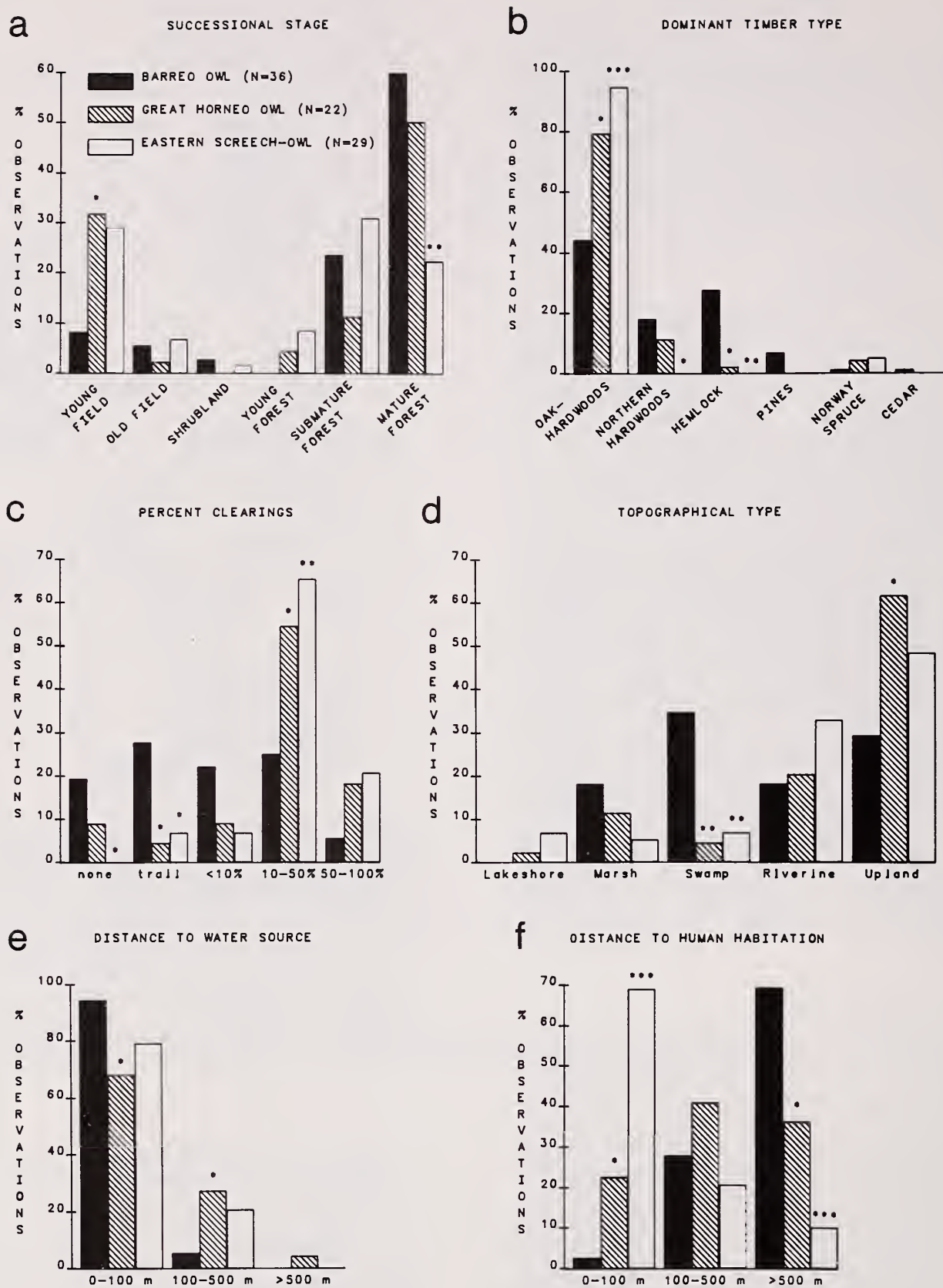

Figure 3. -- Habitat comparison of Barred Owl to two other sympatric woodland owl species in northern New Jersey. See Table 2 for description of habitat variables. Asterisks indicate a statistically significant difference from Barred Owl population (Fisher Exact Test. *** $p < .001$, ** $p < .01$, * $p < .05$).

Nest Trees

Only three Barred Owl nests were found during the study. All were in large holes of large dead trees and included white oak (*Quercus alba*), sugar maple (*Acer saccharum*) and black willow (*Salix nigra*). Despite careful checking of all large stick nests found during this and other raptor studies (Speiser and Bosakowski 1984, 1987) we have never observed these nests to be used by Barred Owls as has been reported elsewhere (Bent 1938). Apparently, cavity availability is adequate in the woodlands presently occupied by Barred Owls in northern New Jersey.

Food Habits

Thirty-one food items were identified from pellets collected at a Barred Owl winter roost (Table 4). The roost was situated in a Norway spruce (*Picea abies*) grove that bordered extensive old fields and open marsh, hence explaining the abundance of meadow voles taken. Unfortunately, not enough pellets were found at nest sites or other habitats to make a valid comparison among different habitat types. However, our data are in close agreement with some other food habits studies (Wilson 1938, Rusling 1951, Marks et al. 1984) which indicate that the Barred Owl might occasionally be a "specialist" on *Microtus*.

DISCUSSION

A total of 97 Barred Owls was detected on 62 territories during the study period 1983-1986. Only 5 of these locations were found during non-breeding months, but because the Barred Owl is a permanent resident, it is likely that these owls were defending permanent home ranges as indicated by other known breeding localities that were "defended" during winter (Elody 1983, this study - Table 1). When a pair responded (56.5% of locations), they usually began calling alternately with the typical eight-note hooting series which was almost always followed by a loud and frenzied chorus. Although other authors have noted this duetting (Bent 1938, Fitzpatrick 1975, Smith 1978, Devereux and Mosher 1982, Elody 1983, McGarigal and Fraser 1985), usually referred to it as "caterwauling", its purpose is poorly understood, save for the fact that it reveals the location and emotional level of the owls (Elody 1983). Of interest, we noted that this chorus was only elicited when the owls were in very close proximity to each other. Likewise, Devereux and Mosher (1982) once observed caterwauling just prior to a food exchange near a nest. Perhaps this behavior functions in mate recognition, strengthening the pair-bond and warning intruders that a pair-bond has already been established. Because these choruses were very loud and frequently given in response to our calling, this behavior seems to also have a strong territorial function, possibly supplemental to the typical 8-note call. Outside of the breeding season, the response rate of Barred Owls to calls decreases dramatically (Smith 1978, Elody 1983, this study), thus making winter census results, such as the Christmas Bird Counts, unreliable. We also found only single responses during the winter months with pairs responding primarily during the breeding season (March to June).

The intensive study area yielded 34 Barred Owl locations (0.073 pairs/sq km) during 1983-1986. The Pequannock Watershed study area, located in one of the more remote sections of the intensive study area, was occupied at 17 locations in 1986 (0.142 pairs/sq km). The latter density is comparable to Smith's (1978) data from two selected study areas (7320 ha) in New England from which we calculated densities of 0.147 (New Hampshire) and 0.191 (Connecticut). In northern Michigan, a wilderness area (9308 ha) with prime habitat (climax hemlock-northern hardwoods) was censused and found to contain a density of 0.355 (Elody 1983). If we consider the density of owls in the northern half of Figure 2 (60 sq km), where there is no highway, almost total wilderness, and more stands containing hemlock, then our owl density figures increase from 0.142 to .200, 56% of the saturation level in Elody's (1983) study area.

Most Barred Owls were observed in mature timber stands, whereas the majority of Screech-Owls inhabited younger successional stages. Great Horned Owls were found only slightly less in mature forests than Barred Owl, but were much more often associated with young fields. In Virginia, McGarigal and Fraser (1984) found that 25 Barred Owls more frequently preferred old stands (>80 yrs old) rather than young stands (<80 yrs old). In the central Appalachians, Devereux and Mosher (1984) found that Barred Owl nests (N=8) were in more mature forests than 76 random sites. Similarly, Forsman et al. (1977, 1984) found higher densities of Spotted Owls (the western congener of the Barred Owl) in old-growth forests versus young forests. In southern New Jersey, Sutton and Sutton (1985) also noted a strong association of Barred Owls with "the oldest growth and uncut stands ... of hardwood forest" although no quantitative tree data was obtained. The requirement of Barred Owls for mature woods reflects their need for large dead trees with nesting cavities (Devereux and Mosher 1984). It is also hypothesized that these forests provide clear unobstructed flight paths (little or no understory) for hunting and better prey vulnerability (Nicholls and Warner 1972, Elody 1983, Devereux and Mosher 1984).

Barred Owls have been noted to prefer mixed woods in northern latitudes (Wilson 1938, Smith 1978, Tyler and Phillips 1978, Elody 1983). This preference concurs with our findings in that Barred Owls were found in hemlock stands more frequently than the other two woodland owls. Elody (1983) concluded that coniferous growth was important to Barred Owls because it provides dense forest cover to prevent mobbing by birds and may also provide an escape medium (Carter 1925, Stirling 1970). However, this rationale does not explain why coniferous growth was not used as much by the other two owl species in our study. D.G. Smith and Gilbert (1984) noted that Screech-Owl use of evergreen cover occurred mainly during winter months which supports our observations. The distribution of mixed forest is limited mainly to the northern Highlands and sections of the Kittatinny Ridge, however, conifers are apparently not an essential requirement since more than half of the Barred Owls were found in deciduous stands (e.g., the Great Swamp maintains a dense population of Barred Owls and only a few cedars and planted conifers are available.)

In this study, Barred Owls tended to avoid areas with extensive clearings as compared to Screech and Great Horned Owls. Nicholls and Warner (1972) showed evidence that fields and open marsh habitat were avoided. Fuller's (1979) data from the same study area (radiotelemetry location every min, instead of every 15 min) showed a greater individual use of fields (5-33.3%). Devereux and Mosher (1984) found eight nests to be significantly closer to edge than random sites. Most of the Barred Owls we encountered were in deep forests with fewer and smaller clearings than Great Horned Owl or Screech-Owl territories. Our findings corroborate those of Elody (1983) who has reported the highest known breeding density of Barred Owls. He noted that forest cover was mostly contiguous with very few openings.

The major topographical difference that we found for the Barred Owl in comparison to the other owls was the preference for swamps (and other associated wetlands). Most of the literature supports this association with wet areas (Carter 1925, Errington and McDonald 1937, Bent 1938, Stearns 1947, Applegate 1975, Soucy 1976, Elody 1983, Sutton and Sutton 1985). Fuller (1979) found dense lowland habitats were used more frequently during reduced activity periods, and both marshes and swamps were used if available. Elody (1983) found a positive correlation with marsh use of seven radio-tagged owls. In southern New Jersey, Sutton and Sutton (1985) independently came to the same conclusion as we did that Barred Owls preferred freshwater wetland forest habitat over dry woodlands. Besides being avoided by human intrusion, we contend that swamps and marshes were almost always associated with a greater abundance and diversity of prey species (birds, small mammals, amphibians, crayfish, fish) than other topographical types in our region.

As expected on the basis of preference for wetlands, the Barred Owl was found closest to water sources, significantly closer than Great Horned Owl, but not Screech-Owl. The latter result is not unexpected since Ellison (1980) found a significant positive correlation between running water and Screech-Owl habitat use in Massachusetts. Apparently, water is also an important habitat component for Barred Owls as well. Karalus and Eckert (1974), Bolles (1890), and others have noted that water sources are frequently used for drinking and bathing, and the inclusion of crayfish, fish, and amphibians in the diet (Errington 1932, Rusling 1951, Korschgen and Stuart 1972, D.G. Smith et al. 1983, Devereux and Mosher 1984, this study - Table 4) indicate the use of water as a hunting habitat as well. Of interest, Gould (1974) reported that 90% of Spotted Owls were found within 0.2 miles of water and Forsman et al. (1984) found 85% of Spotted Owl nests within 250 m of water.

The Barred Owl was found to be the most sensitive of the three owl species regarding proximity to human habitation (and hence, disturbance). This result agrees with Smith (1978) who found a negative correlation of Barred Owl occurrence with human dwellings in Connecticut and New Hampshire. In southern New Jersey, Sutton and Sutton (1985) also noted qualitatively that Barred Owls were "located as far from human habitation as possible". On the other hand, our finding of Screech-Owl preference for proximity to human habitation concurs with the finding of D.G. Smith and Gilbert (1984) that Screech-Owls significantly over-utilized suburban lawns as a habitat type. Below we have submitted several explanations which should help explain this phenomenon: (1) Screech-Owls can avoid predation from Barred Owls (Errington 1932, Bent 1938, Rusling 1951) by inhabiting woodlands on the edge of suburban neighborhoods, (2) the lack of Barred Owl (and other raptors) in these areas decreases potential competition for food sources (note large overlap in prey use of Screech-Owl in Rusling 1951 and Barred Owl in this study - Table 4), (3) trimmed lawns provide excellent prey vulnerability for the owls (easy capture, lack of cover, loss of concealment by prey), (4) Human activities and structures tend to proliferate certain prey species (lawns - moles, lights - moths, garbage - rodents). In contrast, the Barred Owls' success in northern New Jersey results largely from the existence of large remote forest preserves, especially those lands that have minimal signs of human impact. Hence, we consider true wilderness areas as an essential requirement for the maintenance of healthy Barred Owl populations.

MANAGEMENT IMPLICATIONS

The optimal habitat profile for the Barred Owl is: large contiguous forests of mature and old-growth timber, mixed with hemlock, interspersed with a variety of wetland types and free of human dwellings, roads, or other unnatural disruption. We recommend that such areas be acquired as public properties and set aside as wilderness with no human manipulation of habitat. Existing public lands possessing these characteristics should not be subjected to any kind of thinning, selective or clearcutting. One of the primary arguments against logging these areas is that the creation of cleared areas will favor the invasion of the larger, more aggressive Great Horned Owl, which has been known to prey upon the Barred Owl (Bent 1938) and certainly compete for food and nesting sites. Similarly, McGarigal and Fraser (1984) noted that the Great Horned Owl will benefit if old stands are adjacent to farmland. Selective cutting of optimum habitat is also not advisable since these areas are needed as population reserves for continued replenishment of marginal habitats.

At young and submature stands, we suggest careful thinning procedures should be used for accelerating the growth of larger trees and providing the flyway space below the canopy needed by Barred Owls. Such sites, if large enough in area (at least 400 ha/pair), could become potential breeding habitat within a few decades,

especially if situated near wetlands. Dry mountain ridgetops and upper slopes are not of any apparent value to Barred Owls and these should be considered if timber harvesting or development is desired. Unfortunately, this type of terrain is seldom desirable for construction as humans usually prefer valleys and flatlands similar to areas that would be suitable for the Barred Owl. Hence, future land development remains the biggest threat to this species since our findings clearly indicate that human habitation drastically reduces habitat suitability.

Similar to our findings, Smith (1978) noted that Barred Owls always avoided suburban developments even when the canopy was virtually uninterrupted. She suggested that multifamily dwellings be considered in place of even-spaced suburban neighborhoods which waste much more valuable space. For future development, careful assessment of alternative construction sites should be encouraged to prevent further encroachment on (or fragmentation of) our valuable wilderness areas.

ACKNOWLEDGEMENTS

The authors wish to thank the following persons who generously contributed field reports or other useful information: Greg Hanisek, Joe Broschart, Walt and Nancy Lilly, Walter Lehnes (in memory of), Jim Zamos, Tom Jasikoff, Pete Bacinski, John Baranowski, Dennis Miranda, Richard Kane, and Stiles Thomas. Special thanks are also due to Gordon I. Gould, Jr. for helpful discussions, Dwight G. Smith for generously providing many useful references and encouragement, and Dee Dee Williamson for drawing the Pequannock Watershed map. We also thank Jeffrey S. Marks and Douglas W. Morrison for comments which improved the manuscript. This research was supported, in part, by a grant from the New Jersey Audubon Society.

LITERATURE CITED

- Applegate, R.D. 1975. Co-roosting of Barred Owls and Common Grackles. *Bird-Banding* 46:169-170.
- Bent, A.C. 1938. Life histories of North American birds of prey. Part 2, U.S. National Museum Bulletin 170.
- Bolles, F. 1890. Barred Owls in captivity. *Auk* 7:101-114.
- Buell, M.F., A. Langform, D. Davidson, and L. Ohmann. 1966. The upland forest continuum in northern New Jersey. *Ecology* 47:416-432.
- Bull, J. 1964. *Birds of the New York Area*. Dover Publications, New York.
- Carter, J.D. 1925. Behavior of the Barred Owl. *Auk* 42:443-444.
- Devereux, J.G. and J.A. Mosher. 1982. Nesting habits of the Barred Owl in western Maryland. *Maryland Birdlife* 38:124-126.
- Devereux, J.G. and J.A. Mosher. 1984. Breeding ecology of Barred Owls in the central Appalachians. *Raptor Research* 18:49-52.
- Ellison, P.T. 1980. Habitat use by resident Screech Owls (*Otus asio*). M.S. Thesis, University of Massachusetts.
- Elody, B.I. 1983. Techniques for capturing, marking, monitoring and habitat analysis for the Barred Owl in the Upper Peninsula of Michigan. M.S. Thesis, Michigan Tech. University.
- Errington, P.L. 1932. Food habits of southern Wisconsin raptors. Part I. Owls. *Condor* 34:176-186.

- Errington, P.L. and M. McDonald. 1937. Conclusion as to the food habits of the Barred Owl in Iowa. *Iowa Bird Life* 7:47-49.
- Fitzpatrick, J.W. 1975. A record of allopreening in the Barred Owl. *Auk* 92:598-599.
- Forsman, E.D., E.C. Meslow, and M.J. Strub. 1977. Spotted Owl abundance in young versus old-growth forests. *Oregon Wildlife Society Bulletin* 5:43-47.
- Forsman, E.D., E.C. Meslow, and H.M. Wight. 1984. Distribution and biology of the Spotted Owl in Oregon. *Wildlife Monographs* 87:1-64.
- Fuller, M.R. 1979. Spatiotemporal ecology of four sympatric raptor species. Ph.D. Thesis. University of Minnesota.
- Fuller, M.R. and J.A. Mosher. 1981. Methods of detecting and counting raptors: A Review. *Studies in Avian Biology* 6:235-246. In: *Estimating Numbers of Terrestrial Birds* (eds. C.J. Ralph and J.M. Scott), Cooper Ornithological Society.
- Gould, G.I., Jr. 1974. The status of the Spotted Owl in California. unpubl. report. California Dept. of Fish and Game. Wildlife Management Branch Administrative Report 74-6.
- Gould, G.I., Jr. 1977. Distribution of the Spotted Owl in California. *Western Birds* 8:131-146.
- Gutmore, D. 1977. Barred Owl survey in the Pequannock Watershed. *N.J. Audubon* 3:184-185.
- Hanisek, G. 1984. Summer Field Notes (Region No. 1). *Records of New Jersey Birds* 10:80.
- Kane, R., W.J. Boyle, Jr., and A.R. Keith. 1985. Breeding birds of Great Swamp. *Records New Jersey Birds* 11:29-33.
- Kane, R., and M. Valent. 1986. 1986 North Jersey Barred Owl survey. *Records of New Jersey Birds* 12:69-70.
- Karalus, K.E. and A.W. Eckert. 1974. *The owls of North America*. Doubleday and Company, Inc., Garden City, NY. 280 pp.
- Korschgen, L.J. and H.B. Stuart. 1972. Twenty years of avian predator-small mammal relationships in Missouri. *Journal of Wildlife Management* 36:269-282.
- Lehner, P.N. 1979. *Handbook of Ethological Methods*. Garland STPM Press, NY. 403 pp.
- Marks, J.S. P.L. Hendricks, and V.S. Marks. 1984. Winter food habits of Barred Owls in western Montana. *Murrelet* 65:27-28.
- Marti, C.D. 1974. Feeding ecology of four sympatric raptors. *Condor* 76:45-61.
- McGarigal, K. and J.D. Fraser. 1984. The effect of forest stand age on owl distribution in southwestern Virginia. *Journal of Wildlife Management* 48:1393-1398.
- McGarigal, K. and J.D. Fraser. 1985. Barred Owl responses to recorded vocalizations. *Condor* 87:552-553.
- Nicholls, T.H. and D.W. Warner. 1972. Barred Owl habitat use as determined by radiotelemetry. *Journal of Wildlife Management* 32:213-224.
- Rusling, W.J. 1951. Food habits of New Jersey owls. *Proceedings of the Linnaean Society (New York)* 58-62:38-45.
- Russell, E.W.B. 1981. Vegetation of northern New Jersey before European settlement. *American Midland Naturalist* 105:1-12.
- Smith, C.F. 1978. Distributional ecology of Barred and Great Horned Owls in relation to human distribution. M.S. Thesis. University of Connecticut.
- Smith, D.G., A. Devine, and D. Devine. 1983. Observations of fishing by a Barred Owl. *Journal of Field Ornithology* 54:88.
- Smith, D.G. and R. Gilbert. 1984. Eastern Screech-Owl home range and use of suburban habitats in southern Connecticut. *Journal of Field Ornithology* 55:322-329.
- Soucy, L.J., Jr. 1976. Barred Owl nest. *North American Bird Bander* 1:68-69.
- Speiser, R. and T. Bosakowski. 1984. History, status, and future management of the Northern Goshawk in New Jersey. *Records of New Jersey Birds* 10:29-33.
- Speiser, R. and T. Bosakowski. 1987. Nest site selection by Northern Goshawks in northern New Jersey and southeast New York. *Condor*, in press.
- Stearns, E.I. 1947. Notes on the abundance of the Barred Owl. *Urner Field Observer* 2:5-7.
- Stirling, D. 1970. A sight record of the Barred Owl on Vancouver Island. *Murrelet* 51:19.
- Sutton, C.C. and P.T. Sutton. 1985. The status and distribution of Barred Owl and Red-shouldered Hawk in southern New Jersey. *Cassinia* 61:20-29.
- Tyler, H.A. and D. Phillips. 1978. *Owls by day and night*. Naturegraph Publishers, Inc., Happy Camp, Ca.
- Wilson, K.A. 1938. Owl studies at Ann Arbor, Michigan. *Auk* 55:187-197.
- Zar, J.H. 1974. *Biostatistical Analysis*. Prentice-Hall, Inc., Englewood Cliffs, NJ. 620 pp.

Ecology of the Three Species of *Strix* Owls in Finland¹

Heimo Mikkola²

The Tawny, Ural, and Great Grey Owls breed sympatrically in large areas in the USSR, south-eastern Poland, and Finland. In Finland their area of sympatry covers, especially in good vole years, almost the entire southern and central country. This presentation concentrates on four ecological parameters: activity, food, breeding habitat, and nest site.

The southern Tawny Owl is the most nocturnal in the breeding season. The northern limit of its range may be determined by the short summer nights. In contrast, the northern Great Grey Owl is the most diurnal species, which has adapted to light summer nights in its central range by being active throughout the day and night, only ceasing to feed its young in the afternoon. The Ural Owl has an intermediate position, showing a biphasic activity, with the highest peak in the late evening and lower peak in the early morning, and, to a small extent, remaining active also during the day.

The Great Grey Owl, which is the largest, is a small rodent specialist. Both Ural and Tawny

Owls are catholic predators and food generalists. Their food niches are about 2.5 times broader than that of the Great Grey.

Great Grey Owl breeding habitat is the most catholic among the three; it breeds in forests of all kinds. Habitat selection of the Tawny is the most restricted, but overlaps extensively with that of the Ural Owl. The Tawny Owl is almost exclusively a hole-nester (92% of nest sites studied), while nest selection by the Ural Owl is quite catholic, including nest boxes and holes (53%), stumps (23%), and twig nests (20%). The Great Grey Owl uses mainly twig nests (79%) and stumps (13%), and may even lay eggs on the ground (3%). Therefore, Great Grey and Tawny Owls are not competing for the same nest sites, while competition for nest sites may be keen between Ural and Tawny Owls. Occasional competition between Great Grey and Ural Owls may also occur.

As measured by the four aforementioned parameters, the Ural Owl has the widest niche, that of Tawny being 73% and that of the Great Grey only 48% of the niche of the first-mentioned. These results suggest that competition among the three species is common, and should be taken into account when providing artificial nest sites. Favouring one of the species may harm another. Similar competition is likely to exist between Barred and Spotted Owls, but more research is needed to quantify these niche relationships.

¹ Summary of paper presented at the symposium, Biology and Conservation of Northern Forest Owls, Feb. 2-7, 1987, Winnipeg, Manitoba. USDA Forest Service General Technical Report RM-142.

² Heimo Mikkola is now President of the Board, Fish and Water Research Limited, Nilsia, Finland.

Home Range Size of Hawk Owls: Dependence on Calculation Method, Number of Tracking Days, and Number of Plotted Perchings¹

Bjørn T. Bækken, Jan O. Nybo, and Geir A. Sonerud²

Abstract.---Three nesting males and two non-nesting females of the Hawk Owl were equipped with radio transmitters and tracked for 3-11 weeks during 1984-85 in the northern boreal zone of southeast Norway. Home range sizes were larger when calculated by the convex polygon method than when calculated by the quadrature method (squares of 250 m x 250 m). Home range size as calculated by the convex polygon method increased with number of tracking days, while that calculated by the quadrature method increased with number of perchings plotted.

INTRODUCTION

The introduction of radio telemetry has made it possible to sample data on home range use of animals that move over large areas. Some of the first studies making use of this technique dealt with owls (Nicholls and Warner 1972, Forbes and Warner 1974). Since then several studies on the ecology of owls involving radio telemetry have been conducted, mainly in North America. In Europe few such studies have been made (Nilsson 1977, 1978, Wijnandts 1984, Sonerud et al. 1986, Jacobsen and Sonerud 1987).

Shape and size of recorded home ranges for owls may vary depending on several factors connected with data sampling and calculation method. For instance, it may differ depending on whether the owls are located during their usually nocturnal hunting or during their diurnal roosting (Wijnandts 1984, Jacobsen and Sonerud 1987), and may also depend on sample size and sampling interval (Swihart and Slade 1985), and the calculation method (Föhrenbach 1984).

Hawk Owls *Surnia ulula* search for food also during the day (e.g. Glutz von Blotzheim and Bauer 1980). Hence, a realistic estimate of their home range size should be obtainable by diurnal radio-tracking only, in contrast to e.g. Tengmalm's Owls *Aegolius funereus*, for which diurnal and nocturnal activity level, and therefore also home ranges, differ markedly (Jacobsen and Sonerud 1987). Here we report the home range sizes of 5 Hawk Owls as calculated by two dif-

ferent methods, and relate these estimates to the sample sizes, viz. number of days tracking the owl and number of owl perchings plotted.

STUDY AREA

The study was conducted during 1984-85 within an area of 70 km² at an altitude of 520-720 m in the northern boreal zone (sensu Anonymous 1977) in Hedmark county, southeast Norway (61°00'N, 11°10'E). The study area consists of coniferous forest with Norway Spruce *Picea abies* dominating, mixed with bogs and fens. The area is usually covered by snow from mid-November to mid-May. In 1984 the snow-melt occurred extremely early, and in 1985 extremely late, with clearcuts being snow-free May 1 and 25, respectively.

METHODS

Three male Hawk Owls trapped in mist nets at the nest site (M1 in 1984, M2 and M3 in 1985), and two female Hawk Owls trapped in a bow-net outside the nesting season (F1 in 1984 and F2 in 1985), were equipped with radio transmitters (Biotrack, England) mounted as a back-pack (fig. 1), and tracked 3-11 weeks (table 1). The tracking was conducted during daytime by first localizing, and then following, the hunting owls by walking or skiing, using a hand-held receiver (Televilt, Sweden) and a 4-element yagi-antenna. All observed perchings of the owls were plotted on aerial photos with scale 1:15,000 in the field, and later plotted on maps with scale 1:5,000. Since an important aim of the tracking was to sample data on the foraging behavior of the owls, each owl was followed as continuously as possible for several hours per day. The average number of perchings plotted per day varied from 2-54 for the five owls, with an average of 19. Hence, the plottings of perched owls were to a large extent autocorrelated, and

¹Paper presented at the symposium, Biology and Conservation of Northern Forest Owls, Feb. 3-7, 1987, Winnipeg, Manitoba. USDA Forest Service General Technical Report RM-142.

²Bjørn T. Bækken and Jan O. Nybo are Graduate Students and Geir A. Sonerud is Research Associate, Department of Biology, Division of Zoology, University of Oslo, Oslo, Norway.

only non-statistical methods could be employed for estimating home range size as long as all plotted perchings were included (see Swihart and Slade 1985). Therefore, home range sizes were calculated in two ways: 1) By the convex polygon method (Mohr 1947, Föhrenbach 1984), and 2) by the quadrate method (Föhrenbach 1984), dividing the home range into squares (250 m x 250 m) and counting all squares with plottings of perched owls.

We tried to generate more independent, i.e. less autocorrelated, plottings by limiting the sample size to only the first plotting each tracking day. However, this decreased the sample size of some of the owls to such an extent that the calculated home range size amounted to only a small fraction of the size calculated when all plottings were used. Therefore, we included all plotted perchings of the Hawk Owls in our calculations of home range size. Swihart and Slade (1985) also found that over a specified time frame nonstatistic estimates became increasingly accurate with increasing sample size, even when autocorrelation increased.



Figure 1.--Hawk Owl M3 is released after being equipped with a radio transmitter. Photography by G.A. Sonerud.

Table 1.--Home range size, as estimated by the convex polygon method and the quadrate method, for 5 Hawk Owls (M=male, F=female), with tracking period, number of tracking days, and number of plotted perchings shown.

Owl	Tracking period	Home-range size (ha)		Tracking effort	
		Polygon	Quadrate	Days	Plotted perchings
M1	May 28- June 22/84	390	344	12	653
F1	Sept. 15- Nov. 6/84	264	275	12	276
F2	Jan. 10- March 28/85	848	156	22	42
M2	April 29- June 6/85	217	131	7	57
M3	May 15- June 5/85	140	106	5	59

RESULTS

Home range size of the five Hawk Owls varied from 140-848 ha, with an average of 372 ha (S.D. = 281), when calculated by the convex polygon method, and from 106-344 ha, with an average of 202 ha (S.D. = 102), when calculated by the quadrate method (table 1). The home range sizes calculated by the convex polygon method were almost significantly larger than those calculated by the quadrate method (table 1; $T_S=1$, $n=5$, $p=0.06$, Wilcoxon's matched pairs signed-ranks test (Sokal and Rohlf 1969)), and there was no significant correlation between the home range sizes as calculated by the two methods (table 1; $r_S=0.07$, $n=5$, $p>0.1$, Spearman's rank correlation test, one-tailed (Siegel 1956)). However, if we exclude the owl tracked when the ground was snow-covered (F2) there was a significantly positive correlation between home-range sizes as calculated by the two methods (table 1; $r_S=1.00$, $n=4$, $p<0.05$). The shape and relative size of the home range of each owl as calculated by the two methods are shown in figure 2.

Cumulative home range size as calculated by the convex polygon method levelled off during the tracking period for all individuals except F2 (fig. 3). This suggests that the total home range size found was close to the real one for the three nesting males tracked as well as for the female tracked during autumn, but possibly not for the female tracked during winter. Total home range size as calculated by the polygon method was significantly linearly correlated with number of tracking days ($r=0.97$, $n=5$, $p<0.01$ (Sokal and Rohlf 1969)), while the total home range size as calculated by the quadrate method was not ($r=0.21$, $n=5$, $p>0.1$). There was no significant linear correlation between home range size as calculated by the polygon method and the number of plotted perchings ($r=-0.07$, $n=5$, $p>0.1$). However, the linear correlation between total home range size, as calculated by the quadrate method, and number of plotted perchings was significant ($r=0.94$, $n=5$, $p<0.01$).

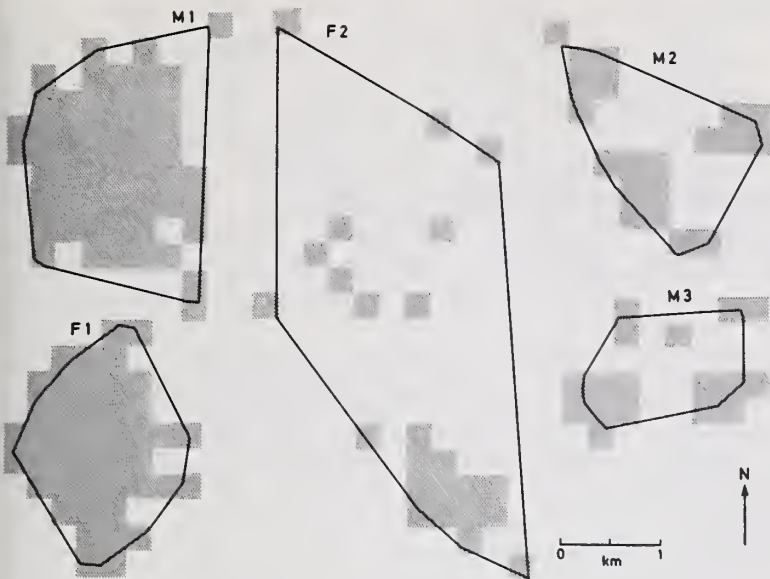

Figure 2.--Relative size and shape of the recorded home ranges of 5 Hawk-Owls (M=male, F=female) as calculated by the convex polygon method (solid line) and the quadrate method (shaded squares).

DISCUSSION

Home range size varied substantially among the 5 Hawk Owls, especially when calculated by the convex polygon method. Great individual variation in home range size was also found in Barred Owl *Strix varia* (Nicholls and Warner 1972), Wolverine *Gulo gulo* (Whitman et al. 1985) and Bobcat *Felis rufus* (Fuller et al. 1985). This may be explained by different home range use by the sexes (Whitman et al. 1986), or by sampling data in different seasons (Fuller et al. 1985). Nicholls and Warner (1972) found that Barred Owls had a strong preference for certain habitat types and avoidance of others, so that the home range size may have depended on the spacing of preferred habitat patches. In our study, most of the variation in home range size may be explained by differences in the sample sizes between individuals.

There was a positive linear correlation between the convex polygon home range size and the number of tracking days. The cumulative home range size clearly levelled off for the two individuals tracked for 12 days each, indicating that this effort may give a good estimate of an Hawk Owl's home range size. The large home range size, as calculated by the convex polygon method, for one female was mostly due to a home range shift in the last part of the tracking period. This was the only Hawk Owl that was followed during the winter. Similarly, the cumulative home range sizes of 3 Eastern Screech Owls *Otus asio* in Connecticut, USA, and one Tengmalm's Owl in Norway, continued to increase throughout the time monitored (Smith and Gilbert 1984, Jacobsen and Sonerud 1987). Further, microtine rodent prey are less available on snow-covered than on snow-free ground (Sonerud 1986), and this should induce a larger home range in winter than in other seasons.

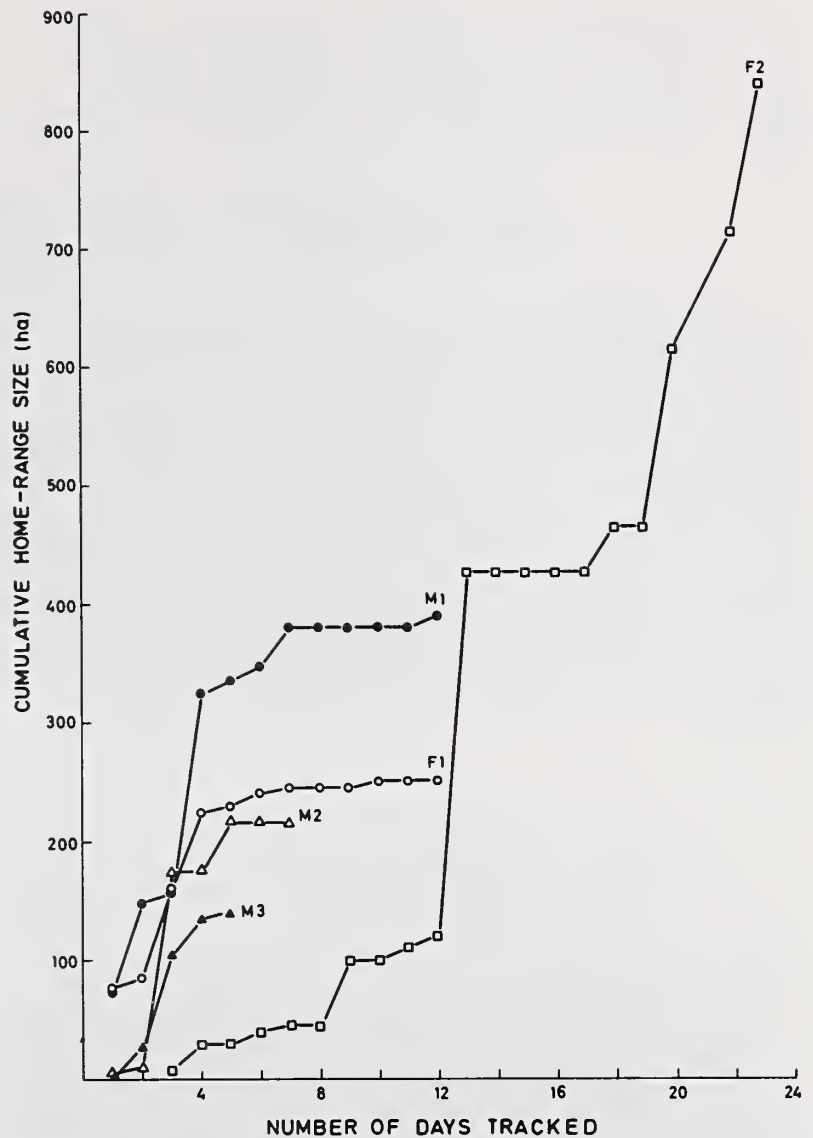

Figure 3. Cumulative home range size for 5 Hawk Owls, as calculated by the convex polygon method, in relation to number of days tracked (M=male, F=female).

There was a positive linear correlation between the quadrate home range size and the number of plotted perchings. The quadrate method considers only which parts of the polygon convex home range that are observed being used. Since the use of the different squares within the convex polygon home range is non-random (B.T. Bækken, J.O. Nybo and G.A. Sonerud, unpubl.), the number of squares used will be far less than the number of perchings plotted. Hence, with the square-size employed (16 per km²), more than a hundred plotted perchings seems necessary in order to obtain a quadrate-based home range covering the convex polygon-based one.

The home ranges of the Hawk Owls were larger when calculated by the convex polygon method than when calculated by the quadrate method. The same difference was found for home ranges of Stone Martens *Martes foina* (Föhrenbach 1984). The convex polygon method should be used to obtain an estimate of the home range size of Hawk Owls, because this estimate is dependent on the number of days tracking, but not on the number of plotted perchings. The quadrate method should on the other hand be used when analyzing such topics as

search strategies and habitat selection. Sufficient effort for an accurate estimate during the snow-free season seems to be approximately 10 days, with approximately 10 perchings plotted per day.

ACKNOWLEDGEMENTS

We thank P.E. Fjeld and B.V. Jacobsen for assistance during the field work, and the land owner A. Solberg for kindly allowing us to use the study area and for providing free accommodation. We also thank B. Danielson for improving the English, M. Aas for typing the manuscript, and E. Kresse for drawing the figures. The radio-tracking equipment was financed by grants to G.A. Sonerud from the University of Oslo, the Norwegian Research Council for Sciences, and the Humanities (NAVF), and the Nansen Foundation. The field work was supported by grants to B.T. Bækken and J.O. Nybo from the Robert Collett legacy.

LITERATURE CITED

- Anonymous. 1977. Naturgeografisk regioninndeling av Norden. Nordiske Utredninger B 34: 1-137 (In Danish, Norwegian and Swedish with summaries in English and Finnish).
- Föhrenbach, H. 1984. Notes on several home-range calculation methods shown for Stone Martens, Martes foina (Carnivora, Mustelidae). Säugetierkündliche Mitteilungen 32: 49-53.
- Forbes, J.E., and D.W. Warner. 1974. Behavior of a radiotagged Saw-whet Owl. Auk 91: 783-795.
- Fuller, T.K., W.E. Berg, and D.W. Kuehn. 1985. Bobcat home-range size and daytime cover-type use in northcentral Minnesota. Journal of Mammalogy. 66: 568-571.
- Glutz von Blotzheim, U.N., and K.M. Bauer. 1980. Handbuch der Vögel Mitteleuropas, Vol. 9. Akademische Verlagsgesellschaft, Wiesbaden.
- Jacobsen, B.V., and G.A. Sonerud. 1987. Home range size of Tengmalm's Owl Aegolius funereus: a comparison between nocturnal hunting and diurnal roosting. This issue.
- Mohr, C.O. 1947. Table of equivalent populations of North American small mammals. American Midland Naturalist 37: 223-239.
- Nicholls, T.H., and D.W. Warner. 1972. Barred Owl habitat use as determined by radiotelemetry. Journal of Wildlife Management 36: 213-224.
- Nilsson, I.N. 1977. Hunting methods and habitat utilization of two Tawny Owls (Strix aluco L.). Fauna och Flora 72: 156-163. (In Swedish with summary in English).
- Nilsson, I.N. 1978. Hunting in flight by Tawny Owls Strix aluco. Ibis 120: 528-531.
- Siegel, S. 1956. Nonparametric statistics for the behavioral sciences. McGraw-Hill Kogakusha, Tokyo.
- Smith, D.G., and R. Gilbert. 1984. Eastern Screech-Owl home range and use of suburban habitats in southern Connecticut. Journal of Field Ornithology 55: 322-329.
- Sokal, R.R., and F.J. Rohlf. 1969. Biometry. Freeman, San Francisco.
- Sonerud, G.A. 1986. Seasonal changes in diet, habitat, and regional distribution of raptors that prey on small mammals in boreal zones of Fennoscandia. Holarctic Ecology 9: 33-47.
- Sonerud, G.A., R. Solheim, and B.V. Jacobsen. 1986. Home-range use and habitat selection during hunting in a male Tengmalm's Owl Aegolius funereus. Fauna Norvegica, Ser. C, Cinclus 9: 100-106.
- Swihart, R.K., and N.A. Slade. 1985. Influence of sampling interval on estimates of home-range size. Journal of Wildlife Management 49: 1019-1024.
- Whitman, J.S., W.B. Ballard, and C.C. Gardner. 1986. Home-range and habitat use by Wolverines in southcentral Alaska. Journal of Wildlife Management 50: 460-463.
- Wijnandts, H. 1984. Ecological energetics of the Long-eared Owl (Asio otus). Ardea 72: 1-92.

Observations of the Northern Hawk Owl in Alberta¹

Edgar T. Jones²

Abstract. A discussion of general range and diurnal hunting habits, including observations in the MacKenzie Delta, N.W.T. Canada. An outline is given of observations made during the discovery of four nests indicating nest site variation and feeding habits of both sexes. Dates of nestings for Alberta region are outlined. Winter hunting techniques are discussed, along with encounters with the species using fishing rod and mouse in the early 1960's.

INTRODUCTION

This paper is a collection of my personal observations from the early 1950's to 1974. I discovered my first nest in Flatbush, Alberta, Canada in 1952.

RANGE

The range of this owl in Canada extends across the boreal forest zone from the Yukon and Alaska west to Newfoundland. The breeding range extends north to the treeline and as far south as central Alberta and south-central Ontario. I have seen several Hawk-Owls along the channels of the MacKenzie delta 100 miles inside the Arctic circle. I have also encountered the species at 1700 meters (5500 feet asl) in the dead of winter in Banff National Park.

In winter, the habitat becomes more varied as this bird tends to seek out open areas of parkland where the fields are bordered with small poplar. The fringes of muskeg are a favorite winter/spring haunt, particularly in the latter part of winter when the pairs start to set out their breeding territory. A

larger part of its breeding range is in the area of 24 hour daylight, and the bird is largely diurnal; even in the short days of winter, it hunts during daylight hours.



Figure 1. A hunting Hawk-Owl surveys a grassy muskeg clearing from the top of a black swamp spruce (*Picea mariana*) in northern Alberta, Canada.

¹Northern Forest Owl Symposium. February 3-7, 1987. Viscount Gort Hotel, Winnipeg, Manitoba, Canada.

²Edgar T. Jones, Wildlife Photographer/Naturalist/Artist. 6115 - 141 Street Edmonton, AB. T6H 4A6, Canada.

IDENTIFICATION

Several characteristics quickly differentiate this species from other owls. When hunting, its habit of perching on the tip of the tree rather than half way down or on a lower branch, is very consistent. Even when it is sitting on small poplars or willows, it displays a horizontal stance rather than an upright stance as most owls tend to take. The long tail and its habit of flicking it, in a manner similar to the Kestrel, are two important characteristics. I have seen it hovering on two occasions, another unexpected trait that separates this owl from other species. As for sound, in my association with these birds, I have found them to be very quiet. I have only heard the occasional feed call when I was near the nest site and have never heard any calls while the birds were hunting.

FOOD AND HUNTING TECHNIQUES

During the breeding season, its food generally consists of small mammals such as red-backed and meadow voles, and deer mice. Undoubtedly some small birds are also taken, but certainly in the wintering areas voles and deer mice would be the most likely prey. I would suspect that redpolls, snow buntings and other smaller wintering species would be part of the winter food fare but I have not personally observed this.

They have acute hearing and extremely keen eyesight. On one occasion I watched a Hawk-Owl hunting from the top of a 6 meter (20 feet) black spruce after a deep, soft snowfall. The bird cocked its head to the side several times and then literally dropped off of the spruce into the deep snow. Only the tips of the wings and tail were visible and yet within a few seconds the bird flew up to the tree clutching a vole. This catch was obviously made by sound only as the vole was at least one foot below the snow surface.

In the early 1960's I attracted Hawk-Owls into close range for photography by using a dead mouse as a lure. The mouse was tied to a monofilament line and, with the aid of a spinning rod, cast out onto the snow surface. It soon became evident that a hunting Hawk-Owl could see the mouse up to 730 meters (800 yards) away. The owl would leave its perch and head toward the mouse even before it could be reeled in more than 3 meters (10 feet).

A friend, Bob Gehlert of Edmonton, Canada, developed a technique in the early 1960's which has allowed him to catch and band almost one hundred Hawk-Owls over the last 25 years. His technique simply involved releasing a live house mouse at his feet when a Hawk-Owl was spotted. Within a second or two the owl would head for the mouse. As it came near the mouse he used a fish-landing net to intercept and catch the owl within a meter or so of where he stood. Timing was critical in order to save the mouse for another catch. This demonstrates the incredible fearlessness of this little owl and its concentration on the prey target.

BREEDING AND NESTING AREAS

In north-central Alberta, this bird is considered an early nester. I have found that they are usually on their nesting territory by mid-March and start to lay in mid-April. The following are the dates I have from my nesting records:

April 25, 1952: 6 eggs. This nest was in a burnt out tamarack stump at 6 meters (20 feet). The five young were ready to leave on May 24th.

May 15, 1970: Five young were found feathering out in a nest located in a spruce snag at 6.7 meters (22 feet).

May 17, 1970: We caught and banded the female at a nest which was at 9 meters (30 feet) in a live Balsam Poplar where a branch had broken off leaving a hole. There were seven young between ten to 12 days old. On May 23rd, at this same nest a different adult was caught and banded along with four of the six young remaining in the nest. The two young not banded were too small to retain the band.

June 6, 1975: My associate, Bob Gehlert, found a nest at 4.3 meters (14 feet) in a burnt out spruce stump containing two half-grown young. This nest was in a dense spruce much less open than other locations.

Finding the nest is relatively simple once the breeding territory or the male by himself has been located. By watching the male carefully, when prey has been caught, the male flies directly to the nest so that once this line of flight has been established it is a matter of following it for 90 to 450 meters (100-500 yards) until the nest site is located. The male brings prey to the female on the nest. She may leave briefly to take it from the male either at the nest entrance or a short distance away. If there are young in the nest, the female will return directly to the nest with the food. All this will often be done with an observer close by as the birds have little or no obvious fear of

man.

The nesting site varies with the nests I have observed, but it is usually in or on the fringe of a muskeg. Some sites are in dense Black Spruce, others are in open locations. The most favored location seems to be a burnt out stump with a hole at any height from two to nine meters (8-30 feet). Apparently this species sometimes nests in an old crow's or hawk's nest, but I have never personally observed this. The clutch size varies from three to seven, but usually is five or six.

A word of warning to anyone attempting to climb the nest stump or tree: The Hawk-Owl will not hesitate to attack an intruder.

ENEMIES

Its greatest enemy, without question, is man. The annual destruction of thousands of acres of potential breeding territory, much of which is marginal agricultural land, is the greatest contributing factor to the ever retreating breeding area of the Hawk-Owl, at least in Alberta, Canada.

BANDING RESULTS

Bob Gehlert reports several Hawk-Owls that have been recaptured, some from the same tree and several from the same immediate area where the birds were originally banded. I have not received any returns from the ones I have banded.

Foraging Activity and Growth of Nestlings in the Hawk Owl: Adaptive Strategies Under Northern Conditions¹

Kauko Huhtala, Erkki Korpimäki, and Erkki Pulliainen²

Abstract.--Foraging activity was recorded at four nests of the Hawk Owl *Surnia ulula* in C. and N. Finland. The owls brought food to the nest throughout the day, apart from a 2-3 hour pause around midnight. The frequency of nest visits was greatest in early morning (3-4 a.m.), around noon (11 a.m.-1 p.m.) and in late evening (8-11 p.m.). The parent owls visited the nest an average of 10.6 times per day during the incubation period, increasing their visits to 16.6 per day during the hatching period and to 41.4 during the nestling period. They also brought food from the nest to store in its immediate vicinity. The nestlings clearly invested in increasing their body weight at the early stage of the nestling period, the growth of the wings being rather slow. The foraging and growth strategies of the Hawk Owl show adaptation to harsh northern conditions, with continuous daylight, variable food resources and relatively few competitors.

INTRODUCTION

The distribution of nesting Hawk Owls, *Surnia ulula*, is concentrated in the north-boreal zone of the northern hemisphere (for distribution map, see Mikkola 1983) to such an extent that it can be expected that special strategies should have evolved to ensure their success in these adverse and in some respects unpredictable conditions. Because the species also nests in areas characterized by continuous daylight, it has been suggested that it is day-active (Mikkola 1972). Although the hole-nesting Hawk Owl is rather easy to study, surprisingly little is known about its biology, and this is also true of its foraging activity and the growth of its nestlings which we intend to describe in this contribution.

MATERIAL AND METHODS

Visits by the Hawk Owls to four nests were recorded as follows:

1) Direct observations were made from a hide at a nest in Värriö Nature Park (67.5°N, 29.5°E), E. Finnish

Forest Lapland, for two days during the hatching period in 1982. Small rodent populations in that year may be described as "average".

2) Nest visits were recorded by an automatic recorder (type "Norma", see Korpimäki and Huhtala 1986) from the laying period to the end of the nestling period at Ylivieska, (64°N, 24.5°E), W. Central Finland, in 1974. Local small rodents were at their peak in that year.

3) Nest visits were recorded with an automatic recorder during the incubation period (7 days) and hatching period (10 days) at Kauhava, (63°N, 23°E), W. Central Finland, in 1977. This nest was later lost for some unknown reason. Local small rodent populations were at their peak.

4) Nest visits were recorded during the incubation period (8 days) and nestling period (16 days) at Kauhava in 1986. The young in this nest were also weighed on a Pesola spring balance and their wing lengths were measured every other day. A recorder made from a tachograph was used at both nests at Kauhava (see Korpimäki 1981).

RESULTS

The Hawk Owls visited their nests throughout the day, apart from a 2 or 3 hours pause around midnight (figs. 1-3), the length of which was reduced by the need to feed the nestlings (see especially fig. 3). The frequency of the visits varied in periods of 2-3 hours, with peaks in the early morning (3-4 a.m.), around noon (11 a.m.-1 p.m.) and in the late evening (8-11 p.m.) (figs. 1-3). Here again the variation seems to decrease during the nestling period (figs. 1 and 3).

¹Paper presented at the symposium, Biology and Conservation of Northern Forest Owls, Feb. 3-7, 1987, Winnipeg, Manitoba. USDA Forest Service General Technical Report RM-142.

²Kauko Huhtala is Assistant of Zoology, Erkki Korpimäki is Researcher of the Academy of Finland, and Erkki Pulliainen is Professor of Zoology at the Department of Zoology, University of Oulu, Oulu, Finland.

The need to visit the nest naturally depends on the stage of the breeding process, the number of visits increasing from the incubation period towards the end of the nestling period. The owls visited the nest an average of 10.6 times per day during the incu-

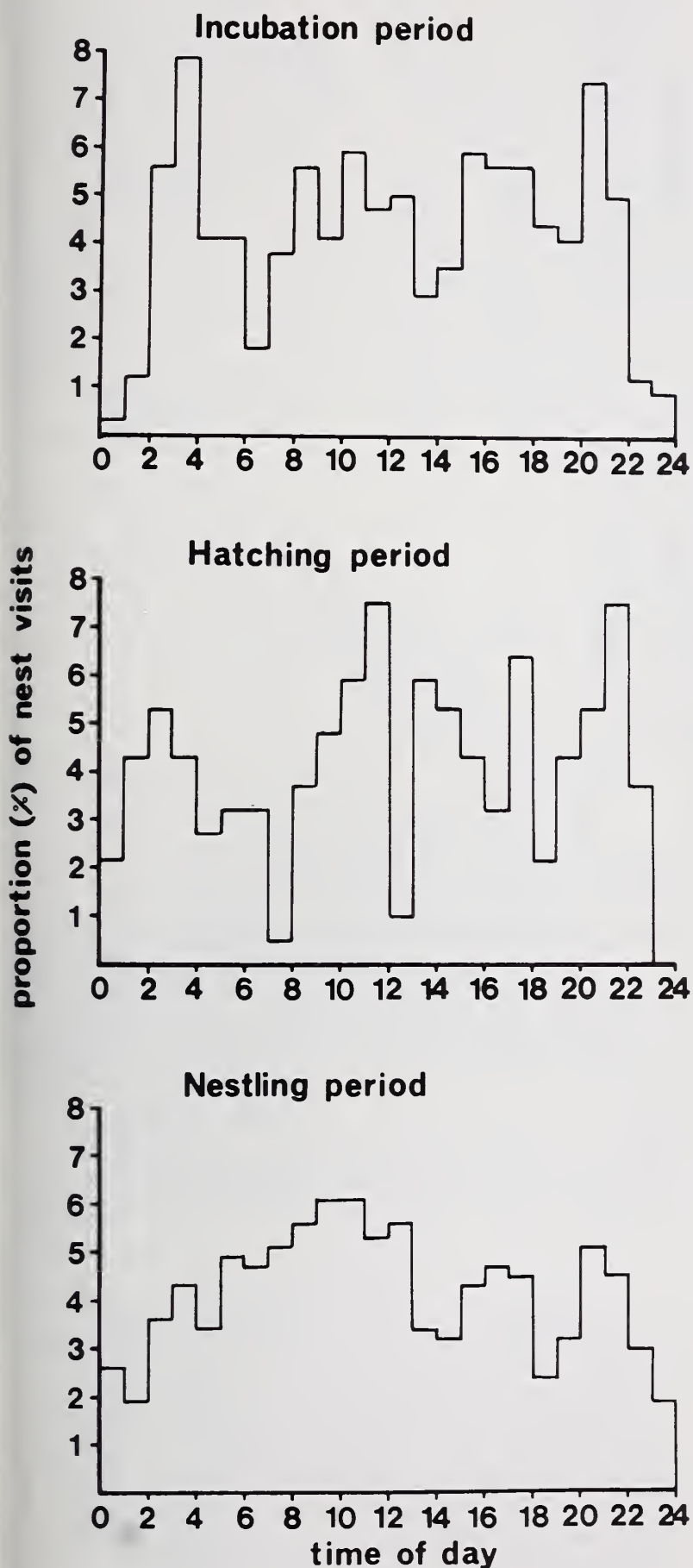

Figure 1.--Diurnal pattern of nest visits of Hawk Owls at Ylivieska in 1974 during the incubation (above), hatching (middle) and nestling periods (below).

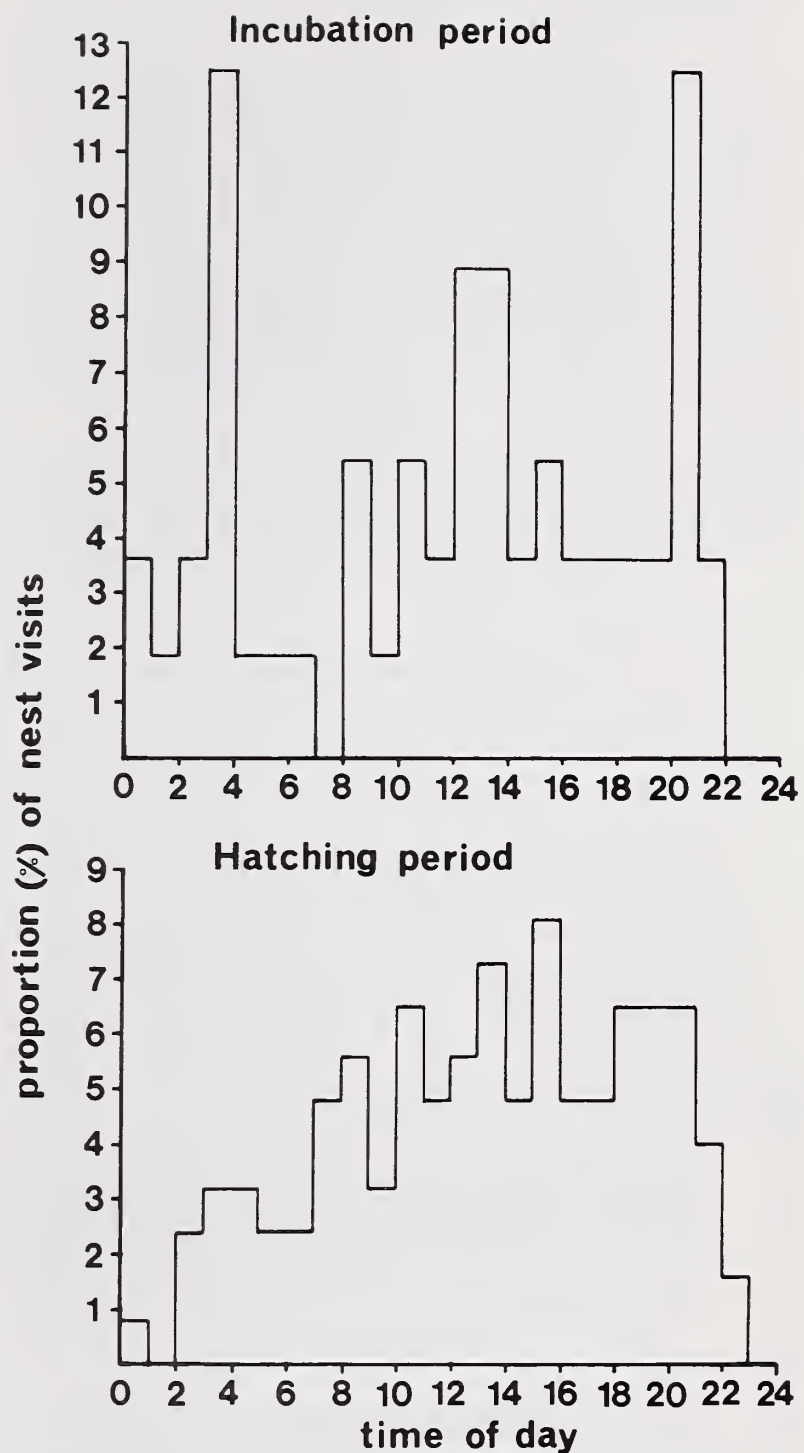

Figure 2.--Diurnal pattern of nest visits by Hawk Owls at Kauhava in 1977 during the incubation (above) and hatching periods (below). The mean number of visits per day was 8.0 ± 1.2 ($N = 7$) during incubation and 12.4 ± 2.2 ($N = 10$) during hatching.

bation period, but not only in order to incubate or bring food, because the observations made in the Värriö Nature Park also suggest that they took food from the nest to nearby cache sites (2-3 times/day by the males). The mean number of visits to the nest increased to 16.6 during the hatching period, and to 41.4 during the nestling period, with a further increase in the course of the nestling period, the number varying between 20 and 30 at first, but between 40 and 50 by the time the young were 16-20 days old. Once the young had passed the stage of rapid weight increase nest visits by their parents decreased (fig. 4). The present data also suggest that there may be some variation between parent birds in this respect

(fig. 1 versus figs. 2-3) which may be due to differences in caching behaviour, in cleaning of the nest, or in the abundance of food available.

The newly hatched young of the Hawk Owl weigh about twice as much as those of its smaller relative, Tengmalm's Owl, *Aegolius funereus*, but their wings are only 2 mm longer (table 1). The nestlings tend to increase in weight very rapidly during the first 2.5 weeks of their lives (fig. 4), an average of 9 g/day, which is three times the rate of Tengmalm's Owl at the same age. In contrast, wing length increases only 1.5 times as much as in Tengmalm's Owl nestlings. The wings of young Hawk Owls grow throughout the nestling period, but their weight gain ceases at the age of 2.5 weeks (fig. 4). They leave the nest at the age of 3-4 weeks, having achieved 78 % of the weight of their parents, but only 60 % of their parents' wing length (table 1). In the case of Tengmalm's Owl the situation is different when leaving the nest, at the

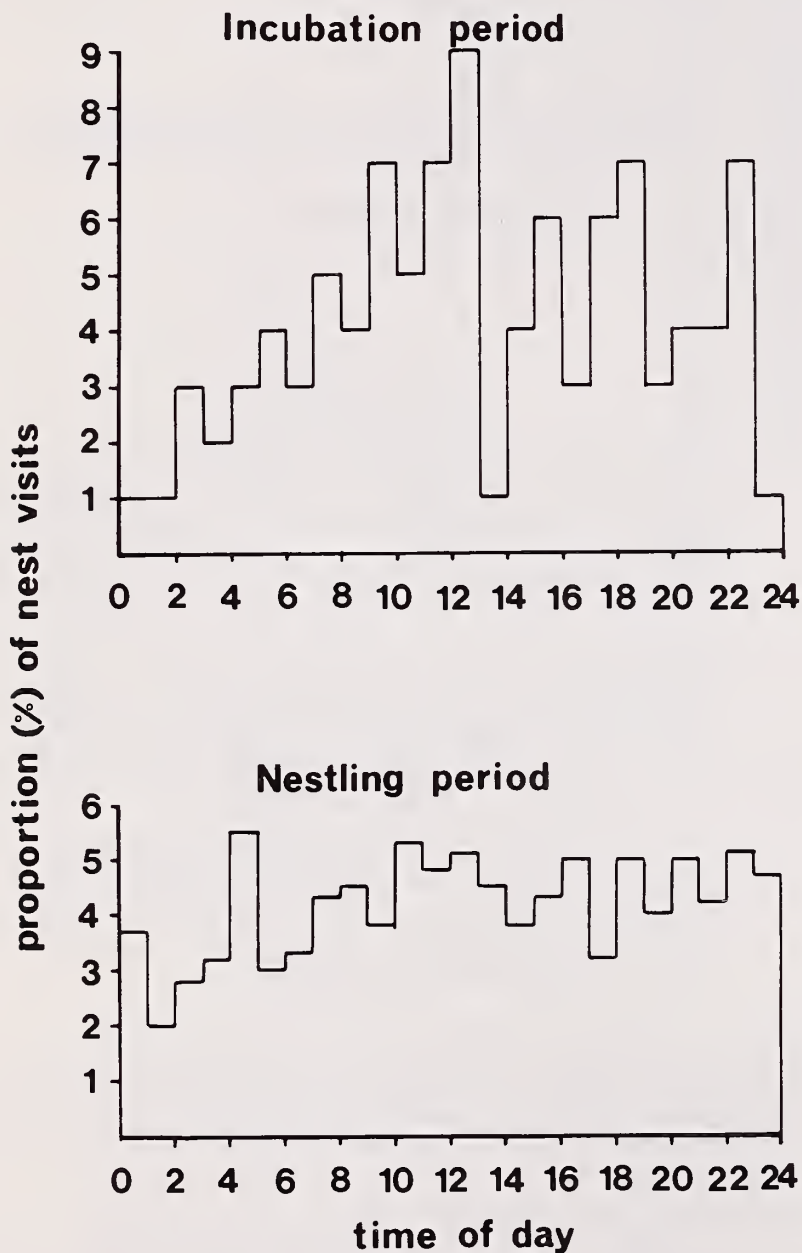

Figure 3.--Diurnal pattern of nest visits by Hawk Owls at Kauhava in 1986 during the incubation (above) and nestling periods (below). The mean number of visits per day was 10.8 ± 2.7 ($N = 8$) during incubation and 37.7 ± 7.3 ($N = 16$) during the nestling period.

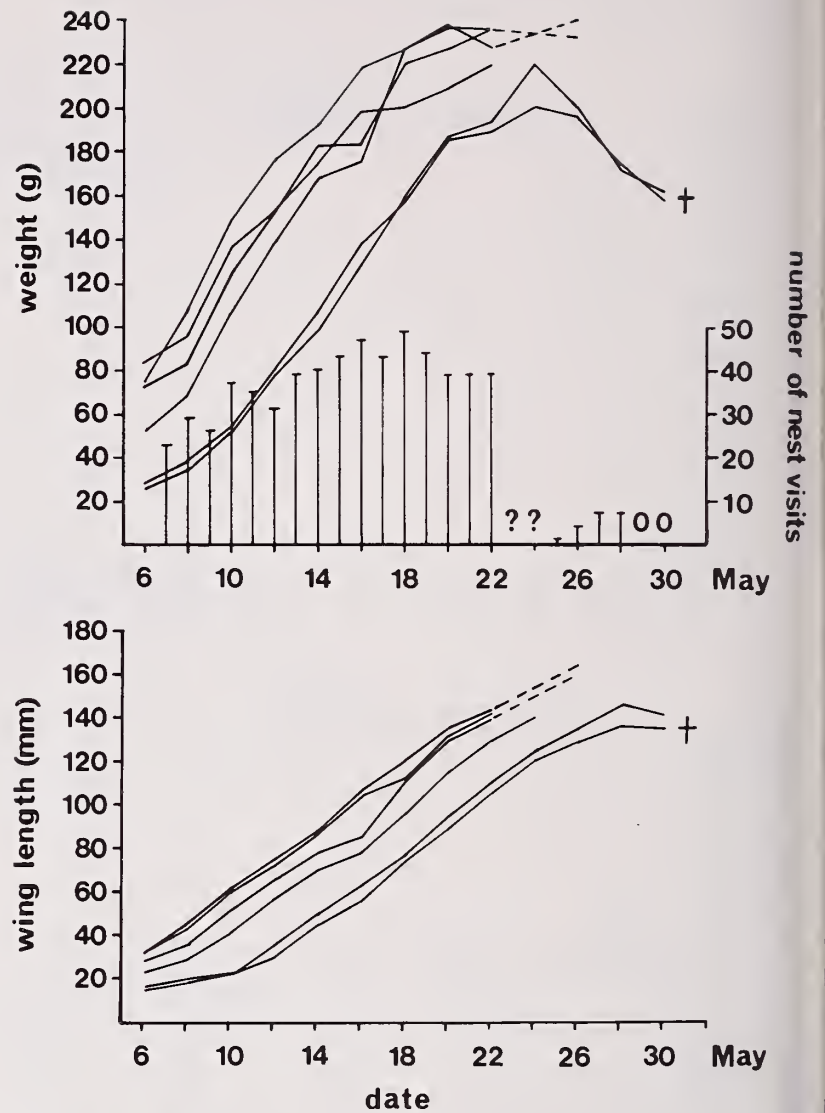

Figure 4.--Weight gain (above) and wing growth (below) in Hawk Owl nestlings compared with the number of daily nest visits by the parent owls (above, columns) at Kauhava in 1986. The cross denotes a young that died in the nest. ? = recorder was not functioning, 0 = no visits to the nest.

age of 4.5 weeks. The young are able to fly, their weight is 91 % of that of their parents and their wing length is 71 % of that of their parents (table 1).

DISCUSSION

An automatic recorder installed at an owl's nest does not tell what kind the visit has been recorded, since feeding trips leave similar marks to trips when the owl carries away food remains or pellets. Female owls also defecate outside the nest, so that a female Great Grey Owl, *Strix nebulosa*, for instance, leaves the nest 3.1 times/day on average during the incubation period and 3.7 times/day during the nestling period (Pulliainen and Loisa 1977). The corresponding figure for Tengmalm's Owl is 2.1/day (Korpimäki 1981). A female Hawk Owl eats the pellets produced by the nestlings during the hatching period (Leinonen 1978). The direct observations made in the Värriö Nature Park comprised only feeding or caching events,

Table 1.--Growth of nestlings of the Hawk Owl compared with that of nestlings of the Tengmalm's Owl. Sources in parentheses.

	Hawk Owl		Tengmalm's Owl	
Weight of adults (g, mean of female and male)	295	(1)	134	(2)
Wing length of adults (mm, mean of female and male)	236	(1)	173	(2)
Mean nestling period (days)	23	(3)	32	(2)
Mean weight of young (g)				
at hatching	18	(3)	9	(2)
at fledging	230	(3)	122	(2)
Mean weight gain of nestlings per day (g)	9.2	(3)	3.5	(2)
Weight of fledglings as % of adult weight	77.9	(3)	91.2	(2)
Mean wing length (mm)				
at hatching	13	(3)	11	(2)
at fledging	141	(3)	124	(2)
Mean wing growth of nestlings per day (mm)	5.6	(3)	3.5	(2)
Wing length of fledglings as % of that of adults	59.7	(3)	71.7	(2)

Sources: (1) Mikkola (1983), (2) Korpimäki (1981) and unpubl., and (3) this study.

which means that the activity recorded mainly describes the feeding by the parent owls.

It can be expected that a bird of prey, such as the Hawk Owl, which mainly feeds on small rodents in the continuous daylight and unpredictable conditions of the north, develops a strategy which takes full benefit of this daylight period for catching its prey and for ensuring that the nestlings grow as rapidly as possible. When the decision to breed has been made by the parents on the basis of the local small rodent population, it is important to use this natural resource as rapidly as possible, since there are other simultaneous users of the same resource.

The present data show that Hawk Owls made efficient use of the long daylight period for catching prey and feeding their nestlings (figs. 1-3). They also collect small rodents to store nearby, to be available for intensive feeding of the young. This efficiency is reflected in the clutch size and general productivity of the species as compared with other owl species of the north-boreal zone (data from Mikkola 1983). This result is the product of hard work, however, as the Hawk Owl visits its nest 3-4 times more often than any of the other north-boreal owls; Tengmalm's Owl doing so 8.3 times/day during the nestling period (Korpimäki 1981), the Ural Owl *Strix uralensis* 13.0 times/day (Korpimäki and Huhtala 1986) and the Great Grey Owl 9.7 times/day (Pulliainen and Loisa 1977).

The northern owls (e.g. *Strix nebulosa*, *Nyctea scandiaca* and *Surnia ulula*) are in general day-active, which is natural, since there is continuous or almost

continuous daylight during most of their breeding season. This may be in contradiction to the optimal foraging theory (see Pyke et al. 1977), because the small rodents show "night-activity" in the spring (for *Clethrionomys* spp., see Pearson 1962, Bergstedt 1965, Mikkola 1970; for *Microtus* spp., see Erkinaro 1969), but the reality of continuous or almost continuous daylight obviously forces the owls to use this time for hunting, and the present data confirm that enough prey is available throughout the day. On the other hand, the number of other day-active birds of prey eating small rodents in the north-boreal zone is low (primarily *Buteo lagopus* and *Stercorarius longicaudus*), which reduces competition as compared with the situation in more southerly areas.

In fact the Hawk Owl appears to hunt when small rodents are available and gather extra prey into stores in the vicinity of the nest (also Leinonen 1978, Ritchie 1980). This allows them to feed their nestlings continuously, providing for rapid growth. On the other hand, the Hawk Owl faces technical problems in this storage process, for the species favours nest holes which are shallow (K. Huhtala, unpubl. data), and these cannot be used as storage sites like those of Tengmalm's Owl are (Korpimäki 1981). The clutch of the Hawk Owl is also larger than that of Tengmalm's Owl, which again detracts from this strategy. But there is also some benefit from a shallow nest hole, since the incubating female may watch over the prey stored in the trees nearby and defend them against robbing by for example corvids (see Thönen 1965). Prey stores are probably a buffer against temporary food shortage caused by, for example, heavy snowfalls. In the breeding season, weather conditions may suddenly deteriorate, for heavy snowfalls may occur in Finnish Forest Lapland up to the beginning of July (Pulliainen 1978). Ritchie (1980) assumed that the establishment of caches may provide a key to more efficient division of duties between female and male, and may also reduce potential conflicts of parents at the nest. If these were the main points, this kind of cache behaviour would have developed in all the owl species and would not be confined to the northern owls (see also Korpimäki, in press).

Due to limited space in the nest hole, it is reasonable that the young of the Hawk Owl leave their nest as early as possible. A growing young can invest its energy mainly in body weight or wing growth, or in both simultaneously. The Hawk Owl has selected the first alternative, which could be called the "oilbird (*Steatornis caripensis*) strategy" or "fat-young strategy". They leave the nest at the age of only 3-4 weeks, when they are still unable to fly, but they are skilful climbers and their mother continues to watch over them. This strategy is also safe in that there are relatively few potential enemies in their breeding habitats in the north. This "fat-young strategy" also allows some fasting periods during the fledging period, which may be adaptive in these harsh conditions. This, together with the caches of prey animals, provides the young of the Hawk Owl with some measure of life insurance.

ACKNOWLEDGEMENTS

We wish to thank Timo Hyrsky and Reijo Passinen

for help in the field. Financial support to EK from the Finnish Cultural Foundation, the Emil Aaltonen Foundation and the Academy of Finland is gratefully acknowledged.

LITERATURE CITED

- Bergstedt, B. 1965. Distribution, reproduction, growth and dynamics of the rodent species Clethrionomys glareolus (Schreber), Apodemus flavicollis (Melchior) and Apodemus sylvaticus (Linné) in southern Sweden. *Oikos* 16:132-160.
- Erkinaro, E. 1969. Der Phasenwechsel der lokomotischen Aktivität bei Microtus agrestis (L.), M. arvalis (Pall.) und M. oeconomus (Pall.). *Aquilo, Ser. Zool.* 8:1-29.
- Korpimäki, E. 1981. On the ecology and biology of Tengmalm's Owl (Aegolius funereus) in Southern Ostrobothnia and Suomenselkä, western Finland. *Acta Univ. Oul. A* 188. *Biol.* 13:1-84.
- , in press. Prey caching of breeding Tengmalm's Owls Aegolius funereus as a buffer against temporary food shortage. *Ibis* 129.
- and Huhtala, K. 1986. Nest visit frequencies and activity patterns of Ural Owls Strix uralensis. *Ornis Fenn.* 63:42-46.
- Leinonen, A. 1978. Hawk Owl breeding biology and behaviour at nest. *Lintumies* 13:13-18. (In Finnish with summary in English).
- Mikkola, H. 1970. On the activity and food of the Pygmy Owl Glaucidium passerinum during breeding. *Ornis Fenn.* 47:10-14.
- 1972. Hawk Owls and their prey in northern Europe. *British Birds* 65:453-460.
- 1983. Owls of Europe. T & A D Poyser, Calton.
- Pearson, A. M. 1962. Activity patterns, energy metabolism, and growth rate of the voles Clethrionomys rufocanus and C. glareolus in Finland. *Ann. Zool. Soc. "Vanamo"* 24:1-58.
- Pullianen, E. 1978. Influence of heavy snowfall in June 1977 on the life of birds in NE Finnish Forest Lapland. *Aquilo, Ser. Zool.* 18:1-14.
- and Loisa, K. 1977. Breeding biology and food of the Great Grey Owl, Strix nebulosa, in north-eastern Finnish Forest Lapland. *Aquilo, Ser. Zool.* 17:23-33.
- Pyke, G. H., Pulliam, H. R. and Charnov, E. L. 1977. Optimal foraging: a selective review of theory and test. *Quart. Rev. Biol.* 52:137-154.
- Ritchie, R. J. 1980. Food caching behaviour of nesting wild hawk owls. *Raptor Res.* 14:59-60.
- Thönen, W. 1965. Tannenhäher plündern Beutevorräte des Sperlingkauzes. *Ornithol. Beobachter* 62:196-197.

This paper constitutes Report No. 170 from the Värriö Subarctic Research Station of the University of Helsinki.

Sexual Size Dimorphism and Life-History Traits of Tengmalm's Owl: A Review¹

Erkki Korpimäki²

Abstract.--The ecology of Tengmalm's Owl was studied for 21 years in western Finland. At the beginning of the nestling period, females are on average 43 % heavier than males, but their wings are only 5 % longer than those of males. The degree of sexual dimorphism in weight is higher than that of other European owls. Large females have more striking force and catch more voles, whereas small males can also take more agile prey, such as birds. Because of sexual size dimorphism, scarcity of nest-holes and vole cycles, a majority of males is resident but females nomadic in western Finland. Thus, local population fluctuations of females seem to be more pronounced than those of males. Females usually enter the breeding population as yearlings, whereas males only when they are 2-year-old. These intersexual differences in life-history traits suggest that females may be more r-selected than males.

INTRODUCTION

The ecology of Tengmalm's Owl (Boreal Owl in North America) *Aegolius funereus* was studied during 1966-86 in South Ostrobothnia (63°N, 23°E), western Finland. Methods were described in other papers (e.g. Korpimäki 1981, 1983, 1984, 1985a, 1986a, 1987a, b). This paper gives a review of results and also summarizes some other European studies on this species. The main purpose is to compare the life-history traits of female and male Tengmalm's Owls, because the sexes show size dimorphism, with females being markedly larger than males.

¹Paper presented at the symposium, Biology and Conservation of Northern Forest Owls, Feb. 3-7, 1987, Winnipeg, Manitoba. USDA Forest Service General Technical Report RM-142.

²Erkki Korpimäki is Research Worker of Academy of Finland at Department of Zoology, University of Oulu, Oulu, Finland. Present address: kp. 4, SF-62200 Kauhava, Finland.

DIVISION OF DUTIES BETWEEN SEXES

Both the incubation and nestling period of Tengmalm's Owl take approx. 30 days (Korpimäki 1981), and thereafter fledglings are fed by mates for at least three weeks (März 1968). As other birds of prey, male and female divide duties in the breeding season. The male provides nearly all food for the whole family from before the egg-laying until the young are three weeks old, but he does not take part in incubating the eggs or brooding the young (Korpimäki 1981).

The female stays in nest-hole from one week before the start of egg-laying until the young are three weeks old, and is entirely fed by the male. So she is responsible for producing and incubating the eggs and for brooding the young. At the end of the nestling period, she takes part in feeding, but only at a low rate (Korpimäki 1981).

SEXUAL SIZE DIMORPHISM

At the beginning of the nestling period, female Tengmalm's Owls are on average 43 % heavier than males, but their wings are only 5 % longer than those of

males (Korpimäki 1986b). The degree of sexual dimorphism in weight is higher than that of other European owls (Lundberg 1986).

Until now, no fewer than at least 20 hypotheses have been advanced to explain the reversed sexual size dimorphism in birds of prey. Lundberg (1986), after analysing size dimorphism in European owls, suggested, that female owls are larger than males in order to reduce the effects of temporary food shortage during the breeding period. This "starvation hypothesis" yields at least six predictions (Korpimäki 1986b, Lundberg 1986): (1) northern species should be more dimorphic in weight than southern ones, (2) earlier breeding species at a given latitude should be more dimorphic, (3) female size and (4) the degree of dimorphism should increase with food unpredictability at breeding, (5) pairs laying early in the season, under unpredictable weather and food conditions, should be more dimorphic, and (6) have larger females, than those laying later, when environmental conditions are more constant.

Lundberg (1986) showed that the prediction 1 was true in European owls. In western Finland, early-breeding species in two communities of vole-eating birds of prey were more dimorphic in weight than late-breeding ones, with Tengmalm's Owl being the earliest-breeding and most weight dimorphic species (Korpimäki 1986b). This is consistent with the prediction 2. The degree of weight dimorphism between mates within pairs of Tengmalm's Owl correlated negatively with the timing of egg-laying, while the wing length of males correlated positively with the laying date of their partners. Clutch size and number of fledglings produced decreased with the degree of weight dimorphism within owl pairs (Korpimäki 1986b). These results are in agreement with the predictions 5 and 6.

Because of clear division of duties in the breeding season, different selective factors act on females and males. It seems that the large size of female Tengmalm's Owls has evolved in order to increase their fasting endurance. Food items are delivered to the female by the male at long and unpredictable intervals, because breeding starts at the end of March or at the beginning of April under adverse weather conditions. At that time, usually occurring snowfalls decrease the hunting success of the male (Korpimäki 1987c). In contrast, selection acts on males to become efficient foragers. Aerial agility increases with decreasing wing length (Andersson and Norberg 1981). Thus,

Table 1.--Number of available nest-boxes or holes, number of Tengmalm's Owl nests, percentage of nest-holes used, number of unpaired males, and number of nests in which parent owls were trapped during 1979-86 in western Finland.

Year	Number of holes	Number of nests (1)	Per cent used	Number of unpaired males (2)	Number of nests in which parent owls were trapped (3)	
					Females	Males
1979	355	37	10.4	6	31	14
1980	395	24	6.1	16	24	9
1981	395	10	2.5	18	7	6
1982	415	34	8.2	18	34	25
1983	450	27	6.0	30	25	19
1984	450	10	2.2	4	10	7
1985	450	47	10.4	11	35	36
1986	450	88	19.6	15	81	76
Tot.	3360	277	8.2	118	247	192

Note. (1) See Korpimäki (1981, 1984, 1985a, 1986a, 1987a, b) for methods used in collecting data on population fluctuations and breeding performance.

(2) In late February and March (i.e. before the breeding season) nest-sites occupied by male Tengmalm's Owls were localized by listening to displays, using the point-stop method and playback technique (e.g. Lundberg 1978, Holmberg 1979). Later checking visits to nest-holes revealed the males, which were stayed unpaired.

(3) See Korpimäki (1981, 1983, 1987a) for trapping methods.

small males probably are more effective and economical hunters and better competitors for good territories and nest-holes (Korpimäki 1986b). In conclusion, the "starvation hypothesis" seems to explain the high degree of reversed size dimorphism in Tengmalm's Owl.

Olsen and Olsen (1984) suggested that reversed size dimorphism of birds of prey might be explained by "sexual selection" (as first outlined by Darwin 1871); namely that competition between females for the more scarce resource, the males, selects for large females. Males may be the more scarce resource, because they hold territories with good nest-site and food supply. This explanation seems to hold true for the European Sparrowhawk *Accipiter nisus* in Scotland (Newton 1986). The sex ratio of this raptor is biased in favour of females, because they are longer-lived than males. In contrast,

there is generally a surplus of males in Tengmalm's Owl populations, probably because of larger mortality of females in comparison to males (Korpimäki et al. 1987). For instance, on average 30 % of males in western Finland were unpaired during 1979-86 (table 1). The most probable reason is a lack of females, because a majority of these males occupied territories, which had earlier been suitable for breeding and where a nest-box was available. Thus, male Tengmalm's Owls may compete for the scarce resource, the females. So it seems that the high degree of sexual dimorphism of this owl cannot be explained by "sexual selection", but only further studies will show, which factors are most important.

HUNTING HABITS

Male Tengmalm's Owls have a wider prey spectrum than females; females catch more voles, whereas males take more birds (Korpimäki 1987d). These differences may be caused by the following factors. (1) Small, nimble males are better adapted to catch birds, which are very agile prey. (2) Large females have more striking force and are therefore better suited for hunting relatively large voles, such as *Microtus* spp. in Fennoscandia. (3) Agile males may more often hunt in forest and "clumsy" females in open ground. (4) Females have smaller wing-load in relation to their body weight than males; so they may more often perch when hunting, whereas males may more often quarter. Perching is more suitable for catching small mammals and quartering for capturing birds. However, these explanations are only suggestions, because there are no data on possible differences in prey preference, and hunting habitats or habits between female and male Tengmalm's Owls. The former should be studied experimentally in captivity and the latter by radio-tracking in autumn or winter, when both sexes hunt only for themselves.

WINTERING STRATEGIES

Tengmalm's Owl is a hole-nester, which suffers from a scarcity of nest-sites at least in Fennoscandian coniferous forests (von Haartman 1968, Lundberg 1979). Site-tenacious owls benefit by familiarity with local food resources, refuges from predators and nest-sites (Hinde 1956, Korpimäki 1987a). Both a scarcity of nest-sites and familiarity with territories favour residency.

Tengmalm's Owl uses small rodents, mainly voles, as its staple food. The most important alternative prey groups are

shrews and birds (Sulkava and Sulkava 1971, Korpimäki 1981, 1986c). Vole populations are relatively stable in central Europe, but show 3-5-year cycles in Fennoscandia, with most pronounced fluctuations in the north and least pronounced in the south (Hansson and Henttonen 1985). However, abundances of voles in various areas fluctuate asynchronously (e.g. Myllymäki et al. 1977); so this cyclical food production favours adult nomadism (Andersson 1980). Because of its small body size, Tengmalm's Owl cannot hunt effectively small rodents protected by deep snow layer (Korpimäki 1987d). In general, the persistence and depth of snow cover increase northwards in Fennoscandia, although the snow layer in southern and western Finland is much shallower than at the same latitudes in eastern Finland and Sweden. Thus, it would be adaptive for Tengmalm's Owls to overwinter in areas of shallow snow cover.

The above-mentioned opposite selective pressures result in differences in breeding dispersal (*sensu* Greenwood and Harvey 1982) between the sexes: (1) Probably all males and a majority of females are resident in central Europe, (2) a majority of males is resident but a majority of females nomadic in the transition zone (e.g. in southern and western Finland), and (3) many males are also nomadic in northern Fennoscandia (Korpimäki 1986a, Löfgren et al. 1986). According to Korpimäki et al. (1987), the similar intersexual differences are also evident in the natal dispersal (*sensu* Greenwood and Harvey 1982).

The resident habit of male has been suggested to have evolved to ensure access to nest-holes, which are in short supply (Lundberg 1979). Thus, males must guard their nest-holes against competitors also outside the breeding season. Agile males are better able to hunt alternative prey and in forest than "clumsy" females. The availability of small mammals and birds in winter is better in forests than in open ground (Korpimäki 1986c). Because the male is responsible for food provision in the breeding season, he benefits by the detailed knowledge of the territory. Resident males can better compete for a scarce resource, females, and thus their partners lay earlier and larger clutches than those of immigrant males (Korpimäki 1987a). These factors may further favour the residency of males.

Females are more specialized to prey on small rodents than are males, and thus they willingly overwinter in areas of high abundance of voles and shallow snow cover. They benefit by familiarity with the territory only during a short time period

at the end of the nestling period. These reasons may explain, why females are nomadic.

LIFE-HISTORY TRAITS OF FEMALES AND MALES

The life-history of any species is made up of a complex of adaptive traits (Stearns 1976, 1977), but there may also be intraspecific differences in life-history traits (Stearns 1980). The model of r- and K-selection is often used to explain life-history phenomena, although its importance for our understanding of life-history evolution has generated also some controversy in recent years (Boyce 1984).

Stearns (1976) summarized the environmental and organismic correlates of r- and K-selection. r-selection is characterized by, e.g. a variable population size in time, early reproduction and short lifespan. In contrast, K-selection is outlined by, e.g. a constant population size in time, delayed reproduction, keen competition and long lifespan.

Table 2.--Number (N) and percentage (%) of female and male Tengmalm's Owls belonging to the three age classes when making their first breeding attempt within the study area in western Finland. Pooled data from 1985-86.

Age class	Females		Males	
	N	%	N	%
1 yr	53	53.0	17	22.4
2 yr	22	22.0	39	51.3
+2 yr	25	25.0	20	26.3
Total	100	100.0	76	100.0

Note. (1) From 1981 onwards at least 60 % and from 1982 onwards at least 70 % of breeding females and males were trapped and ringed (see table 1). All fledglings in known nests were ringed during 1973-86. So one could identify which owls were recruits in the breeding population.

(2) First-year and second-year owls were differentiated from older ones by checking the moult score of primaries according to Glutz von Blotzheim and Bauer (1980). The reliability of this method was confirmed by 27 retrapped known-age owls (E. Korpimäki unpubl.).

Suggesting that there are no non-breeding females in the population, the number of females varied between 10 and 88

(mean 34.6 ± 25.0) and the number of males between 14 and 94 (mean 47.6 ± 23.6) during 1979-86 in South Ostrobothnia (table 1). The coefficient of variation ($CV = 100 \times S.D. / \text{mean}$) for females (72 %) is markedly larger than that for males (50 %). Thus, the number of males seems to be more constant than that of females, but only further studies will show, whether the population also includes some non-breeding females.

Assuming that the probability of the first breeding attempt occurring within the study area is similar for both sexes, females start to reproduce as significantly younger than do males (Mann-Whitney U-test, two-tailed; $U = 4696.5$, $P < 0.01$; table 2). Females usually enter the breeding population as yearlings, whereas males only when they are 2-year-old. Males compete for females, and territories with good nest-hole and food supply, but females can usually make a choice between several males and territories, because there are many unpaired males in the population (table 1). This biased sex ratio in favour of males is probably caused by the higher mortality of females during irruptions (Korpimäki et al. 1987) and by Pine Martens *Martes martes*, which sometimes kill females in their nest-holes (e.g. Korpimäki 1981, Sonerud 1985). Thus, males seem to be longer-lived than females.

In conclusion, the present results suggest that there are marked differences in the life-history traits of female and male Tengmalm's Owls; females seem to be more r-selected than males. This coincides with the r-selected nature of females' main prey (i.e. voles) and allows the breeding population to respond rapidly to the population fluctuations of voles, because of immigration of females to good vole areas (Korpimäki 1985b).

ACKNOWLEDGMENTS

My field studies on Tengmalm's Owl were partly financed by the Finnish Cultural Foundation, the Oulu Student Foundation, the Jenny and Antti Wihuri Foundation, the Emil Aaltonen Foundation and the Academy of Finland. I wish also to thank Assoc. Prof. Seppo Sulkava for valuable comments on the manuscript.

LITERATURE CITED

- Andersson, M. 1980. Nomadism and site tenacity as alternative reproductive tactics in birds. *J. Anim. Ecol.* 49: 175-184.
 Andersson, M. and Norberg, R. A. 1981. Evolution of reversed sexual size

- dimorphism and role partitioning among predatory birds, with a size scaling of flight performance. *Biol. Journ. Linn. Soc.* 15: 105-130.
- Boyce, M. S. 1984. Restitution of r- and K-selection as a model of density-dependent natural selection. *Ann. Rev. Ecol. Syst.* 15: 427-447.
- Darwin, C. 1871. *The descent of man and selection in relation to sex.* Murray, London.
- Glutz von Blotzheim, U. N. and Bauer, K. M. 1980. *Handbuch der Vögel Mitteleuropas.* Vol. 9. Akademische Verlagsgesellschaft, Wiesbaden.
- Greenwood, P. J. and Harvey, P. H. 1982. The natal and breeding dispersal in birds. *Ann. Rev. Ecol. Syst.* 13: 1-21.
- von Haartman, L. 1968. The evolution of resident versus migratory habit in birds. Some considerations. *Ornis Fenn.* 45: 1-7.
- Hansson, L. and Henttonen, H. 1985. Gradients in density variations of small rodents: the importance of latitude and snow cover. *Oecologia (Berlin)* 67: 394-402.
- Hinde, R. A. 1956. The biological significance of the territories of birds. *Ibis* 98: 340-369.
- Holmberg, T. 1979. Point transect census of Tengmalm's Owl - a methodological study. *Vår Fågelvärld* 38: 237-244.
- Korpimäki, E. 1981. On the ecology and biology of Tengmalm's Owl (*Aegolius funereus*) in Southern Ostrobothnia and Suomenselkä, western Finland. *Acta Univ. Oul. A* 118. *Biol.* 13: 1-84.
- Korpimäki, E. 1983. Polygamy in Tengmalm's Owl *Aegolius funereus*. *Ornis Fenn.* 60: 86-87.
- Korpimäki, E. 1984. Clutch size and breeding success of Tengmalm's Owl *Aegolius funereus* in natural cavities and nest-boxes. *Ornis Fenn.* 61: 80-83.
- Korpimäki, E. 1985a. Clutch size and breeding success in relation to nest-box size in Tengmalm's Owl *Aegolius funereus*. *Holarctic Ecol.* 8: 175-180.
- Korpimäki, E. 1985b. Rapid tracking of microtine populations by their avian predators: possible evidence for stabilizing predation. *Oikos* 45: 281-284.
- Korpimäki, E. 1986a. Gradients in population fluctuations of Tengmalm's Owl *Aegolius funereus* in Europe. *Oecologia (Berlin)* 69: 195-201.
- Korpimäki, E. 1986b. Reversed size dimorphism in birds of prey, especially in Tengmalm's Owl *Aegolius funereus*: a test of the "starvation hypothesis". *Ornis Scand.* 17: 309-315.
- Korpimäki, E. 1986c. Seasonal changes in the food of the Tengmalm's owl *Aegolius funereus* in western Finland. *Ann. Zool. Fennici* 23: 339-344.
- Korpimäki, E. 1987a. Selection for nest-hole shift and tactics of breeding dispersal in Tengmalm's Owl *Aegolius funereus*. *J. Anim. Ecol.* 56: 185-196.
- Korpimäki, E. 1987b. Timing of breeding of Tengmalm's Owl *Aegolius funereus* in relation to vole dynamics in western Finland. *Ibis* 129: 58-68.
- Korpimäki, E. 1987c. Prey caching of breeding Tengmalm's Owls *Aegolius funereus* as a buffer against temporary food shortage. *Ibis* 129 (in press).
- Korpimäki, E. 1987d. Wintering strategies of Tengmalm's Owl *Aegolius funereus*. *Aquilo Ser. Zool.* (in press).
- Korpimäki, E., Lagerström, M. and Saurola, P. 1987. Field evidence for nomadism in Tengmalm's Owl *Aegolius funereus*. *Ornis Scand.* 18 (in press).
- Lundberg, A. 1978. Census methods for the ural owl *Strix uralensis* and the Tengmalm's owl *Aegolius funereus*. *Anser Suppl.* 3: 171-175.
- Lundberg, A. 1979. Residency, migration and a compromise: adaptations to nest-site scarcity and food specialization in three Fennoscandian owl species. *Oecologia (Berlin)* 41: 273-281.
- Lundberg, A. 1986. Adaptive advantages of reversed sexual size dimorphism in European owls. *Ornis Scand.* 17: 133-140.
- Löfgren, O., Hörnfeldt, B. and Carlsson, B. G. 1986. Site tenacity and nomadism in Tengmalm's Owl (*Aegolius funereus* (L.)) in relation to cyclic food production. *Oecologia (Berlin)* 69: 321-326.
- Myllymäki, A., Christianssen, E. and Hansson, L. 1977. Five year surveillance of small mammal abundance in Scandinavia. *Eppo Bull.* 7: 385-396.
- März, R. 1968. *Der Rauhfußkauz.* Die neue Brehm-Bücherei, Wittenberg Lutherstadt.
- Newton, I. 1986. *The Sparrowhawk.* T. & A. D. Poyser, Calton.
- Olsen, P. and Olsen, J. 1984. Book review. *The Falcons of the World.* *Aust. Wildl. Res.* 11: 205-206.
- Sonerud, G. A. 1985. Nest hole shift in Tengmalm's Owl *Aegolius funereus* as defence against nest predation involving long-term memory in the predator. *J. Anim. Ecol.* 54: 179-192.
- Stearns, S. C. 1976. Life-history tactics: a review of the ideas. *Quart. Rev. Biol.* 51: 2-47.
- Stearns, S. C. 1977. The evolution of life history traits: a critique of the theory and a review of the data. *Ann. Rev. Ecol. Syst.* 8: 145-171.
- Stearns, S. C. 1980. A new view of life-history evolution. *Oikos* 35: 266-281.
- Sulkava, P. and Sulkava, S. 1971. Die nistzeitliche Nahrung des Rauhfußkauzes *Aegolius funereus* in Finnland 1958-67. *Ornis Fenn.* 48: 117-124.

Annual, Seasonal, and Nightly Variation in Calling Activity of Boreal and Northern Saw-Whet Owls¹

David A. Palmer²

Abstract.-- Calling activity of Boreal and Northern Saw-whet Owls was monitored over a 6-year (1980-1985) period in north-central Colorado. Intensive surveys were completed in 1983 and 1984 to determine nightly variations in calling intensity and to assess the influence of environmental conditions on calling activity. Calling activity of both species fluctuated considerably over the 6-year period and appeared to be associated with changes in owl prey populations. Both species reached peak calling activity in 1984 when 14 saw-whet and 27 boreal owls were heard. Overall length of the courtship period ranged from 31 to 119 days (avg. = 63) for boreal owls and from 70 to 93 days (avg. = 81.5) for saw-whet owls. Calling activity of boreal owls was slightly influenced by wind, precipitation and moon phase while cloud cover and temperature had no apparent effect. Saw-whet owl calling activity was influenced by wind and slightly by moon phase.

INTRODUCTION

Both the Boreal Owl (*Aegolius funereus richardsonii*) and the Northern Saw-whet Owl (*A. acadicus*) are small, nocturnal owls which have wide distributions in the northern regions of North America (Burton 1977, AOU 1983). Because of their small size, secretive habits and generally northern range, the owls' biologies are poorly understood, especially regarding habitat requirements and breeding biology. Although generally secretive, both species are extremely vocal during the early breeding season and can be located with relatively little effort using nocturnal surveys (Holmberg 1979, Webb 1982). Kuhk (1953) considered Tengmalm's owl (*A. f. funereus*), one of the European subspecies of the boreal owl, to be one of the most persistent singers among European owls and found the males easy to locate for a brief period in the spring. Information on calling activity of boreal owls in North America is limited to the behavioral significance of vocalizations (Bondrup-Nielsen 1978, 1984, Meehan 1980) while little is known about any facet of saw-whet owl calling activity.

Nocturnal surveys have been used to estimate Tengmalm's owl populations in Europe (Lundberg 1978, Holmberg 1979) and recently to locate breeding boreal owls well south of their previously recognized breeding range (Eckert and Savaloja 1979, Hayward and Garton 1983, Palmer and Ryder 1984). Webb (1982) used nocturnal surveys to determine the populations status of five species of montane owls, including boreal and saw-whet owls in the Colorado mountains. Nocturnal surveys can be utilized to determine habitat preferences, population densities and fluctuations, and to aid in nest location. Nocturnal surveys, utilizing both road counts of calling owls and elicitation of owl calls using playback recordings, have been used extensively to determine the status of several owl species in North America (Call 1978, Fuller and Mosher 1981, Johnson et al. 1981). In this study, boreal and saw-whet owl calling activity was monitored over a 6-year period (1980-85) in northern Colorado to determine how calling activity fluctuates on an annual, seasonal and nightly basis. Additionally, information was collected to determine how various environmental conditions influence the calling activity of both owl species.

STUDY AREA AND METHODS

The study area, located in western Larimer and eastern Jackson counties in north-central Colorado, ranged in elevation from 2370 to 3300 m. The higher elevation areas were covered by spruce-fir (*Picea engelmannii*-*Abies lasiocarpa*) and

¹Paper presented at the symposium, Biology and Conservation of Northern Forest Owls, Feb. 3-7, 1987, Winnipeg, Manitoba. USDA Forest Service General Technical Report RM-142.

²David A. Palmer is a Wildlife Biologist at Wildlife International Ltd., Easton, Md.

lodgepole pine (*Pinus contorta*) forests while Douglas fir (*Pseudotsuga menziesii*) and ponderosa pine (*Pinus ponderosa*) forests predominated at lower elevations. Trembling aspen (*Populus tremuloides*) was common in riparian areas at lower elevations.

Both species of owls have a wide repertoire of vocalizations (Johnson et al. 1979, Karalus and Eckert 1979, Bondrup-Nielsen 1984) but only the primary, or mate attraction, calls were used for the purposes of this investigation. Male boreal owls render the primary vocalization from late winter until pair formation or until the season has progressed past the point where nesting is feasible (Bondrup-Nielsen 1984) while male saw-whet owls call more softly and less frequently after pair formation (pers. obs.). Both species call occasionally in the fall (Kuhk 1953, pers. obs.).

Owl calling activity was monitored using a modification of the aural census method described by Holmberg (1979). While driving, I stopped and listened for vocalizations for 5 to 10 minutes every 0.7 km along 57 km of roads within the study area. Nocturnal surveys were conducted at least once every 2 weeks from April through June 1980 and January through June 1981-1985. Tape recordings of the species' primary vocalizations were used in 1981, 1982 and 1985 to elicit calls.

Intensive surveying was done in 1983 and 1984 during which time surveys were conducted almost every night. During this period, censuses were started at dusk and usually ended by 0200. Early morning censuses, begun at 0200 and ending at dawn, were conducted periodically throughout the study period. Starting locations were alternated on a nightly basis so that all areas were sampled at different times of the night. Approximately 75% of the study area was composed of habitat occupied primarily by boreal owls while 25% was occupied by saw-whet owl habitat so that the amount of time spent censusing boreal owls was more than that spent on saw-whet owls. Censuses were not conducted on nights with extremely heavy snowfall or high winds. Each time an owl was heard during this period (1983-84) I recorded the following variables: temperature; wind speed (Beaufort scale) and direction; degree of precipitation (0-3); percent cloud cover (0-4); the phase of the moon (new, 1/4, 1/2, 3/4, and full) and degree of illumination (0-4), from no moon, or a moon completely occluded by clouds, to a full moon with a clear sky. Tape recordings were used occasionally to try to capture the owls but were not used to elicit calling.

RESULTS AND DISCUSSION

The primary emphasis from 1980-82 was placed on locating boreal owls only; and only a portion of lower elevation habitat types, where saw-whet owls were most numerous, was sampled during this period. Census routes were completed 130 times in habitat types occupied by boreal owls and 94 times

Table 1. -- Results of aural censuses for boreal and saw-whet owls from 1980 to 1985 in Larimer and Jackson counties, Colorado.

Year	# census	#boreal	Owl species		
			#/hr	#saw-whet	#/hr
1980	10	5	0.50	*	
1981	10	8	0.42	3	0.50
1982	11	3	0.27	0	0.00
1983	44	9	0.15	2	0.11
1984	45	27	1.13	14	1.43
1985	10	0	0.00	1	0.10

*no attempts were made to locate saw-whet owls in 1980.

in habitats where saw-whet owls were found, from April 1980 to June 1985 (table 1). At least one boreal owl was heard on 64 censuses (49%) while saw-whet owls were heard less frequently (30 censuses or 32%). Saw-whet owls were heard at elevations ranging from 2370 to 2700 m in primarily deciduous riparian areas while all boreal owls were located in coniferous forests above 2770 m. Because of the amount of variation in censusing effort from year to year, all owl numbers are presented as both total numbers and owls per hour of census.

Annual Variation

Fifty-two boreal and 18 saw-whet owls were heard calling during the period. The number of boreals ranged from 0 (0/hr) in 1985 to 27 (1.13/hr) in 1984, while numbers of saw-whets ranged from 0 (0/hr) in 1982 to 14 (1.43/hr) in 1984 (table 1). A high degree of annual variation in the number of individual owls found calling has been widely reported for boreal and Tengmalm's owls and is usually associated with fluctuations in small mammal populations (Lundin 1961, Lundberg 1978, 1979, Bondrup-Nielsen 1978, Korpimaki 1981, 1985). In years when small mammal populations are depressed, owls may be present but choose not to call because of the unlikely chance of breeding successfully (Lundberg 1979).

Small mammal trapping on the study area from 1983 to 1985 revealed that red-backed voles (*Clethrionomys gapperi*) and *Microtus* spp., the boreal owl's principal prey on the study area, increased significantly from 1983 to 1984 and then decreased in 1985 (table 2). Deer mice (*Peromyscus maniculatus*) decreased from 1983 to 1984 and again in 1985. Boreal and saw-whet owl calling activity was correlated with population trends of *Clethrionomys* and *Microtus* but not with *Peromyscus* (table 2). A longer term study with a greater sample size is needed to verify this trend but it does agree with what has been found by other investigators.

Table 2.--Results of small mammal trapping during the three years that intensive owl surveys were conducted.

Year	Small mammal capture rates (#/100 trap nights)			Total
	Deer Mouse	Red-backed Vole	Microtus spp.	
1983	2.5	0.4	0.2	3.1
1984	1.8	1.2	0.5	3.5
1985	0.0	0.0	0.0	0.0

Seasonal Variation

The earliest date that boreal owls were heard during the breeding season (January-June) was on 18 February 1984 and the latest was on 21 June 1984 while the earliest and latest dates that saw-whets were heard calling were 29 January and 30 April 1983. The onset of calling for the season was latest for both species in 1981 when boreal owls were first heard on 18 April and saw-whet owls were first heard on 23 April (fig. 1). While saw-whet owl calling had ceased by late April, boreal owls had a lull period in early May followed by an increase in activity in late May-early June (fig. 2). This same pattern was observed for Tengmalm's owls by Kuhk (1953) and Schelper (1972) in West Germany and can probably be attributed to increased activity by males nesting for the first time (Kuhk 1953) or by unpaired males just before

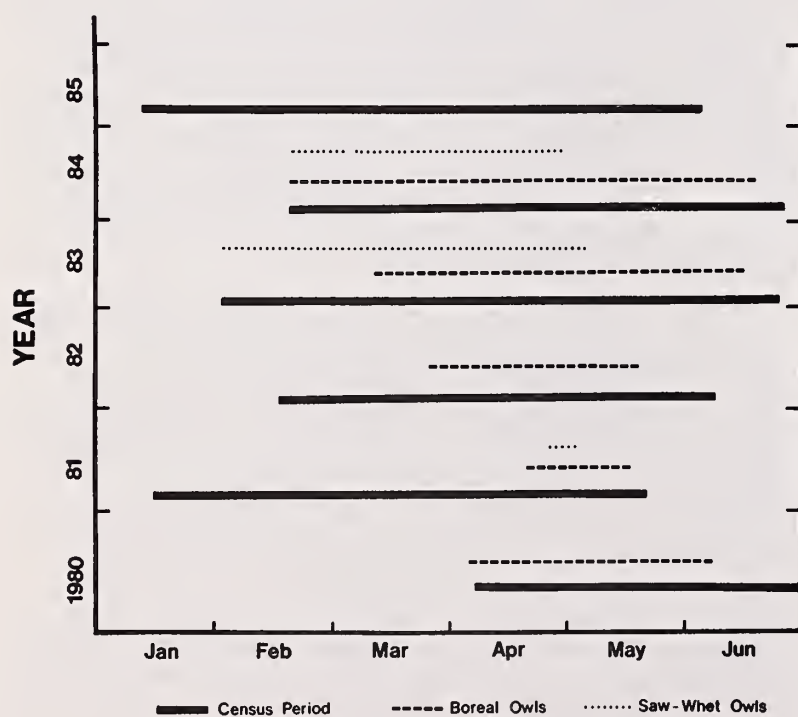

Fig. 1. Duration of the courtship periods of boreal and saw-whet owls, 1980-85, in north-central Colorado.

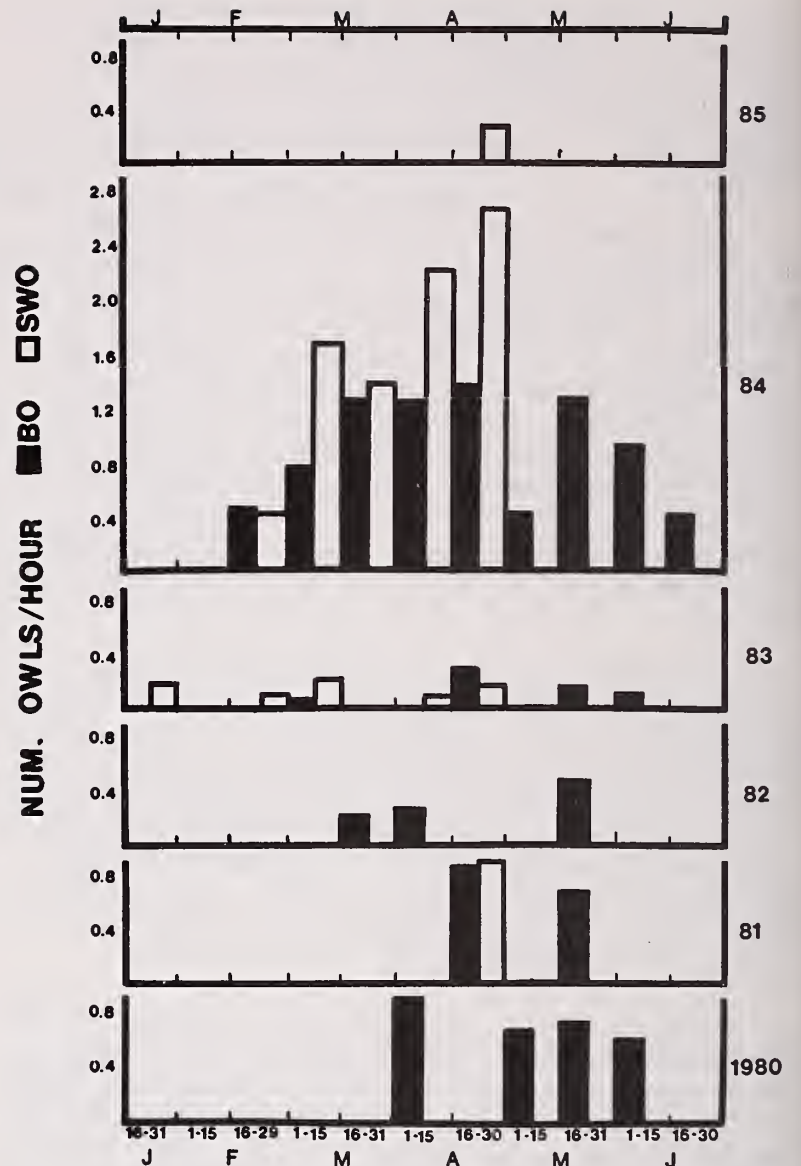

Fig. 2. Distribution of the calling activity of boreal and saw-whet owls during the spring, 1980-85, in north-central Colorado.

they stop calling for the season (Bondrup-Nielsen 1978). Kuhk (1953), Kallander (1959), and Lundin (1961) all report that Tengmalm's owls can be heard in every month of the year except July. I heard no calling in the fall for either species but it has been reported for my Colorado study area (Reddall 1985).

Both the onset of calling and the peak calling period (usually late April) that I found are slightly later than reported for saw-whet owls (Farbotnik 1977-78, Karalus and Eckert 1979). Kuhk (1953), Kallander (1959), Bondrup-Nielsen (1978) and Meehan (1980) all report boreal (Tengmalm's) owl peak calling in late March or early April, about three weeks earlier than the peak that I observed. Holmberg (1979) found that Tengmalm's owl calling activity began earlier and was more frequent in years of high prey populations, possibly explaining the earlier calling dates that I observed in 1984.

Korpimaki (1981) stated that day length is the primary factor regulating the timing of Teng-

malm's owl breeding in moderate climates, while temperature and food have lesser effects. All of the previous studies of boreal (Tengmalm's) owls mentioned were located at between 55 and 65 degrees north latitude where day length in late March-early April, (approximately 14 h), when peak boreal owl calling occurs, is approximately the same as day length in my study area (40° N) in late April, the period when I found peak calling activity. It appears that day length may regulate breeding in Colorado as well.

According to Bondrup-Nielsen (1978) the courtship period for boreal owls ended at about the same time that the nightly minimum temperature remained above 0 C and the snow was gone from the ground. These conditions were not met on my study area until early summer, precluding these as factors in the timing of the breeding season on my study area. Nightly minimum temperatures when the courtship period ended during my investigation usually ranged between -10 and -5 C. Korpimaki (1981) stated that egg laying can occur with temperatures as low as -20 C if sufficient prey are available to maintain the incubating female's body temperature. Snow depth reached its maximum at about the same time that boreal owl courtship period was at its peak (table 3), indicating that snow depth probably does not play a role in the timing of the breeding season in the high elevations of the Rocky Mountains. Saw-whet owls were found calling at lower elevations where snowfall was less and temperatures were higher, more approximating other areas where they are found breeding, and the timing of their breeding corresponds with breeding in other areas (Santee and Granfield 1939, Johns and Johns 1978, Follen 1981, Norton and Holt 1981).

The duration of the boreal owl courtship period (all owls) ranged from 31 days in 1981 to 119 days in 1984 while saw-whet courtship lasted from 70 to 93 days, excluding 1981 when little effort was expended locating saw-whet owls and they were heard for a period of only five days (fig. 1). Average courtship period for individual boreal owls, excluding those owls heard on only one occasion, ranged from 18.6 days in 1983 to 49.3 days in 1984. The longest courtship period for an individual boreal owl lasted 102 days for

Table 3.--Snow depth (cm) at the time courtship began and ended for boreal and saw-whet owls from 1980-1985 in northern Colorado.

Year	boreal owl		saw-whet owl	
	first	last	first	last
1980	213	117	-	-
1981	140	61	56	56
1982	180	214	-	-
1983	147	122	11	0
1984	175	122	0	0
1985	-	-	-	-

an owl that was apparently unpaired. Saw-whet owls, while not heard in two of the six years (1980 and 1982) and heard only briefly in two others (5 days in 1981 and 1 day in 1985), had approximately the same length courtship period as boreal owls in the two years that they were heard regularly. The longest courtship period of an individual saw-whet was 93 days and it nested successfully.

Bondrup-Nielsen (1978) found average boreal owl courtship periods ranging from 8.2 to 10.2 days while overall courtship length lasted from 28 to 55 days, shorter than the courtship periods that I found. Meehan (1980) found that mated boreal owls have longer courtship periods (aver 37.8, days, range 20-51 days) than those that failed to attract mates (range 6-35 days). I was only able to locate four nests during my study and the courtship periods of these successful males ranged from 4 to 59 days (aver. 26). Throughout my study, however, the owls that had the longest courtship periods were found to be unsuccessful males which sang well into June.

I could find only one reference to the length of a saw-whet courtship period and this was approximately 25 days (Farbotnik 1977-78). Less is known about the the saw-whet owl primary call and references made to calling owls in the literature could include a variety of different calls, therefore the duration of the courtship period is difficult to ascertain from the accounts given.

Singing Activity Through the Night

The majority of censuses were conducted between dusk and 0200 with only infrequent surveys from 0200 to dawn. Both species generally began calling within one hour after sunset and sang throughout the census period. Saw-whet owls were heard calling during the early morning censuses more frequently than boreals and they were heard calling in the predawn hours throughout the study period, whereas boreal owls were heard calling in the morning only in the latter half of the study period. Marz (1968) reported that Tengmalm's owls often call for a time after dusk, become silent until midnight, then resume calling until early morning. Meehan (1980) found that boreal owls begin calling after dusk and end by midnight, with few exceptions. I found that once the owls began calling in the evening, for either species, it generally continued until well after midnight with no detectable decrease in intensity.

The Influence Of Environmental Factors On Calling Activity

Several environmental factors which may influence the calling activity of boreal and saw-whet owls were investigated. Because of the relatively few contacts of both species in 1983, I used only data gathered in 1984, when significantly more owls were heard. Analysis of the effects of weather is particularly difficult because

weather variables are often intercorrelated and also correlate with the time of year, habitat and time of night. Armstrong (1963) states that extreme weather conditions tend to inhibit calling, especially early in the courtship period, but as the season progresses birds are less affected. Therefore, owls calling latest in the season may be less likely to be influenced by weather conditions than those that are heard early in the season. In this paper I have treated each environmental variable independently although a combination of factors could have resulted in changes in calling activity of the owls.

Temperature

Low temperatures seemed to have little influence on calling activity of either species once the breeding season began. Boreal owls were heard calling when temperatures were as low as -18 C and saw-whets were heard when it was as low as -14 C. Boreal owls were heard most often when temperatures were between -10 and -5 C and saw-whets were heard calling most often at -5 to 0 C (table 4a). Temperatures rarely fell below -15 C in the lower elevations of the study area, so it could not be determined if extremely low temperature effected calling activity of saw-whet owls. The coldest temperature recorded during a census period was 25 C but there were high winds at the time and, although no owls were heard, this could have been due to the winds rather than the cold temperatures. Mikkola (1983) stated that cold temperatures, in combination with high winds, brought a pronounced reduction in calling of tawny owls (*Strix aluco*). Bondrup-Nielsen (1978) found that cold temperatures significantly reduced the calling rate of boreal owls but they were still heard calling in temperatures as low as -25 C. Mikkola (1973) found that most Tengmalm's owls were heard calling at temperatures between -10 and 0 C.

Precipitation

Snowfall (no rain was recorded during the study period), most of which was light, occurred at some time during 43% of the censuses that were conducted (table 4b). However, a majority of both species (75% boreal, 81% saw-whet) were heard calling when there was no snow falling. On only five occasions (2.8%) were boreal owls heard calling in heavy snow and saw-whets were never heard when there was heavy snowfall. Snowfall significantly reduced the activity of boreal owls (G test, $P < .05$) (Sokal and Rohlf 1969) whereas saw-whet owls were not significantly effected ($P > .05$) mainly because the lower elevations rarely received more than moderate snowfall (table 4b). Lundin (1961), Bondrup-Nielsen (1978), Holmberg (1979) and Korpimaki (1981) all found that boreal (Tengmalm's) owls call more frequently when there is no precipitation.

Table 4.--Frequency of boreal and saw-whet owls heard during different degrees of four environmental variables in 1984 in northern Colorado. G-test for goodness of fit was used to determine significant differences (Sokal and Rohlf 1969). BO-boreal, SW-saw-whet

		Temperature (% of occurrences)							
4a		<-20	-15	-10	-5	0	5	10	20
BO		0	5	15	34	32	9	5	0
SW		0	0	5	8	53	34	0	0

		Degree of precipitation % observed (%expected)				
4b		none	light	moderate	heavy	G-test
BO		75 (67)	16 (22)	7 (5)	3 (5)	$P < .05$
SW		81 (76)	16 (20)	3 (2)	0 (2)	$P > .05$

		% cloud cover -% observed (% expected)				
4c		0-25	26-50	51-75	76-100	G-test
BO		57 (56)	11 (9)	5 (6)	27 (30)	$P > .05$
SW		51 (56)	6 (5)	11 (14)	30 (27)	$P > .05$

		Approximate wind velocity (Beaufort scale)				
4d		0	1-2	3-4	>4	
BO		65	21	12	2	
SW		48	28	16	8	

Cloud Cover

Cloud cover did not significantly influence either boreal or saw-whet owl calling activity (G test, $P > .05$), although both species were heard most often when there was a clear sky (table 4c). Lundin (1961) and Mikkola (1983) found that cloud cover only slightly affected Tengmalm's owl calling, whereas Bondrup-Nielsen (1978) found that it depressed boreal owl calling rates in one year but not another. Hansen (1952) found that tawny owls sang less on overcast nights and Mikkola (1983) found that eagle owls (*Bubo bubo*) called more frequently on calm cloudless nights.

Wind

Wind was the most difficult environmental factor to assess because it often obscured the

owls' calls. The boreal owl's primary call was difficult to distinguish in the wind while the saw-whet call is more distinct and could be heard more easily in windy conditions. On calm, clear nights both species could be heard from over 1 km but even moderate wind made hearing owls difficult from over 100 m. Of the 181 boreal owl contacts, 118 (65%) were when there was no wind, whereas over half (52%) of the saw-whet owls were heard in moderately windy conditions (table 4d). Lundin (1961) and Bondrup-Nielsen (1978) found that, of the parameters that they measured, wind had the greatest effect on boreal owl calling activity. Mikkola (1983) found that most (68%) Tengmalm's owls were heard in calm conditions and rarely were they heard in winds exceeding 30 km/hr.

Moonlight's influence on calling activity

Armstrong (1963) notes that some nocturnal singers are particularly stimulated by moonlight and Johnson et al. (1979) found that several species of owls, including saw-whets, were more vocal during a bright waxing moon. Contrary to this, Hansen (1952) reported that moonlight significantly reduced the calling activity of tawny owls. In this study, more individuals of both species were heard during the full moon than during any other phase (table 5), however, the difference was not statistically significant (G test $P > .05$). In the six years that censusing was done, 32% of all boreal and saw-whet owls were heard calling during a full moon, more than during any other phase. It is possible that, in years when calling activity is at a low level such as in 1981 and 1983, the owls may be stimulated by the moon but when calling activity is high, such as in 1984, the moon has less of an influence on calling. Lundin (1961) found that Tengmalm's owls often begin calling for the season during a full moon and continue calling regardless of the phase. In this study, a full moon appeared to stimulate the owls to begin calling for the the season in three of the five years that owls were heard.

OVERALL EFFECT OF ENVIRONMENTAL FACTORS ON SINGING ACTIVITY

The two factors that most affected calling activity of both species were wind and precipitation, and a combination of the two severely restricted calling activity. Konig (1968) and Mikkola (1983) suggested that approaching bad weather and low atmospheric pressure were likely to inhibit the calling of Tengmalm's owls. Generally, on my study area, bad weather was preceded by high winds which made censusing difficult and few owls were heard, but I do not know whether the wind or the approaching weather system negatively influenced the owls.

The conditions that were best suited for both listening effectiveness and calling activity of both species were a calm, clear night, -10 to 0 C, and a bright moon. Holmberg (1979 p. 243) stated that, "within certain limits, (calm, no precipitation, and temperatures not below -10 C) the weather seemed to exert little effect on the

Table 5.--The influence of the moon phase on calling activity of boreal and saw-whet owls in 1984. G-test was used to test for goodness of fit. (BO-boreal, SW-saw-whet)

	Moon phase - % of occurrences (% expected)					
	new	1/4	1/2	3/4	full	G
BO	16 (18)	24 (25)	16 (13)	20 (19)	28 (22)	>.05
SW	7 (9)	11 (16)	29 (24)	26 (26)	30 (25)	>.05

[Tengmalm's] owl's vocal activity." According to Korpimaki (1981 p. 17), the best time for hearing owls is on a "clear, quiet twilight night in late winter after a cold period." This is comparable to what I found in my study area.

MANAGEMENT APPLICATIONS

Over the six-year study period, the number of both boreal and saw-whet owls heard calling varied considerably from night to night and year to year, depending on several independent factors. True populations of both species probably stayed fairly uniform during this time but detectability was highly variable. The point transect method used in this study probably does not give accurate results for population studies, however it is valuable for determining the presence or absence of both species in the survey area. Although tape recordings were not used extensively in this study, they were found to be effective for locating saw-whet owls but not very effective for locating boreal owls.

For censuses to be used effectively, Holmberg (1979) recommended that they be conducted on at least three night in March (applied to most of Sweden). On my study area, the owls tended to call later in the year, and in order to detect owls, the censuses were most effective in April. Through most of the Rocky Mountain region in the United States, biweekly surveys conducted in March and April should be sufficient to detect populations of both boreal and saw-whet owls. A minimum of three years of censusing should be done in order to detect owl populations, as extremely low vocal activity in two consecutive years is fairly likely. To improve census efficiency, censuses should be conducted on clear, calm nights with moderate temperature (-10 to 0 C). Censuses should be timed so that at least one census is done during a full moon each month.

ACKNOWLEDGEMENTS

Financial support for this investigation was provided by the Colorado Division of Wildlife, Federal Aid to Wildlife Restoration Project W-124-R. T. Washington was instrumental in obtaining funding for the study. Additional funding was provided by the Colorado Audubon Council, Fort Collins Audubon Society and the U. S. Forest Ser-

vice. I gratefully acknowledge the aid of my two field assistants, D. DeLong and J. Jeanson. A number of people assisted with surveys throughout the study period including W. Graul, J. Craig, T. Washington, P. Hegdal, R. Ryder, T. Manley, S. Palmer, J. Sedgewick, J. Ellis, J. Richards, P. Paton and A. Alldredge. I especially thank Dr. R. Ryder for his aid throughout the course of the investigation.

LITERATURE CITED

- American Ornithologist's Union. 1983. The checklist of North American birds, 6th Edition. 877pp.
- Armstrong, E. A. 1963. A study of bird song. Oxford University Press, London. 335pp.
- Bondrup-Nielsen, S. 1978. Vocalizations, nesting and habitat preferences of the boreal owl (Aegolius funereus) in North America. M. S. Thesis, Univ. Toronto. 158pp.
- Bondrup-Nielsen, S. 1984. Vocalizations of the boreal owl (Aegolius funereus richardsonii) in North America. Canadian Field-Naturalist 98:191-197.
- Call, M. W. 1978. Nesting habitats and surveying techniques for common western raptors. U.S. Bur. Land Manage., Tech. Note TN-316, Denver, Colo.
- Eckert, K. R., and T. L. Savaloja. 1979. First documented nesting of the boreal owl south of Canada. Am. Birds 33:135-137.
- Farbotnik, S. 1977-78. A diary of the nesting of saw-whet owls in Bucks County, Penn. Cassinia 57:29-33.
- Follen, D. G. Sr. 1981. Wisconsin breeding and breeding season records of saw-whet owls. The Passenger Pigeon 43:113-116.
- Fuller, M. R., and J. A. Mosher. 1981. Methods for detecting and counting raptors: a review, p. 235-246. In C. J. Ralph and J. M. Scott (eds.). Estimating the number of terrestrial birds. Stud. Avian Biol. 6.
- Hansen, A. L. 1952. Natuglens (Strix a. aluco) dogn-og ar Arsrytyme. Dansk Orn. For. Tids. 46:158-172.
- Hayward, G. D., and E. O. Garton. 1983. First nesting records for the boreal owl (Aegolius funereus) in Idaho. Condor 85:501.
- Holmberg, T. 1979. Punktaxing av Parluggla Aegolius funereus- en Metodstudie. Var Fagelvarld 38:237-244.
- Johns, J., and S. Johns. 1978. Observations on the nesting behavior of the saw-whet owl in Alberta. Blue Jay 36:36-38.
- Johnson, R. J., L. T. Haight, and J. M. Simpson. 1979. Owl populations and species status in the south-western U. S., p. 40-59. In Schaeffer, P. P. and S. M. Ehlers (eds.). Owls of the west: their ecology and conservation. Nat. Audubon Soc. West. Educ. Center, Tiburon, Calif. 97pp.
- Johnson, R. J., B. T. Brown, L. T. Haight, and J. M. Simpson. 1981. Playback recordings as a special avian census technique, p. 68-75. In C. J. Ralph and J. M. Scott (eds.). Estimating the number of terrestrial birds. Stud. Avian Biol. 6.
- Kallander, H. 1959. Photographic studies of some less familiar birds. 93. Tengmalm's owl. Brit. Birds 52:12-15.
- Karalus, K. E., and A. W. Eckert. 1974. The owls of North America. Doubleday and Co., Inc., New York. 278 pp.
- Konig, C. 1968. Lautausserungen von Rauhfusskauz (Aegolius funereus) und Sperlingskauz (Glaucidium passerinum). Vogelwelt, Beiheft 1:115-138.
- Korpimaki, E. 1981. On the ecology and biology of Tengmalm's owl (Aegolius funereus) in Southern Ostrobothnia and Suomenselka, Western Finland. Acta. Univ. Ouluensis (A) 118:1-84.
- Korpimaki, E. 1985. Rapid tracking of microtine populations by their avian predators: possible evidence for stabilizing predation. Oikos 45:281-284.
- Kuhk, R. 1953. Lautausserungen und jahreszeitliche Gesangstatigkeit des Rauhfusskauzes, Aegolius funereus (L.). J. Ornith., Lpz. 94:83-93.
- Lundberg, A. 1978. Bestandsuppskattning av Slaguggla och Parluggla. Anser, supplement 3:171-175.
- Lundberg, A. 1980. Vocalizations and courtship feeding of the Ural owl Strix uralensis. Ornis. Scand. 11:65-70.
- Lundin, A. 1961. Sang och laten hos Parlugglan, Aegolius funereus (L.). Fauna och Flora. 56:95-128.
- Marz, R. 1968. Der Rauhfusskauz (Aegolius funereus). Die Neue Brehm-Bucherei 394. Ziemsen, Wittenberg. 48pp.
- Meehan, R. H. 1980. Behavioral significance of boreal owl vocalizations during the breeding season. M. S. Thesis, Univ. Alaska, Fairbanks. 58pp.
- Mikkola, H. 1983. Owls of Europe. Buteo Books, Vermillion, S. D. 397pp.
- Norton, W. D., and D. W. Holt. 1982. Simultaneous nesting of northern pygmy owls and northern saw-whet owls in the same snag. Murrelet 63:94.
- Palmer, D. A. and R. A. Ryder. 1984. The first documented breeding of the boreal owl in Colorado. Condor 86:215-217.
- Reddall, J. (compiler) 1985. Additional 1985 reports. Lark Bunting 20:99.
- Santee, R., and W. Granfield. 1939. Behavior of the saw-whet owl on its nesting grounds. Condor 41:3-9.
- Schelper, W. 1972. Die boilogie des Rauhfusskauzes (Aegolius funereus L.). PhD. Diss., Universitat Gottingen.
- Sokal, R. R., and F. J. Rohlf. 1969. Biometry. W. H. Freeman, San Francisco, CA. 776 pp.
- U.S.D.A. Soil Conservation Service. 1984. Water supply outlook for Colorado and New Mexico. Washington D.C.
- Webb, B. E. 1982. Distribution and nesting requirements of montane forest owls in Colorado. M. A. Thesis, Univ. Colo., Boulder. 117pp.

Distribution and Status of the Boreal Owl in Colorado¹

Ronald A. Ryder, David A. Palmer,
and John J. Rawinski²

Abstract.--The Boreal Owl (Aegolius funereus) has been known in Colorado for over 90 years. Formerly listed as a rare winter visitor, the species has probably been a resident since the Pleistocene. Since 1979, intensive searches in northern Larimer County have documented four nestings. Apparently territorial Boreal Owls have been observed during the breeding season in 14 other counties. The species occurs mainly above 2900 m in climax spruce-fir (Picea engelmannii-Abies lasiocarpa) forests as far south as Wolf Creek Pass, 80 km north of the New Mexico border.

INTRODUCTION

The Boreal Owl (Aegolius funereus) has for years been considered a rare winter vagrant in Colorado (AOU 1957, Bailey and Niedrach 1965, Bent 1938, Karalus and Eckert 1974) and even some recent works do not show Colorado in the regular range of the bird (Alcorn 1986, Burton 1984, Godfrey 1986, Heintzelman 1984, Robbins et al. 1983). We therefore believe it useful to document the distribution and status of the species based upon records of specimens, photos, and field observations known as of 1986.

There is now considerable evidence that the Boreal Owl is a rather widespread species in sub-alpine forests throughout much of the state, with breeding season records as far south as Wolf Creek Pass (37°27'N, 106°52'W, elev. 3300 m), probably the southernmost known part of the species' range (cf. Voous 1960).

METHODS AND MATERIALS

Pertinent literature (both published and unpublished) was reviewed, primarily that in the Colorado State University Libraries, Fort Collins, and in the Denver Museum of Natural History. All known specimens (study skins, taxidermic mounts,

and skeletons) were examined to verify identifications and details regarding their collection. Records submitted to the Colorado Field Ornithologists were reviewed, as well as those received by Hugh Kingery, Regional Editor for American Birds. Notices concerning our interest in the dates and locations of sightings were distributed to Colorado Division of Wildlife and U. S. Forest Service field personnel as well as to active ornithologists. Intensive searches were conducted in the Cameron Pass area of Larimer and Jackson counties (Palmer and Ryder) and Spring Creek, Wolf Creek, and Slumgullion Passes areas of Mineral and Hinsdale counties (Rawinski).

Locating Owls

Owls were located by listening for their vocalizations along roads and ski trails within the Cameron Pass area from January through June 1980-86. On calm nights Boreal Owls can be heard from over 1.5 km (Bondrup-Nielsen 1978). Each location at which an owl was heard was plotted on a USGS topographic map (1:24,000). If possible, the exact singing tree was located. Slight disturbances did not seem to deter the singing activity or cause the owls to move to other areas. In the 1983-84 surveys on Cameron Pass, no tape recordings were used to stimulate singing activity because this might have caused the owls to move, hence biasing the singing location. Tape recordings were used in 1980-82 and in 1985-86 to elicit responses and when trying to capture owls.

During road surveys, the observer stopped every 0.8 km along designated roadways and listened for 5 minutes before driving to the next stop (cf. Holmberg 1979). When a census was skied or snowshoed there were no planned stops, but the observers listened for owls while moving, stopping occasionally to listen for distant owls.

The procedure used for locating Boreal Owls

¹Paper presented at the "Ecology and Conservation of Northern Forest Owls Symposium" 3-6 February 1987, Winnipeg, Manitoba, Canada.

²Ronald A. Ryder is Emeritus Professor of Wildlife Biology, Colorado State University, Fort Collins, Colo. David A. Palmer is a biologist with Wildlife International, 305 Commerce Dr., Easton, Md. John J. Rawinski is a soil scientist, Rio Grande National Forest, Monte Vista, Colo.

in the autumn was described by Palmer and Rawinski (1986).

Trapping Owls

Owls were trapped using mist nets and bal-chatri traps baited with a live mouse. Two 12 m by 2.6 m mist nets were set in a "V" formation and the bal-chatri trap, with the mouse, was placed at the closed end of the "V". Trapping began shortly after the owls began singing in the evening. Nets were placed in probable flight corridors within known Boreal Owl territories. A tape recording of the owl's primary song was broadcast from the area around the nets in order to attract the owl's attention. Captured owls were weighed, measured, banded, and equipped with a radiotransmitter.

Radiotelemetry

Male owls were equipped with transmitters using a criss-cross backpack attachment (Smith and Gilbert 1981) securing a 5-6 g single pulse transmitter with a 25 cm whip antenna. Because female owls frequently occupied a nest cavity, they were equipped with a 3-4 g transmitter attached to the central retrices using hot-melt glue (Bruggers et al. 1981) to avoid undue wear on the owl or the transmitter (Reynolds and Linkhart 1984). The larger transmitters had a range of approximately 3 km, ground to ground using a three element hand-held yagi antenna, while the 3-4 g transmitters had a range of about 1.5 to 2 km. Owls were recaptured to replace transmitters and to check on the owl's physical condition using either a telescoping pole with a mist net on the end (Reynolds and Linkhart 1984) or bal-chatri traps or mist nets placed by the roost site and baited with mice. Average life of the larger transmitters was 150 days, while the smaller ones had a life of about 60 days.

In 1983-84 in the Cameron Pass area attempts were made to locate the radio-equipped owls visually each day during the spring and summer and at least twice a week in the autumn and winter. At each roost the owls were observed for 0.5 to 2 h. Each roost location was plotted to the nearest 100 m on a USGS topographic map (1:24,000) using UTM (Universal Transverse Mercator) coordinates.

RESULTS

Specimens

Seventeen Boreal Owl specimens were located (9 study skins, 5 taxidermy mounts, and 3 skeletons). These specimens date back to 1896 (table 1). The first four were intentionally shot ("collected"), whereas all specimens preserved since 1970 were accidental deaths, primarily automobile roadkills. One (No. 14 in table 1) was caught in a kill-trap (Conibear) set for pine marten by another researcher. One specimen (No.9) was originally misidentified as a Saw-whet Owl

Table 1.--Known specimens of Boreal Owls collected in Colorado.

Date	Where Collected	Specimen Located ¹	Sex	Age
1. 14 Oct. 1896	Crested Butte, Gunnison Co.	DMNH	♂?	?
2. Nov. 1903	Pitkin County	UNC	♀	?
3. 11 Nov. 1929	Fraser Grand Co.	DMNH	♂	?
4. 14 Aug. 1963	Deadman Mt., Larimer Co.	CSU	♀	juv.
5. 1 April 1970	Estes Park, Larimer Co.	DMNH	♂	adult
6. 15 June 1973	Rabbit Ears Pass, Routt Co.	CSU	♀	adult
7. 2 Feb. 1978	Evergreen, Jefferson Co.	DMNH	♂	adult
8. 6 Feb. 1978	Estes Park, Larimer Co.	CSU	♂?	adult
9. Feb. 1979	Rustic, Larimer Co.	FCM	♂?	adult
10. 14 July 1979	Trail Ridge Rd., Larimer Co.	DMNH	♂	adult
11. 7 Sept. 1979	Rabbit Ears Pass, Routt Co.	DMNH	♂	adult
12. 17 Dec. 1979	Estes Park, Larimer Co.	CDW	♀	adult
13. 19 Dec. 1980	Ranger Lakes, Jackson Co.	CSU	♀	adult
14. 12 Feb. 1984	Long Draw Rd. Larimer Co.	CDW	♀	adult
15. 7 July 1984	Chambers Lake, Larimer Co.	DMNH	?	nestl.
16. 7 July 1984	Chambers Lake, Larimer Co.	DMNH	?	nestl.
17. 7 July 1984	Chambers Lake, Larimer Co.	CSU	?	nestl.

¹Key: DMNH = Denver Museum of Natural History; UNC = University of Northern Colorado, Greeley; CSU = Colorado State University; FCM = Fort Collins City Museum; CDW = Colorado Division of Wildlife, Fort Collins.

(*Aegolius acadicus*) but was definitely a Boreal Owl. Unfortunately it was later stolen, but we have several photographs and measurements on file. Two of the skeletons are of nestlings found dead in an abandoned nest; a third nestling drowned in a small pond below the nest, apparently as it fledged. Specimens numbered 1-4 are cited in Bailey and Niedrach (1965). An alleged specimen reported to have been taken by Carter near Breckenridge on 28 December 1882 and reported by Cooke (1900) was later considered to have been an error either in identification or record-keeping (Lincoln 1929). Bailey and Niedrach (1965) thought Cooke had mistaken it for a Saw-whet Owl that Carter collected on that date.

Photographs

Not only have all known specimens been photographed, but numerous visual observations have been supported with 35 mm colored slides, a few of which have been published in black and white (Calder and Calder 1972, Kingery 1981, Palmer and Rawinski 1986). A minimum of 16 different Boreal Owls are believed to have been photographed (table 2). Some, such as the males which were radiomarked by Palmer near Cameron Pass, were photographed literally hundreds of times by many different photographers. Excellent photos of fledglings and an adult feeding young were taken by Art Wolfe 24-25 July 1982 at a nest along Corral Creek in Larimer County (Bergman 1985).

Table 2.--Boreal Owl records for Colorado, 1896-1986.

County	Specimens	Photos	Observations	Totals
Larimer	9	9	60	78
Hinsdale	-	3	6	9
Jackson	1	-	7	8
Grand	2	2	1	5
Summit	-	1	4	5
Gunnison	1	1	2	4
Mesa	-	-	3	3
Routt	2	-	-	2
Mineral	-	-	2	2
Boulder	-	-	2	2
Delta	-	-	2	2
Jefferson	1	-	1	2
Pitkin	1	-	-	1
Rio Grande	-	-	1 (?)	1
Gilpin	-	-	1	1
Totals	17	16	91	124

Observations

More than 90 observations of Boreal Owls are known for Colorado, most since 1963 and largely based on calls, many solicited by tape recordings (tables 2 and 3). These observations have ranged from north of Chambers Lake, Larimer County (40°31'N, 105°53'W) south to Wolf Creek Pass, Mineral County (37°27'N, 106°52'W) (fig. 1).

Owl Locations Based on Intensive Studies

A total of 36 Boreal Owls (9 in 1983, 27 in 1984) were located during an intensive study on Cameron Pass (Palmer 1986). Boreal Owls were found in areas with elevations ranging from 2770 to 3170 m (table 4). Seven Boreal Owl territories were used both in 1983 and 1984.

The highest density of Boreal Owls was found above 3000 m in mature spruce-fir forest interspersed with numerous subalpine meadows (table 5).

Trapping

Four Boreal Owls (2 males, 2 females) were trapped in 1983-84. One female was caught in a

Table 3.--Breeding season observations of Boreal Owls in Colorado.

Year	Minimum Number	Type of observation	Counties
1963	1	Specimen of juvenile	Larimer
1966	1	Heard	Larimer
1967	3	2 heard, 1 seen	Larimer, Summit
1970	2	1 specimen, 1 seen	Larimer, Gunnison
1971	1	Photo of juvenile	Gunnison
1973	1	Specimen	Routt
1974	1	Juvenile seen	Larimer
1975	1	Seen	Gunnison
1978	2	1 seen, 1 captured and released	Grand
1979	3	2 heard, 1 juvenile specimen	Larimer, Grand
1980	5	Heard	Larimer
1981	12	2 seen, 10 heard, 2 photos	Larimer, Grand
1982	15	5 seen, 5 photos, 5 heard	Larimer
1983	12	2 seen, 9 heard, 1 photo, 1 specimen	Larimer, Grand, Jackson
1984	27	8 seen, 21 heard, 7 photos	Larimer, Hinsdale, Jackson, Jefferson, Rio Grande
1985	13	Heard	Mesa, Boulder, Mineral
1986	1	Seen	Gilpin

Table 4.--Elevations of Boreal Owl territories, Larimer County, Colorado, 1983-84 (Palmer 1986).

Elevation (meters)	Number of territories	
	1983	1984
2701 - 2800	1	4
2801 - 2900	1	3
2901 - 3000	1	3
3001 - 3100	2	6
3101 - 3200	4	11
Total territories	9	27

Table 5.--Composition of habitat within Boreal Owl territories, Larimer County, Colorado, 1983-84 (Palmer 1986).

Habitat type	% of Habitat within territories (N=21)
Aspen (<i>Populus tremuloides</i>)	0.4
Lodgepole Pine (<i>Pinus contorta</i>)	8.9
Water	3.5
Road surface	1.5
Rocky terrain	0.5
Meadow	11.0
Spruce-fir	70.1
Timber harvest	0.8
Alpine tundra	3.4

mist net 22 September 1983 near Fraser by Tom Nicholls and radioed by Palmer and Ryder. The males were trapped on 17 May 1984, and a female was caught beneath a nest on 11 June 1984.

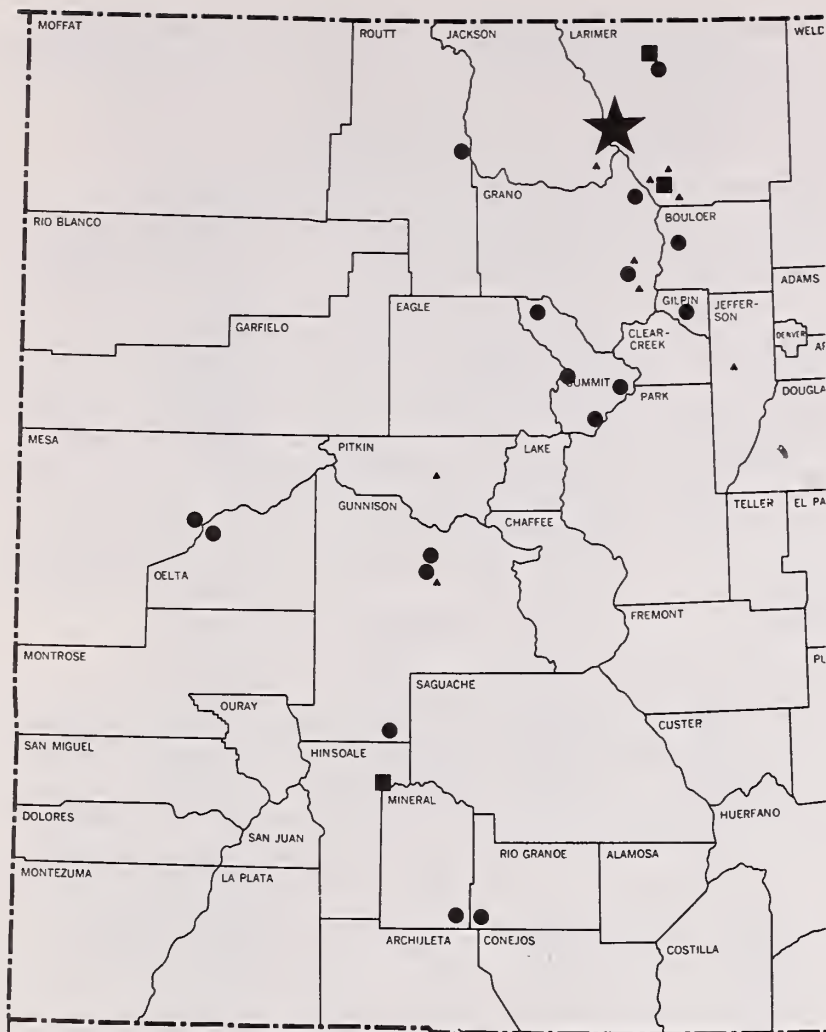

Figure 1.--Locations of Boreal Owl observations in Colorado. Breeding season records: ★ =>10; ■ = 6-10; ● = 1-5. Winter records: ▲ = 1-5.

Neither male was known to be nesting. Owls in 1984 were initially caught using a mist net baited with mice. Palmer found that playing tapes alone was not enough to attract the owls into the nets, but it did cause the owls to investigate the area and locate the mouse. The two males were recaptured a total of four times in order to replace the transmitters. Owls were recaptured for the first time using a telescoping pole with a mist net on the end, but when this method was tried on subsequent occasions the owls recognized it and avoided capture. A bal-chatri trap placed under a roost was successful once, and a mist net baited with live mice was used to recapture the owl on another occasion. Both of these methods were unsuccessful on subsequent capture attempts.

Roost Sites

One hundred seventy-four roosts (owls perched over one-half hour without moving) were located during the period (87 for radioed owl #1, 81 for #2 and 6 for #3) (table 6). Few data were obtained from the autumn-banded female. Only two roost trees were used more than once; one of these was used on consecutive days, while the other was used a week apart. All roosts were in coniferous trees. Engelmann spruce were chosen for roost trees significantly more (62.5%) than either subalpine fir (25.7%) or lodgepole pine (4.8%). No owls were found roosting in cavities.



Typical spruce-fir habitat in northern Colorado.

Feeding Ecology

Boreal Owls were observed hunting during the day on 27 occasions. Ten successful and three attempted kills were noted. On 10 other occasions, captive mice or birds were placed near an owl's roost in order to observe the owl's behavior, or in an attempt to recapture the owl. The general hunting techniques of Boreal Owls closely followed that described by Norberg (1970) except they often hunted during the day. Boreal Owls we observed often captured voles under moderate cover by plunging through the shrubs

Table 6.--Species of tree selected for roosts by Boreal Owls in north-central Colorado, 1984. Species of tree closest to the roost tree, a randomly selected tree, and the tree nearest to the random tree were used to test whether the owls preferred one species of tree in particular.

Tree Species	Roost tree	Nearest to roost tree	Random tree	Nearest to random
Engelmann spruce	116	67	76	79
Subalpine fir	48	96	79	78
Lodgepole pine	8	11	19	17
Total	174	174	174	174

Table 7.--Prey items taken by Boreal Owls in Larimer County, Colorado, 1981-84.

Prey species	Number and percent
Mammals	
<i>Clethrionomys gapperi</i>	39 (54.2)
<i>Peromyscus maniculatus</i>	1 (1.4)
<i>Microtus longicaudus</i>	9 (12.5)
<i>Microtus montanus</i>	9 (12.5)
<i>Sorex</i> spp.	4 (5.5)
<i>Eutamias minimus</i>	1 (1.4)
unknown	4 (5.5)
Birds	
<i>Turdus migratorius</i>	1 (1.4)
<i>Junco hyemalis</i>	2 (2.8)
<i>Parus gambeli</i>	1 (1.4)
unknown	1 (1.4)
Total	72

(*Vaccinium* spp. generally less than 10 cm tall) to get to the prey. Moving prey were captured more frequently than stationary prey, indicating that the owls may use auditory cues for locating prey even when the prey is clearly visible. No capture attempts were witnessed while there was snow on the ground, so it could not be determined whether the owls would penetrate beneath the snow to capture prey as reported by Nero (1980). Boreal Owls were seen with avian prey on three occasions, although the hunting technique used to capture them was not noted. Prey items as ascertained from observations, nest cavity contents, and analysis of regurgitated pellets are summarized in table 7.

Nesting

Four Boreal Owl nests were located during the period; one nest was used in consecutive years (Palmer and Ryder 1984). Two nests were in Engelmann spruce snags, and one was in a lodgepole pine snag. Nest heights were 6 m and 11 m in the spruce trees, 5 m in the lodgepole (table 8). Two Boreal Owl nests were in holes most likely excavated by Northern Flickers (*Colaptes auratus*) with entrance diameters of 80 and 78 mm, while the nest used in consecutive years was in a natural cavity with an entrance diameter of 100 mm. Probable nest initiation dates for the four nests were 17 April, 27 April, 10 May and 1 June.

Over 60 nest boxes, following Mebs (1966), were erected in the Cameron Pass area 1981-83. As of summer 1986, however, none had been used for nesting, although a few males were observed calling from near nest boxes.

DISCUSSION

After they collected a recently fledged Boreal Owl in north-central Colorado, Baldwin and Koplín (1966) theorized that the species "occurs in Colorado as a relict of a more widespread multilatitude Pleistocene population

Table 8.--Nestings of Boreal Owls in Colorado, 1981-84.

Year	Initiated	Nest Tree	Ht. of Cavity	Fate of Nest
1981	17 April	Lodgepole pine	5 m	4 eggs deserted
1982	1 June	Lodgepole pine	5 m	3 young fledged 1 egg dead
1984	27 April	Engelmann spruce	11 m	3 young, all died at fledging
1984	10 May	Engelmann spruce	6 m	1 egg deserted

of Boreal Owls." Such isolated breeding units in the Rocky Mountains would parallel a similar distribution throughout the species' Eurasian range (Myserud 1970). The densities that we estimate from Colorado are comparable to densities of owls estimated by Bondrup-Nielsen (1978) in historic Boreal Owl range in Alberta and Ontario, Canada.

Boreal Owls have been seen or heard recently throughout the Rocky Mountain region: Colorado, Wyoming, Montana, Idaho and Washington (Palmer and Ryder 1984, O'Connell 1987). Nests have been documented in Idaho (Hayward and Garton 1983, Hayward *et al.* 1987). These records seem to indicate that a contiguous breeding range extends in the Rocky Mountains from Canada south to Colorado, supporting the theory advanced by Baldwin and Koplín (1966). The accumulation of records in recent years is more likely a result of greater human penetration into the Boreal Owl's habitat during the peak singing period rather than an increase in owl numbers in the region.

These findings, in conjunction with the discovery of Boreal Owls nesting in Minnesota (Eckert 1979, 1980), should justify a revision of descriptions and maps of the species' breeding range in North America.

POSTSCRIPT:

Rawinski and Stahlecker heard, recorded the voice, and photographed a male boreal owl 19 April 1987 along Dixie Creek in the Carson National Forest, New Mexico. At 36° 59' 28" North Latitude, this is, as far as we know, the most southerly record yet reported.

ACKNOWLEDGMENTS

We thank the Colorado Division of Wildlife, especially T. Washington, W. D. Gaul, C. E. Braun and G. R. Craig for their support, and all those persons who willingly gave their time to aid in censusing: S. J. Palmer, T. L. and D. Manley, D. C. Delong, Jr., M. Janos, C. A. Chase III, R. Lambeth, K. J. Cook, J. F. Ellis, J. E. Richards, J. A. Sedgwick, A. W. Alldredge, M. A. Masteller, W. K. Reeser, E. L. Smith, B. E. Webb, several members of the Colorado Field Ornithologists.

LITERATURE CITED

- Alcorn, G. D. 1986. Owls, an introduction for the amateur naturalist. 176 p. Prentice-Hall Press, New York, N. Y.
- Bailey, A. M., and R. J. Niedrach. 1965. Birds of Colorado. Vol. I, 454 p. Denver Museum of Natural History, Denver, Colo.
- Baldwin, P. H., and J. R. Koplín. 1966. The boreal owl as a Pleistocene relict in Colorado. *Condor* 68:299-300.
- Bent, A. C. 1938. Life histories of North American birds of prey: falcons, hawks, caracaras and owls. Part 2. U. S. National Museum Bulletin 170:1-482.
- Bergman, C. A. 1985. Invaders from the far north. *National Wildlife* 23(6):34-39.
- Bondrup-Nielsen, S. 1978. Vocalizations, nesting and habitat preferences of the boreal owl (Aegolius funereus) in North America. 158 p. M.S. thesis. University of Toronto, Canada.
- Bruggers, R., J. Ellis, J. Sedgwick, and J. Bourassa. 1981. A radio transmitter for monitoring the movements of small passerine birds. *Proceedings of the International Conference on Wildlife Biotelemetry* 3:69-79.
- Burton, J. A., editor. 1984. Owls of the world. Second edition. 208 p. Peter Lowe, London, England.
- Calder, W. A. IV, and W. A. Calder, Jr. 1972. Juvenile boreal owl in Gunnison County, Colorado. *Colorado Field Ornithologist* 12:14.
- Cooke, W. W. 1900. The birds of Colorado: a second appendix to Bulletin 37, Agricultural College of Colorado. Experiment Station Bulletin 56:179-239.
- Eckert, K. 1979. First boreal owl nesting record south of Canada: a diary. *Loon* 51:20-27.
- Eckert, K. 1980. Another boreal owl nest found in Cook County. *Loon* 51:198-199.
- Godfrey, W. E. 1986. The birds of Canada. Revised edition. 595 p. National Museum of Natural Science, National Museums of Canada, Ottawa, Canada.
- Hayward, G. D., and E. O. Garton. 1983. First nesting records for boreal owl (Aegolius funereus) in Idaho. *Condor* 85:501.
- Hayward, G. D., P. H. Hayward, and E. O. Garton. 1987. Daily and seasonal movements of boreal owls in central Idaho. (This proceedings)
- Heintzelman, D. S. 1984. Guide to owl watching in North America. 193 p. Winchester Press, Piscataway, N. J.
- Holmberg, T. 1979. Point transect census of Tengmalm's owl--a methodological study. *Var Fagelvarld* 38:237-244.
- Karalus, K. E., and A. W. Eckert. 1974. The owls of North America. 278 p. Doubleday & Co., Inc., New York, N. Y.
- Kingery, H. E. 1981. Mountain west region. *American Birds* 35:848.
- Lincoln, F. C. 1929. In memoriam - Edwin Carter. *Condor* 31:196-200.
- Mebis, T. 1966. Eulen und Käuze. Strigidae. 134 p. Frackh'sche Verlagshandlung, Stuttgart.
- Mysterud, I. 1970. Hypothesis concerning characteristics and causes of population movements in Tengmalm's owl (Aegolius funereus [L.]). *Nytt Magasin Zoologi (Oslo)* 18:49-74.
- Nero, R. W. 1980. The great grey owl: phantom of the northern forest. 167 p. Smithsonian Institution Press, Washington, D. C.
- Norberg, R. A. 1970. Hunting of Tengmalm's Owl Aegolius funereus (L.). *Ornis Scandinavica* 1:51-64.
- O'Connell, M. W. 1987. Occurrence of the boreal owl in northeastern Washington. (This proceedings)
- Palmer, D. A. 1986. Habitat selection, movements and activity of boreal and saw-whet owls. 101 p. M.S. thesis, Colorado State University, Fort Collins, Colo.
- Palmer, D. A., and J. J. Rawinski. 1986. A technique for locating boreal owls in fall in the Rocky Mountains. *Colorado Field Ornithologist* 20:38-41.
- Palmer, D. A., and R. A. Ryder. 1984. The first documented breeding of the boreal owl in Colorado. *Condor* 86:215-217.
- Reynolds, R. T., and B. D. Linkhart. 1984. Methods and materials for capturing and monitoring flammulated owls. *Great Basin Naturalist* 44:49-51.
- Robbins, C. S., B. Bruun and H. S. Zim. 1983. A guide to field identification: birds of North America. 360 p. Golden Press, New York, N. Y.
- Smith, D. G., and R. Gilbert. 1981. Backpack radio transmitter attachment success in screech owls (Otus asio). *North American Bird Bander* 6:142-143.
- Voous, K. H. 1960. Atlas of European birds. 284 p. Elsevier, Amsterdam.

Movements and Home Range Use by Boreal Owls in Central Idaho¹

Gregory D. Hayward, Patricia H. Hayward,
and Edward O. Garton²

Abstract.--Radio-marked boreal owls moved an average minimum of 1265 m between consecutive day roosts. Winter roosts tended to be further apart than summer roosts. Boreal owls moved greater distances during years of lower prey densities. Males roosted an average distance of 2460 m from their nest. During a high prey year roost to nest distances were shorter than in subsequent years. Radio-marked owls used different home ranges during winter and summer. Summer activity centers shifted an average 2333 m from winter areas and increased in elevation by 230 m. The shift was probably due to the owls' need for cool summer roost sites and higher prey densities in high elevation spruce-fir forests. Year-round home ranges of 12 owls averaged 1528 ha (522-4119 ha), winter areas being larger than summer. Home ranges of adjacent owls overlapped extensively.

INTRODUCTION

Vertebrate movement patterns reveal resource requirements, degree of gene flow between geographic regions, level of population stability and the area necessary to support an individual in a particular environment. Information on movements and home range use by owls, however, is relatively difficult to gather due to their secretive behavior. Little is known about how these birds utilize space.

Although extensively studied in Europe, researchers have paid little attention to space use by the boreal, or Tengmalm's, owl. In North America, Bondrup-Nielsen (1978) followed two boreal owls in Canada and estimated their home ranges. Palmer (1986) intensively radiotracked two male boreal owls in Colorado in 1984 and reported movements and home range data. We are unaware of any other information on movements and use of space by this common forest owl.

Yearly movements by boreal owls have received greater attention than daily movements. Studies of yearly movements of boreal owls in the Old World (Lundberg 1979) indicate variation in site tenacity depending on environmental conditions and the sex of the individual. Site tenacity increases from northern to southern regions in Europe in response to snow cover and the amplitude and degree of synchrony of food fluctuations (Korpimaki 1986). In northern Sweden, male boreal owls are site tenacious between and during vole peaks while females are sedentary only during the vole peaks (Lofgren et al. 1986). Comparable information on site tenacity and nomadism is not available for North America, although Palmer's (1986) work also indicated a tendency toward a nomadic life strategy. Catling's (1972) information suggests the species is irruptive in eastern North America.

In this paper, we present preliminary information on the daily, seasonal, and yearly movement patterns in a recently discovered population of boreal owls in the mountains of central Idaho (Hayward and Garton 1983). Our paper is primarily descriptive. We do not intend to draw extensive ecological or life history conclusions from these data but rather present these preliminary results as an example of the movement patterns of a single population of boreal owls in North America.

¹Paper presented at the Northern Forest Owl Symposium, Winnipeg, Manitoba, Canada, February 2-7, 1987.

²Gregory D. Hayward is a Research Associate, Patricia H. Hayward a Research Associate, and Edward O. Garton a Professor of Wildlife Resources at the University of Idaho, Moscow, Id.

STUDY AREA

During the past three years we have studied habitat use by boreal owls (*Aegolius funereus*) in the mountains of central Idaho, USA. Our primary study area is Chamberlain Basin, located in the 850,000 ha Frank Church-River of No Return Wilderness. The basin, encompassing the headwaters of Chamberlain Creek, occupies about 25,000 ha of rolling mountain ridges rising from 1720 m to 2350 m elevation. The entire basin lies in the *Abies* life zone, and coniferous forest covers over 95 percent of the area. Lodgepole pine (*Pinus contorta*) dominates due to past fires (predominantly *Abies lasiocarpa* / *Calamagrostis rubescens* habitat type(h.t.)). Generally these stands are over 50 years old, some exceeding 120 years, and the forest structure is relatively open (tree spacing >2m). Large cavities are absent from these forests. At lower elevations, old-growth Douglas-fir (*Pseudotsuga menziesii*) and ponderosa pine (*Pinus ponderosa*) stands occupy southern aspects (predominantly *Pseudotsuga menziesii* / *C. rubescens* - *Pinus ponderosa* h.t.) and mature to old-growth Douglas-fir (predominantly *A. lasiocarpa* / *Vaccinium globulare* h.t.) grow on more mesic sites which have escaped fire. Forest stands on these sites are multi-layered and often quite open. Cavities excavated primarily by pileated woodpeckers (*Dryocopus pileatus*) are abundant in stands where ponderosa pine snags are available. At higher elevations mature to old-growth subalpine fir (predominantly *A. lasiocarpa* / *V. globulare* and *A. lasiocarpa* / *V. scoparium* h.t.) dominates. Wet spruce bottoms (*A. lasiocarpa* / *Streptopus amplexifolius* h.t.), aspen stands (*Picea engelmannii* / *Equisetum arvense* h.t.), sagebrush-bunch grass slopes, and willow carrs occupy relatively small areas within the basin.

Travel within the study area is restricted to foot, skis, or horseback. An extensive trail system provides access to most of the basin, most areas being no more than 3 km from a trail. The wilderness character of the area provides an opportunity to study the habitat use and movements of the owls in an area free from road building, logging, and other human disturbances, or man-made habitats which might influence movements of the owls.

METHODS

Beginning in February 1984, we captured boreal owls using mist nests and bal-chatri traps. Trapping was restricted to within 4.5 km of our living quarters in the extreme eastern edge of the study area below 1800 m elevation. The owls were marked with 6 g backpack-mounted radio transmitters (Wildlife Materials Inc. model MPB-1220-LD) with an expected battery life of 150 days.

We monitored the movements of radio-marked owls from approximately January through August each

of 3 years (1984-1986), recapturing the owls to replace the transmitters periodically. During each field season, we worked at alternate study sites for two, 2-week periods. Therefore, radio-marked owls were not followed continuously.

Using hand held 3-element yagi antennas, the radio signal was audible from 0.5 to 11 km, depending on the topographic position of the owl and receiver. If an owl could not be located by checking from ridgetops within about 8 km of our station, we thoroughly searched the entire area within 14 km radius of the station (the entire upper basin) from fixed-wing aircraft.

We located radio-tagged owls on their daytime roosts and plotted the locations on 1:24,000 topographic maps. These locations were converted a cartesian coordinate system using the UTM system; locations were recorded accurate to 100 m.

In 1984, the marked owls were relocated on an irregular schedule ranging from 1-4 locations every ten days. In 1985 and 1986, we maintained a more regular schedule locating each owl every 2-3 days. Three times in 1986 we located an owl on its daytime roost on at least four consecutive days (different owls in each case). These locations provided some insight into day-to-day movements by the birds.

Each time we located an owl we spent one hour at the roost recording habitat information and observing the bird. On 17 occasions we watched birds on their daytime roosts for over two hours to document movements. In addition, on six days, an owl found actively hunting during daylight hours was followed to document foraging movements. On six nights we followed boreal owls during the first few hours of foraging activity. Night vision goggles used in conjunction with radio-telemetry aided in nocturnal observations. Three owls were marked with betalights (Hayward, in review) to further facilitate observation of the owls.

Analysis

In the analysis of distances between roost sites used on consecutive days or two days apart, the sampling units were mean distances for individual owls. The measurements of distances between roosts were considered subsamples and the mean distance between consecutive roosts (or roosts used two days apart in the second analysis) was calculated from these values. This procedure avoids problems of pseudoreplication; the distances between several roosts used by an individual owl can not be considered independent (Hurlbert 1984).

The analysis of roost to nest distances was limited to four male owls. The limited sample of owls constrained the analysis such that the sampling unit was each roost to nest distance.

Home range analysis was performed using the computer program HOME RANGE (Samuel et al. 1985) which computes home range estimates using three methods. Home range size was estimated using a

modification of Dixon and Chapman's (1980) harmonic mean measure of activity, Jennrich and Turner's (1969) bivariate normal ellipse, and the minimum convex polygon. Because the latter two estimates are not distribution free, as is the harmonic mean, we tested the distribution of owl relocations against the assumed distributions. If over half the owl home ranges differed from the assumed distribution for either the bivariate normal or minimum convex polygon we rejected those methods for a majority of the remaining analysis. Due to the prevalence of polygon home range estimates in the literature, however, we reported these estimates. In addition, our preliminary analysis of home range overlap calculates percent overlap using convex polygon estimates. We prefer to compare utilization distributions, but because our investigation is not complete, we have limited analysis to the current approach.

Prior to home range analysis we screened the input data for outliers, representing distant excursions from the normal activity areas. Extreme observations inevitably plague home range studies (Schoener 1981). Outliers in a bivariate test, defined as those points with bivariate normal weights lower than 0.6, were considered for removal. If the point represented a movement to an area over two km from the owl's normal use area and was used for less than three days, the point was removed.

Throughout the paper we have divided our field season into two periods, snow free and snow covered, which I will refer to as summer and winter. The period of snow cover each year was defined as the period from January (we entered the field in January each year) until over 50 percent bare ground was exposed on level ground at 1800 m.

All confidence intervals are calculated for $\alpha=0.05$, as are statistical tests. The information below summarizes the movement patterns of 12 boreal owls. Our sample of movements varied widely among owls (Table 1).

RESULTS

Daily Movements

We located consecutive daytime roost sites of 12 owls (4 females, 8 males) on 94 occasions. We feel these observations give an index of the minimum distance which the owl foraged during the previous night. Our evidence indicates that the daytime roost is likely near the end of the final foraging bout. Boreal owls observed foraging during daylight chose roosts within 50 m of their final foraging perch.

Distances between roosts on consecutive days ranged from 0 to 6816 m; mean distance being 1265 ± 374 m (Table 2). During winter consecutive roosts tended to be further apart than during summer. Mean distance, however, did not differ

Table 1. Monitoring period and number of relocations for radio-marked boreal owls at Chamberlain Basin. Only owls relocated on at least 10 occasions are included. The distribution of relocations for owls highlighted by * was significantly different from bivariate normal ($p > 0.10$) and those marked by t were significantly different from bivariate uniform ($p > 0.10$).

Boreal Owl	Sex	Monitoring Period	Number of Relocations	
			Winter	Summer
B033*	M	16 Mar - 22 Sep 1984	4	9
B034 ^t	F	31 Jan - 22 Sep 1984	10	9
B037* ^t	F	5 Feb - 22 Sep 1984	16	8
B042	M	15 Feb - 22 Sep 1984	8	16
B043* ^t	M	15 Feb - 5 Jul 1984	5	2
		17 Mar - 21 Aug 1985	19	14
		15 Jan - 29 Jan 1986	3	
B055* ^t	F	19 Mar - 7 Jul 1984	9	2
		23 May - 20 Oct 1986		41
B076* ^t	M	18 Feb - 22 Aug 1985	24	19
B077*	M	18 Feb - 20 Aug 1985	31	14
B084*	M	31 Mar - 30 Aug 1985	12	17
		14 Jan - 29 Jan 1986	2	
B095 ^t	F	11 Mar - 7 May 1986	12	
B096* ^t	M	26 Apr - 20 Oct 1986	5	53
B097* ^t	M	25 Mar - 7 Jul 1986	13	27

significantly (winter: $n=11$ owls, $\bar{x}=1460 \pm 433$ m; summer: $n=7$ owls, $\bar{x}=868 \pm 483$ m). Three boreal owls in Colorado, averaged 708 m between consecutive day roosts (Palmer 1986).

Because we rarely located owls on consecutive days, we used distances between roosts located two days apart as a second index of the distance traveled by owls during their daily activities. This index provided a second sample with which to test differences in movement patterns between seasons and years.

Owls moved further between roosts in winter than summer but again, the differences were not significant (pooled data from the three years: winter $n=9$ owls, $\bar{x}=2204 \pm 1071$ m; summer $n=7$ owls, $\bar{x}=1069 \pm 427$ m). Considering winter and summer movements within any one year, differences were not significant. Point estimates of the mean, however, are all larger for winter than summer (Table 3). From 1984 through 1986, our indices of small mammal abundance declined (authors' unpublished data). Through this period of declining food supply, both winter and summer movements showed a trend toward longer movements between roosts (Tables 2 and 3). Although means are not significantly different, point estimates of the means consistently increased over the three years.

Another index of the minimum distance traveled by boreal owls during daily activity is provided by the distance between roost and nest sites of male owls during the nesting seasons. The mean distance between daytime roosts and the nest sites of four

Table 2. Ninety-five percent confidence intervals on the mean distances, in meters, between roosts used on consecutive days. Sample size in parentheses.

Year	Winter	Summer
1984	973±317(4)	502±5734(2)
1985	1638±897(4)	277±1993(2)
1986	1585±1399(4)	1157±1243(3)
Pooled (1984-1986):		
	1460±433(11)	869±483(7)

owls was 2460 m (±473m). Male owls rarely roosted within 500 m of the nest sites and on only one occasion ($n=43$) did a male boreal owl roost within 100 m of the nest site. Over 75 percent of roosts were located over 1000 m from the nest and up to 5600 m from it. The distance between roosts and nest sites showed no significant tendency to increase or decrease during the course of nesting (incubation through fledging). In 1984, when our index of prey availability was higher than the following years, roost to nest distances were significantly less than those measured for an owl in 1986 (Table 4).

Although radio-telemetry (triangulation) indicated male owls did some foraging near the nest site, we feel the birds frequently foraged at the distances indicated by the roost to nest distances. Following prey deliveries at the nest on three nights, one owl returned to the area of its daytime roost several km from the nest. During the incubation period, male owls generally visited the

Table 3. Ninety-five percent confidence intervals on the mean distance, in meters, between roosts located over a three-day period (one day separating each roost location). Subsamples are unequal among owls and reported sample sizes indicate the number of owls. Data include 130 distances.

Year	Winter	Summer
1984	1335±1390(3)	
1985	1753±430(5)	802±1192(3)
1986	4551±10,323(2)	1380±751(3)
Pooled (1984-1986):		
	2205±1071(9)	1069±427(7)

Table 4. Distance in meters between daytime roosts and an owl's nest site for male boreal owls during incubation and nestling periods.

Year	Owl	n	Mean ± 95% Bound	Range
1984	B033	6	1676(±383)	1334-2062
	B042	9	1333(±865)	100-3220
1985	B077	3	4096(±2825)	2802-5166
1986	B097	25	2886(±667)	583-5608

nest 1-3 times each night. Later in the breeding season the male may visit the nest as many as 10 times in a night.

Foraging

Observation of hunting owls on ten occasions, totaling 18.6 hrs, provided some indication of travel rate, distances between hunting perches, and duration of perches--measures of hunting behavior. During these observations, the owl was not always visible, so some hunting perches used very briefly were overlooked.

We measured the total distance covered by the foraging owl during the observation session by plotting its path on 1:24,000 topographic maps. Although these measurements are not particularly precise, they can be used to calculate a minimum travel rate while foraging (by dividing by the observation period). Foraging owls traveled from 1 to 36 m per minute with a median rate of 10 m/min for the 10 observation sessions. The owls remained on each hunting perch from a matter of seconds to over 1/2 hr ($n=94, \bar{x}=6.35 \pm 1.6$ min). Prior to locating prey, the owls tended to move more rapidly, remaining on each perch 2-4 minutes. After detecting prey, however, an owl often remained on a perch for over 10 minutes before pouncing on the prey.

The distance traveled between perches was not always estimated, but for sixty estimated distances, the mean flight distance was 33 m (±8.3 m). This estimate is negatively biased as flights longer than 50 m often could not be estimated because the owl moved again before the perch was located.

While foraging, the owls concentrated their activity in a relatively small area compared to the total length of the foraging flights. The owls we followed doubled back frequently, and thus covered a relatively small rectangular area rather than a long narrow path.

Diurnal Movements

Owls were generally sedentary during daylight, rarely moving more than 50 m. Frequently, however, the roosting birds became active during mid-day and moved 5-20 m to a new roost or to cached prey. In 1986, movements from roosts were often associated with retrieval of cached prey, avoidance of sun, or disturbance due to high winds. On 17 occasions when roosting owls were observed more than two hours, the owl changed roosts 71 percent of the days. The new roost was an average of 27 m from the first roost. Palmer (1986) noted roost changes during 56 percent of observations.

Although not quantified, we noted an increase in diurnal foraging over the three year period. In 1984, we rarely observed our radio-marked owls foraging during daylight. In 1985, four marked owls occasionally hunted during the day. During the autumn of 1986, however, we observed two marked owls hunting nearly one third of the days radio-tracked. This frequency was higher than at any other observed period. Palmer (1986) observed hunting on 15 percent of summer locations.

Seasonal Movements

Radio-marked owls consistently used different home ranges during winter and summer. Harmonic mean center of activity (defined by the minimum harmonic value in an analysis of roost locations (Samuel et al. 1985)), shifted a mean of 2333 m (± 1518) between winter and summer for seven owls (limited to birds with 8 or more locations each season). Six of these owls used summer home ranges to the west of winter areas. The smallest shift between winter and summer activity centers was made by the only owl whose activity center moved eastward. Our study area generally rises in elevation from east to west indicating that roost locations shifted to higher elevations in summer. In fact, the elevation of winter ($n=10$, $\bar{x}=1807\pm 71$ m) and summer ($n=11$, $\bar{x}=2038\pm 121$ m) activity centers was significantly different. Considering only owls with over eight observations in each season, the difference in elevation was also significant ($p=0.008$, Wilcoxon matched pairs sign rank).

Nest sites of radio marked owls (5 nests), were all located in the lower 1/3 of the study area. During the winter prior to nesting, the home range activity center for five marked owls (3 females, 2 males) could not be shown to differ from the nest location (mean distance of activity center to nest, 1364 ± 1927 m; not significantly different from zero). Summer home ranges defined by roost locations, however, were not centered on nest sites but averaged 2126 m (± 1967 m) away (2 females, 5 males). Nest sites were generally on the periphery of summer home ranges.

During nesting, female activity was restricted to the immediate vicinity of the nest. During incubation the female left the cavity once or twice during the night for about 15 minutes, flying 30-60 m (observations at three nest sites and camera records at another). After the eggs hatched, she

left more frequently but only for brief periods (10-20 min) and one female was observed (through night vision goggles) carrying debris from the nest.

Female behavior following the brooding period (generally to nestling age of 20-25 days) was variable. Considering radio-marked females at four nests which produced fledglings, on only one occasion did a female consistently participate in feeding the young. One female moved out of the study area when she left the nest (young 21 and 23 days old) and another female who nested in 1984 and 1986 was only known to have delivered prey to the young on two nights in 1986 after leaving the nest three days earlier. She remained in the basin following nesting but concentrated activity about 5 km from the nest. In this case the male owl had abandoned the nest six days before she left and the young ultimately perished.

Home Range

In this section, we would like to summarize preliminary information related to how the owls utilize space. How did the owls distribute their use of space throughout their home range? What differences, if any, exist in utilization distributions between winter and summer? How large are intensively used areas (i.e. core areas)? And how broadly do seasonal home ranges overlap among owls? These results, however, must be considered preliminary as we have not completed fieldwork and, due to time constraints, the analysis has not included some sophisticated techniques for dissecting the internal anatomy of home range (Samuel and Garton 1985).

Here we define the home range as that area traversed by the individual in its normal activities of food gathering, mating and caring for young (Burt 1943). The utilization distribution (UD) describes the proportion of total activity that takes place in a given area. The UD, then, is useful in describing how an individual uses space within its home range in relation to environmental features. Core areas are those portions of the utilization area used more frequently than others.

We analyzed the home ranges of twelve radio-tagged owls monitored for various periods from 1984-1986. We compared the distribution of relocations for seasonal and overall home ranges to a bivariate normal and bivariate uniform distribution to test the underlying distributions required for the Jennrich and Turner (1969) and minimum convex polygon methods (Samuel and Garton 1985). Samuel and Garton (1985) suggested a minimum of 30 relocations and $\alpha=0.10$ for sufficient power to test the assumed distributions. Considering seasonal and overall samples with over 30 relocations, we rejected the assumption of bivariate uniformity in 8 of 10 cases and rejected the assumption of bivariate normality in 9 of 10 cases. Due to this high rejection rate we preferred a distribution free analysis utilizing the modified harmonic mean UD (Dixon and Chapman 1980) in the program HOME RANGE (Samuel et al. 1985).

Home ranges of boreal owls in Chamberlain Basin were quite large. Considering our locations of twelve owls (each with 10 or more relocations) 85 percent UD's covered an average of 1528 ha (± 687) (Table 5). The large overall utilization distributions (range of 85 percent contours 522-4119 ha) reflect the shift in areas used in winter and summer.

Mean seasonal home ranges were substantially smaller than the respective overall home range (Tables 5,6). This difference could be due to a smaller sample of locations for seasonal home ranges or simply show that smaller areas are used in any one season than the year round home range. Our simulations (unpublished data) indicate that harmonic mean measures of home range are slightly influenced by sample size but not to the extent seen in Tables 5 and 6. Furthermore, correlations between sample size and home range size from the owl data were low. In seven of nine tests, correlations were below 0.3. We conclude that the area required to support an owl during a given season appears to be less than the area required to meet the birds' needs for an entire year. No difference can be shown for mean area of UD's between seasons (t-test, Table 6). A Wilcoxon matched pairs, sign rank test ($n=5, p=0.125$), considering only owls with at least eight locations for each season, also showed no seasonal differences.

Table 5. Home range size of boreal owls at Chamberlain Basin. Percent utilization distributions (UD's) were calculated using the program HOMERANGE (Samuel et al 1985). Minimum convex polygon estimates are reported only for comparison with literature as few distributions corresponded to the assumed bivariate uniform for this estimate.

Year	Owl	n	Area of UD (ha)			Minimum Convex Polygon (ha)
			35%	55%	85%	
1984	B033	13	158	311	639	557
	B034	19	72	168	522	627
	B037	24	335	931	2723	2688
	B042	24	102	343	602	776
1985	B043	35	332	812	1813	2789
	B076	43	269	623	1992	1052
	B077	46	308	922	1937	1736
	B084	29	291	681	1490	1555
1986	B055	40	83	445	886	2293
	B095	12	77	278	534	3496
	B096	57	187	478	1076	1098
	B097	40	709	1357	4119	2507
Mean \pm 95% Bound			244 \pm 114	612 \pm 220	1528 \pm 687	

Table 6. Seasonal home range size (ha) of boreal owls in Chamberlain Basin with 10 or more relocations. See text and Table 5 for details on calculating the estimates.

Season	Year	Owl	n	Area of Utilization Distribution			
				35%	55%	85%	
Winter	1984	B034	10	26	113	311	
		B037	16	87	303	970	
	1985	B043	19	159	429	1170	
		B076	24	121	313	1057	
		B077	31	283	669	1714	
	1986	B084	12	152	357	807	
		B095	12	77	277	534	
		B097	13	121	351	1962	
	Mean \pm 95% Bound				128 \pm 62	352 \pm 130	1070 \pm 464
	Summer	1984	B042	16	113	168	523
B043			14	2	197	446	
1985		B076	19	8	56	158	
		B077	14	124	427	924	
		B084	17	63	335	1030	
1986		B096	53	148	361	820	
		B097	27	236	739	1837	
		B055	40	190	423	1023	
Mean \pm 95% Bound				111 \pm 69	338 \pm 173	845 \pm 421	

The owls concentrated their activity in a small portion of their seasonal home ranges. In general, this is demonstrated by comparing the areas encompassed by the average 55 percent and 95 percent harmonic contours for winter and summer which indicates the owls concentrated over half of their activity in one quarter of the home range. In winter the mean 55 percent harmonic contour for 8 owls encompassed 24 percent of the area circumscribed by the mean 95 percent contour. Likewise, the ratio for summer was 30 percent of the area. During any one season, most owls concentrated their activity in two or three areas within the home range and explored other areas infrequently. The owls rarely stayed in a particular area for more than two to three weeks; rather, they moved among two or three core areas. Relocations of two owls demonstrate the pattern of use confined to particular core areas (Figs. 1,2). The summer home range of a male boreal owl (B096) shows three areas of relatively high use separated by unused forest (Fig. 1). The winter home range of another male (B077) exhibits this same pattern of non-uniform use of space (Fig. 2).

Home Range Overlap

Seasonal home ranges of radio-marked owls overlapped extensively each year of the study. Because of the low number of relocations for each owl in 1984, we restricted analysis of overlap to the last two years. In the winter 1985, the home range of B077 (estimated by minimum convex polygon) encompassed 82 percent of the area used by B084. The complementary overlap (B084-B077) was 43 percent (Fig. 3). Measurements and behavior indicated both owls were males. During summer 1985 these same owls overlapped 51 percent (B084-B077) and 80 percent (B077-B084). In the summer and autumn 1986, three adjacent owls, including a mated pair and another male from a failed nest used much

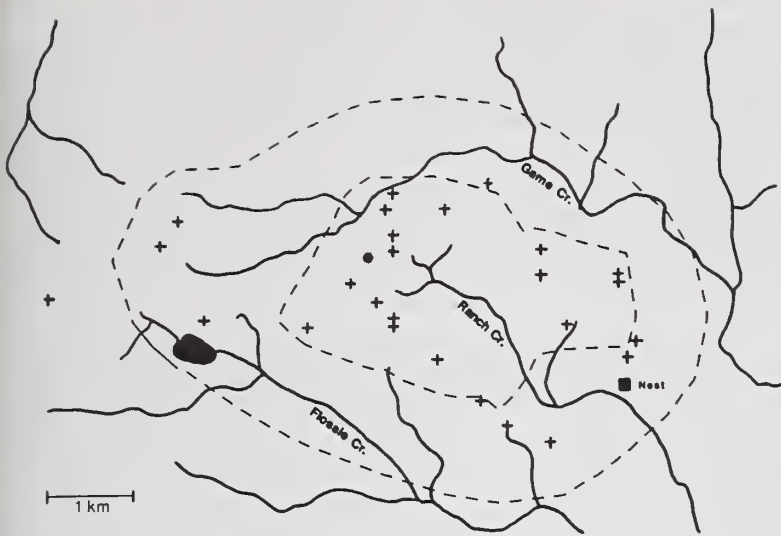

Figure 1.--Summer home range of a nesting male boreal owl. Concentric lines represent 95 percent and 55 percent utilization distribution contours. A "+" indicates individual locations; "*" represents the activity center.

of the same area (Fig. 4). Overlap values among these three owls ranged from 21 to 80 percent and averaged 51 percent. The two males' home (BO96, BO97) ranges overlapped 39 and 63 percent.

The degree of overlap in use of space among unmated boreal owls was further demonstrated in daily radiotracking records. On 1 May 1986 two males, each known to be singing nightly at nest sites separated by 2.4 km were found roosting within 200 m of one another. On the night of 14 February 1984, three boreals, two known to be males, were caught in the same mist net. Likewise,

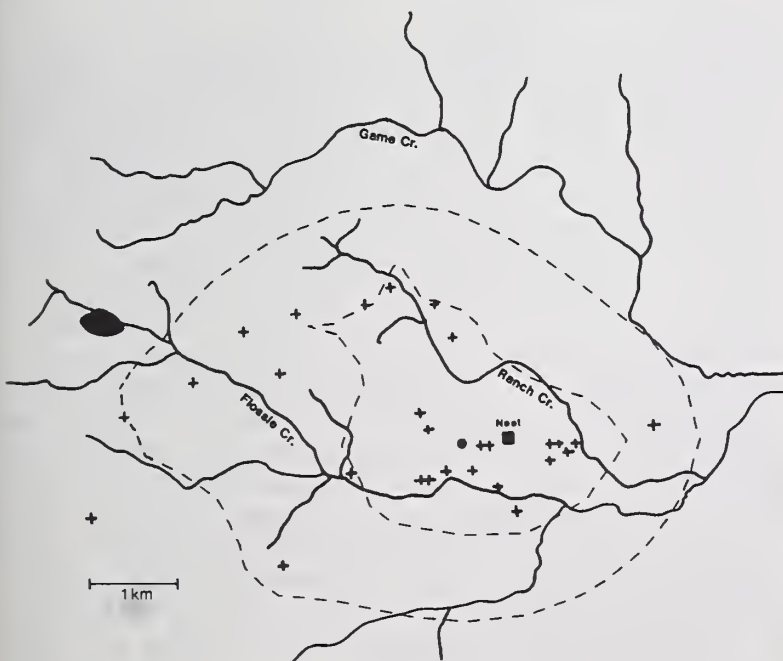

Figure 2.--Winter home range of a male boreal owl who nested the following May. See Figure 1 for details.

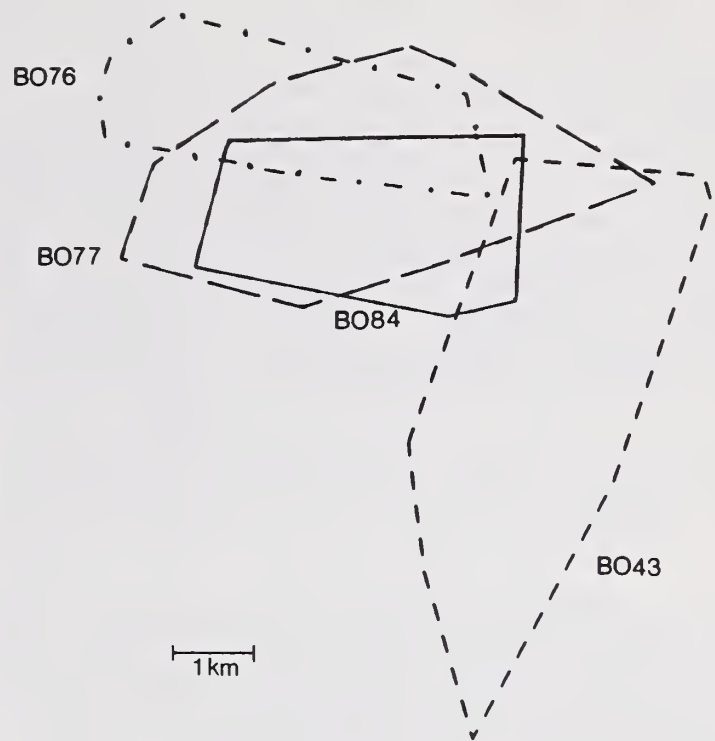

Figure 3.--Home range overlap among four male boreal owls during the winter 1985.

on 18 February 1985, two males were caught in a mist net. Two owls which ultimately mated were located roosting within 10 m of one another on 23 March 1984, 0.9 km from the nest of that year. On five other occasions prior to nesting, however, the members of the pair were never less than 1 km apart.

Year to Year Movements

Movements of radio-marked owls provide some indication of the degree of site tenacity in the Chamberlain Basin population. Four owls, one

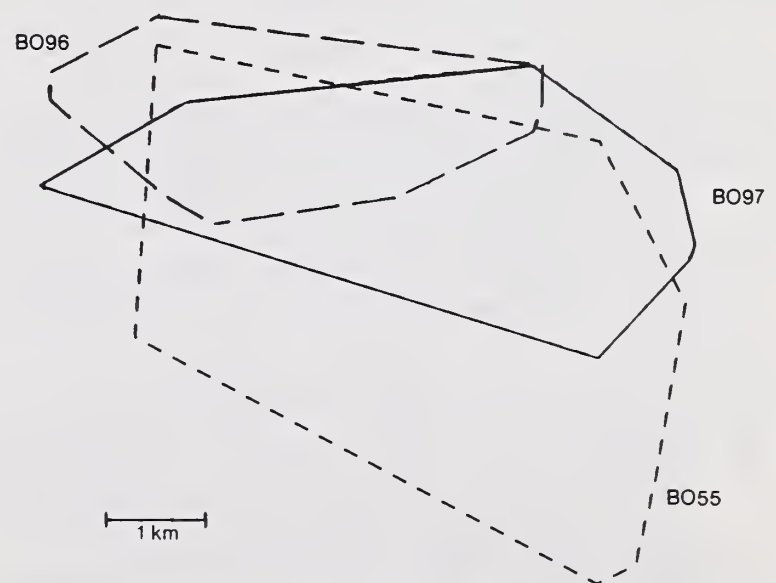

Figure 4.--Home range overlap among three boreal owls during summer 1986. Boreals 97 and 98 were a mated pair, 97 being the male. Boreal 96, a male, attracted a mate who abandoned prior to laying.

female and three males, were found in the Basin in more than one year. The female nested with a different mate in 1984 and 1986 in cavities 1.4 km apart. A male captured 14 February 1984 was recaptured 17 March 1985, 0.5 km away from his first capture site. This owl (B043) wore an active transmitter from March 1985 through January 1986 when it moved out of the basin with a fresh (11 day old) transmitter. A second male (B085), captured at its nest in 1985, was using a home range within several km of the nest February 1986 when it died (cause thought to be starvation). The third male, first captured in March 1985 (B084) was using a similar home range in February 1986 when it left the basin (same two week period as B085 died and B043 left). This owl's radio signal was relocated on 7 May 1986 80 km to the west near Upper Payette Lake, Valley Co., Idaho.

One female was thought to have left the basin within 8 days after she first left her nest. On 5 July, when her young were 20 and 22 days old, the owl was roosting near the cavity at 2100 h, the first day she was found off the nest. By 2207 h she was moving from the nest and could not be located until 13 July when a faint signal was heard about 7 km from the nest. The radio signal was never heard again.

A male also appeared to have left the Basin when he abandoned his nest 17 days into the nestling period. A camera at the nest failed to register any nest visits the night after we first failed to locate his radio signal. Whether the owl was killed by a predator, which also destroyed the radio, or the bird left the region is unknown.

DISCUSSION

Our results reveal six important features about boreal owls at Chamberlain.

- 1) Boreals used large seasonal areas for birds of their size.
- 2) Differences in seasonal home range and movements indicate that resource requirements likely differ substantially between seasons, and at Chamberlain all those requirements are not met within one forest type.
- 3) Use of space within seasonal home ranges was not uniform but concentrated in particular core areas.
- 4) The owls did not maintain exclusive territories but overlapped broadly in seasonal home ranges.
- 5) During the period of declining prey resources (1984-1986), the distances moved between roosts tended to increase.
- 6) The pattern of year to year occupancy indicated a mixture of nomadic and sedentary behavior.

Boreal owls used extremely large areas at Chamberlain. Despite our relatively small sample of relocations, estimated home ranges were larger

than the 1-5 km² reported by Bondrup-Nielsen (1978) for boreal owls in Canada. Home range sizes for three males in Norway ranged between 94 and 226 ha (Jacobsen and Sonnerud, these proceedings). Breeding season minimum convex polygon home range estimates for two Colorado male boreal owls (240 and 352 ha, minimum convex polygon) (Palmer 1986) were similar to summer home ranges calculated for two males nesting in our study area the same year (317 and 335 ha).

Home ranges reported for other species are also substantially smaller than Chamberlain boreal owls. Forsman et al. (1984) cited home ranges less than 2000 ha for spotted owls (*Strix occidentalis*), while Forbs and Warner (1974) reported 113 ha home ranges for Michigan saw-whet owls (*Aegolius acadicus*). Smith and Gilbert (1984) calculated 103 and 130 ha home ranges for Connecticut screech owls (*Otus asio*) radiotracked for five months (January - May). Boreal owl home ranges fell within the range reported for the large eagle owl (*Bubo bubo*) of Europe (1400-15,000 ha) (Mikkola 1983). The use of such a large area by a relatively small owl indicates either low resource abundance or that areas of resource concentration are widely dispersed.

In the heterogeneous habitat at Chamberlain, all resource requirements were not met by contiguous forest stands. Thus, seasonal requirements were satisfied in different areas. This feature is reflected in changes in location of home ranges from winter to summer accomplished by a shift to higher elevations in summer, and by the consistent trend for winter movements to be longer than summer. Also, the nest site was never centered in home ranges, rather, roosting and foraging habitat was chosen distant from the nest site. In Colorado, the home ranges of boreal owls shifted after the breeding season (Palmer 1986). Such a shift might also indicate changing resource needs and availability.

In winter, movements are likely primarily directed toward securing sufficient prey to meet daily maintenance costs. Specific areas may be used because they provide higher than average prey availability or lower the owls' average energy costs. Our observations indicate that daytime roost requirements play little role in dictating winter movements and home range. In summer, however, roost site requirements may be partly responsible for the shift to high elevations away from the nest site. Boreal owls are easily heat stressed; guller fluttering by inactive roosting owls occurred at temperatures as low as 75°F. Prey availability might also play a role in choice of space during summer since the same cool, mature forests which provide optimum summer roosts also have the most abundant small mammal populations (unpublished data). Areas of abundant cavities were distant from the high elevation forests so that nest sites were usually distant from roosting and foraging areas.

The concentration of activity in small portions of seasonal home ranges in Chamberlain and

suggestion that forest stands varied in their value to boreal owls. Future analysis comparing the habitat within core areas to less used portions of the home range may indicate what features of forest structures and composition are important in boreal owl habitat.

Territories of boreal owls in Europe (Solheim 1983) and Canada (Bondrup-Nielson 1978) have been characterized as simple breeding territories with no defense of foraging areas. Only a small region around the nest is defended as an exclusive area. Our information shows that boreal owl movements are not influenced by conspecifics and overlap among owls is substantial. In Norway, male boreal owls averaged 56% overlap (Jacobsen and Sonerud, these proceedings). Palmer (1986) also found two male boreal owls overlapping as much as 98 percent in early summer. Defense of the large foraging areas used by the owls would be difficult if not impossible.

From 1984-1986, during a period of declining small mammal abundance, home range size tended to increase as well as the length of day to day movements. Faced with lower prey availability, two basic strategies may be employed. First, the owls may conserve energy through reduced foraging activity and/or reproductive expenditure. An alternative strategy is to increase foraging effort at the expense of other activities. Increased activity may make the owls more vulnerable to predation. During winter, a majority of the energy expenditure is for self maintenance. Because boreal owls are relatively small birds, they cannot rely on accumulated reserves for extended periods. A strategy of energy conservation, therefore, is not feasible. Instead, the owls appeared to search over progressively larger areas as prey resources declined.

During summer, energy expenditure may be directed toward reproduction as well as self maintenance. The range of strategies to cope with reduced prey is, therefore, increased. Breeding efforts may range from failure to initiate nesting through raising a large brood, with corresponding variation in energy expenditure. At Chamberlain, the number of calling owls decreased and frequency of nest abandonment increased as prey resources declined indicating a reduction in reproductive expenditure. In addition, summer home ranges and daily movements increased from 1984-1986.

Populations of boreal owls vary in the degree of site tenacity or nomadism which they exhibit. In Europe, there is a general trend for increased nomadism in more northern populations (Korpimaki 1986). Korpimaki (1986) found that within Finland the degree of nomadism was positively correlated with winter snow depth. Lundberg (1979) hypothesized that due to the conflicting pressures of food stress favoring nomadism and nest site scarcity favoring site tenacity, the movement pattern of male and female boreal owls differ. He hypothesized that males would exhibit site tenacity and females nomadism. Lundberg's reasoning finds support from theory and empirical evidence. The

large potential clutch size of boreal owls and cyclic pattern of food production fit Andersson's (1980) model for a species likely to exhibit nomadism. On the other hand, von Haartman (1968) showed that residency was favored by the increased reproductive output afforded by early nesting in cavity nesters. Wallin and Andersson (1981), Solheim (1983), Lofgren et al. (1986) and Korpimaki (1986) have demonstrated that boreal owls exhibit both site tenacity and nomadic tendencies. In the most intensive investigation, Lofgren et al. (1986) showed that males were site tenacious throughout a prey cycle whereas females were tenacious only during prey peaks.

Our owls also showed a mixed strategy of site tenacity and nomadism, but differences between sexes were not clear. Some males and females remained in the study area during a period of declining prey. Both sexes also exhibited nomadism during the same period. The only individual located far from the study area was a male, but several others disappeared from the area and were never relocated. In Colorado, Palmer (1986) also observed a tendency toward nomadism in both male and female owls.

Deep snow (0.5-2.0 m) which remains in our study area for five months each year and relatively low prey populations likely contribute to the nomadic character of the boreal owl population at Chamberlain. Winter prey scarcity may frequently force many owls to search elsewhere for food. Conversely, if prey populations fluctuate but do not exhibit a cyclic pattern, the tendency for nomadism should be reduced (Andersson 1980). Small mammals in the Rockies have not been shown to be cyclic. The conflicting forces of severe winter food scarcity but lack of a consistent cycle may be responsible for the mixed pattern of site tenacity and nomadism.

SUMMARY

The boreal owls we studied moved over large home ranges throughout the year. Within seasonal home ranges, the owls concentrated their activity in several core areas, frequently moving back and forth among preferred areas. The owls consistently shifted seasonal ranges, concentrating activity at higher elevations during summer months. Despite this shift to higher elevations during breeding, nest sites were all within the lower one third of the study area and were generally on the periphery of the home range. Although not conclusive, our data suggested that the owls used larger home ranges and moved further from one day to the next during a period of declining prey.

As indicated by other authors, we found no evidence of defense of foraging areas. Home ranges of owls overlapped extensively and male boreal owls were found roosting within 200 m of one another. A mixed pattern of sedentary and nomadic behavior was indicated by year to year movements.

ACKNOWLEDGEMENTS

L. Flaccus and A. Wright helped radiotrack owls. The U.S. Forest Service, Forest and Range Sciences Laboratory, Boise, Idaho, and Idaho Department of Fish and Game provided major funding. The N.A. Bluebird Society, U.S. Army, Max McGraw Wildlife Foundation, U.S. Forest Service Region I, Columbia Basin Audubon Society, TDK Electronics Corp., and Duracell Corp. also gave support. Payette National Forest provided housing. The study could not have been completed without the support of all the above individuals and organizations.

LITERATURE CITED

- Andersson, M. 1980. Nomadism and site tenacity as alternative reproductive tactics in birds. *Journal of Animal Ecology* 49:175-184.
- Bondrup-Nielsen, S. 1978. Vocalizations, nesting, and habitat preferences of the boreal owl (*Aegolius funereus*) in North America. Masters Thesis. Univ. of Toronto. 151 pp.
- Burt, W. H. 1943. Territoriality and home range concepts as applied to mammals. *Journal of Mammalogy* 24:346-352.
- Catling, P.M. 1972. A study of boreal owl in southern Ontario with particular reference to the irruption of 1968-69. *Canadian Field Naturalist* 86:223-232.
- Dixon, K. R. and J. A. Chapman. 1980. Harmonic mean measure of animal activity areas. *Ecology* 61:1040-1044.
- Forbes, J. E. and D. W. Warner. 1974. Behavior of a radio tagged saw-whet owl. *Auk* 91:783-794.
- Forsman, R. D., E. C. Meslow and H. M. Wight. 1984. Distribution and biology of the spotted owl in Oregon. *Wildlife Monographs* 87:1-64.
- Hayward, G. D. (in review). A method for study of owl foraging habitat and behavior. *Raptor Research*.
- Hayward, G. D. and E. O. Garton. 1983. First nesting record for boreal owl in Idaho. *Condor* 85:501.
- Hurlbert, S. H. 1984. Pseudoreplication and the design of ecological field experiments. *Ecological Monographs* 54:187-211.
- Jacobsen, B. V. and G. A. Sonerud. (these proceedings). Calculating the home-range size of Tengmalm's Owl: a comparison of two methods. Northern Forest Owl Symposium. Winnipeg, Manitoba, Canada, February 3-7, 1987.
- Jennrich, R. I. and F. B. Turner. 1969. Measurements of noncircular home range. *Journal of Theoretical Biology* 22:227-237.
- Korpimäki, E. 1986. Gradients in population fluctuations of Tengmalm's owl *Aegolius funereus* in Europe. *Oecologia* 69:195-201.
- Lofgren, O., B. Hornfeldt, and B. G. Carlsson. 1986. Site tenacity and nomadism in Tengmalm's owl (*Aegolius funereus*) in relation to cyclic food production. *Oecologia* 69:321-326.
- Lundberg, A. 1979. Residency, migration and a compromise: Adaptations to nest site scarcity and food specialization in three Fennoscandian owl species. *Oecologia* 41:273-281.
- Mikkola, M. 1983. The owls of Europe. Buteo Books, Vermillion, SD. 397 pp.
- Palmer, D. A. 1986. Habitat selection, movements and activity of boreal and saw-whet owls. Masters Thesis. Colo. State Univ. Ft. Collins. pp. 38-68.
- Samuel, M. D. and E. O. Garton. 1985. Home range: A weighted normal estimate and tests of underlying assumptions. *Journal of Wildlife Management* 49: 513-519.
- Samuel, M. D., D. J. Pierce, E. O. Garton, L. J. Nelson, and K. R. Dixon. 1985. User's manual for program HOME RANGE. Univ. of Idaho, Forest, Wildlife and Range Experiment Station Tech. Rep. 15. 70 pp.
- Schoener, T. W. 1981. An empirically based estimate of home range. *Theoretical Population Biology* 20:281-325.
- Smith, D. G. and R. Gilbert. 1984. Eastern screech owl home range and use of suburban habitats in southern Connecticut. *Journal of Field Ornithology* 55:322-329.
- Solheim, R. 1983. Bigyny and biandry in the Tengmalm's owl *Aegolius funereus*. *Ornis Scandinavica* 14:51-57.
- von Haartman, L. 1968. The evolution of resident versus migratory habit in birds. *Ornis Fennica* 45:1-7.
- Wallin, K. and M. Andersson. 1981. Adult nomadism in Tengmalm's Owl *Aegolius funereus*. *Ornis Scandinavica* 12:125-126.

Occurrence of the Boreal Owl in Northeastern Washington¹

M. W. O'Connell²

Abstract. Until its first documented nesting south of Canada in Minnesota in 1978, the Boreal owl was considered to occur only as an accidental in the United States. Since that time, the species has been found elsewhere in the United States (Colorado and Idaho). With the knowledge of the bird's habitat preference, a search was made for the location of habitat and then the birds. Maps showing all Engelmann spruce (*Picea engelmanni*), Subalpine fir (*Abies lasiocarpa*) timber types were used to define potential Boreal owl habitat. During parts of 1985 and 1986, Boreal owls were found during all seasons of the year. Although a nest was not located, one juvenile bird was found.

INTRODUCTION

Heretofore only three documented sightings of Boreal owl (*Aegolius funereus*) existed for the state of Washington. The first bird was collected in January 1905 in Whatcom County, Western Washington, but as Johson & Hudson (1976, *Auk* 93: 195-196) pointed out it unfortunately soon disappeared resulting in questionable identity. A second specimen was obtained on January 10, 1974 in Pullman, Whitman County, Eastern Washington by Richard E. Johnson (Batey, et al, 1980). In May and June of 1979 a pair and eventually two or three fledglings were observed in a back yard in Pullman, Washington (Batey, et al, 1980).

Although fledged Boreal Owl juveniles were seen in Colorado in 1963 (Baldwin & Koplín, 1966) and in Montana in 1973 (Skaar, 1975), it wasn't until 1978 that the first documented nesting of the Boreal Owl occurred south of Canada; in Cook County, Minnesota (Eckert & Savaloya, 1979). This did not extend the established breeding range (A.O.U. 1957), because the observation was made so close to the Canadian border. However, two subsequent nesting records did extend that range. Hayward & Garton's (1983) observations demonstrated that a resident population is established in the mountains of Central Idaho. They concluded that the presence of this resident population of Boreal Owls supported Baldwin & Koplín's (1966) hypothesis that the breeding range of this species extends southward along the Continental Divide. To further substantiate

this hypothesis, Palmer & Ryder (1984), found nesting Boreal Owls observed or heard throughout the Rocky Mountain Region (Colorado, Wyoming, Montana, Idaho and Washington). Knowing this and the fact that the Kettle River Range and the Selkirk Mountains of northeastern Washington are "foothills" of the Rocky Mountains and a part of the Rocky Mountain Region, my associate Bart Whelton and I thought it possible that the Boreal Owl might be found here as a permanent resident.

STUDY AREA

The Selkirk Mountains of northeastern Washington are characterized by many peaks over 1500 meters in elevation with some exceeding 2100 meters. Much of the area over 1500 meters



Figure 1.--Spruce-fir forest along the Colville-Kaniksu divide.

¹"Paper presented at the symposium, Biology and Conservation of Northern Forest Owls, Feb. 3-7, 1987, Winnipeg, Manitoba. USDA Forest Service General Technical Report RM-142."

²M.W. "Bill" O'Connell is a Consulting Forester specializing in Wildlife, Kettle Falls, Washington.

is covered with a forest of climax spruce-fir (*Picea engelmanni*-*Abies lasiocarpa*) similar to that found in the areas searched by Palmer & Ryder. This spruce-fir forest is a boreal forest type very similar to that of northwestern Canada with the major difference being that the Engelmann spruce is replaced by Black Spruce (*Picea mariana*) and White Spruce (*Picea glauca*). The spruce-fir stands usually have a crown closure of less than 70% interspersed with small



Figure 2.--Boreal Owl habitat in the Selkirk Mountains of the Colville National Forest.

openings and larger mountain meadows. This is the forest type which Boreal Owls apparently prefer (Palmer & Ryder, 1984).

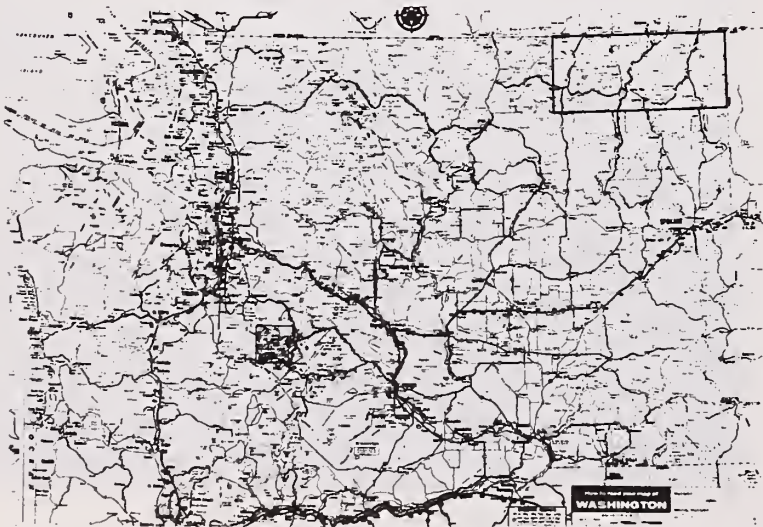

Figure 3.--Map of Washington state with the study area outlined.

In northeastern Washington both the Kettle River range and the Selkirk Mountains are located within the confines of the Colville National Forest. I visited the Forest Supervisors office where I studied their timber type maps and transferred the Engelmann spruce and Alpine Fir types onto a copy of the Colville National Forest map. A timber type is one named for its major volume species regardless of tree size, however, it may and in these types most often does, contain other species. Our field investigations began in late April of 1985 and continued periodically throughout 1985. Since this effort was a spare-time project, it was conducted whenever possible usually on weekends. A tape of the winnowing call (Bondrup-Nielson, 1984) was played in or near the appropriate habitat, usually at one quarter mile intervals, during the nighttime hours. The first response was obtained in Sherman Pass on the night of April 27 from a male giving the winnowing call. When we continued playing the call the bird approached and lit on a nearby tree. Each of the responses obtained at later dates were defensive in nature; either the SKIEW call or the OO-WORK call. When emitting these defensive responses the birds were very close to us (30-35 meters) and at times flew directly in our faces or over our heads. Whether they came some distance before giving the call or we just did not hear them until they were close by, we are not sure. It is my opinion that they were on territory when we approached them with the call and consequently they responded from wherever they were upon hearing our recording. A very small part of the existing habitat was searched because of difficult access and limited time.

Nevertheless, of 5 different sites composed of the spruce-fir habitat that were visited on one or more occasions between April 27 and December 15, 1985, Boreal Owls were found at each site on at least one occasion. At one site (Salmo Pass) the birds were located in the same locality in three different months (June, July and September). In all but one instance the birds were found at over 1580 meters elevation. The owls that were found below 1580 meters were located in December and were occupying a forest composed largely of lodgepole pine (*Pinus contorta*) with a mixture of the typical spruce-fir. This was a very cold site adjacent to the meadows on the banks of the Little Pend Oreille River.

DISCUSSION

Though we did not find nests, we did find Boreal Owls in northeastern Washington in their favored habitat during all seasons of the year. This suggests that Boreal Owls are permanent residents, in the proper habitat, in northeastern Washington. High densities occur in at least some areas; we found 12-15 birds in one area. We learned that Boreal Owls will respond to a tape of the winnowing call during most of the year. Also, we found that they were easier to locate on moonlit nights because they often approached without making a sound

Table 1. Boreal Owl record Northeastern Washington - 1985

Date	Location	Approximate Elevation	County	No. Owls	Source
27 April	Sherman Pass	1570m.	Ferry	1 seen	Bill O'Connell Bill & Geness Riechert Bart Whelton
29 April	Sherman Pass	1700m.	Ferry	2 seen	Bill O'Connell
4 May	Sherman Pass	1570m.	Ferry	0	Bart Whelton
31 May	Sherman Pass	1570m.	Ferry	0	Bart Whelton
25 June	Salmo Pass	1845m.	Pend Oreille	1 heard	Bart Whelton
1 July	Pass Cr. Pass	1645m.	Pend Oreille	0	Bart Whelton
2 July	Pass Cr. Pass	1645m.	Pend Oreille	0	Bill O'Connell Bart Whelton
3 July	Salmo Pass	1845m.	Pend Oreille	1 heard	Bart Whelton
4 July	Salmo Pass	1845m.	Pend Oreille	0	Bart Whelton
17 July	Sherman Pass	1700m.	Ferry	0	Bill O'Connell Bart Whelton
18 July	Monumental Mtn.	1580m.	Pend Oreille	0	Bill O'Connell Bart Whelton
1 Sept.	Monumental Mtn.	1580m.	Pend Oreille	1 seen	Bill O'Connell Bart Whelton
19 Sept.	Salmo Pass	1845m.	Pend Oreille	2 (1 juvenile)	Bart Whelton
28 Sept.	Colville-Kaniksu Divide	1650 to 1900m.	Pend Oreille	12 seen	Bill O'Connell Bart Whelton
19 Oct.	Kettle Crest	-----	Ferry	1 heard	Bill O'Connell Bart Whelton
15 Dec.	Tiger Highway Clark Cr. Rd.	1067m.	Stevens	3 heard	Bill O'Connell Bart Whelton

and therefore we had to depend on visual location entirely. By learning the various calls of the Boreal Owl it is possible to search for it over most of the year. Physical access to its habitat is the greatest hinderance.

Our records (Table 1) seem to support the theory advanced by Baldwin & Koplín (1966) and substantiated by Palmer & Ryder (1984) that "a contiguous breeding range extends in the Rocky Mountains from Canada south to Colorado."

Since our work by necessity was accomplished on a spare-time basis, I recommend surveys that cover a greater percentage of existing habitat both in northeastern Washington

and in spruce-fir habitats of the Cascade Mountains of Washington and Oregon. The Blue Mountains of northeastern Oregon also contain spruce-fir habitats and are also worthy of consideration.

LITERATURE CITED

- Baldwin, P.H., and J.R. Koplín, 1966. The Boreal Owl as a Pliocene relict in Colorado. *Condor* 68:299-300.

- Batey, K.M., H.H. Batey, and I.U. Buss, 1980. First Boreal Owl fledglings for Washington state. *Murrelet* 61:80.
- Bondrup-Nielson, S. 1984. Vocalizations of the Boreal Owl (*Aegolius funereus richardsoni*) in North America. *Canadian Field-Naturalist* 98 (2):191-197.
- Eckart, K.R., and T.L. Savaloya. 1979. First documented nesting of the Boreal Owl south of Canada. *Am. Birds* 33:135-137.
- Hayward, G.D., and E.O. Garton. 1983. First nesting record for Boreal Owl in Idaho. *Condor* 85:501.
- Johnson, R.E., and G.E. Hudson. 1976. A Washington Record of the Boreal Owl. *Auk* 93:195-196.
- Palmer, D.A., and R.A. Ryder. 1984. The first documented breeding of the Boreal Owl in Colorado. *The Condor* 86:215-217.
- Skaar, P.D. 1975. Montana bird distribution. Privately published, Bozeman, Montana.

Home Range of Tengmalm's Owl: A Comparison Between Nocturnal Hunting and Diurnal Roosting¹

Bjørn V. Jacobsen and Geir A. Sonerud²

Abstract.--Three nesting Tengmalm's Owl males equipped with radio transmitters during a microtine rodent peak year (1985) in the northern boreal zone of southeast Norway were tracked during their nocturnal hunting, and located at their diurnal roosts, for 1-2 months. Home range sizes calculated by the convex polygon method were larger for nocturnal hunting than for diurnal roosting. The overlap between these two types of home ranges was small.

INTRODUCTION

The nocturnal behavior of owls is inherently difficult to study except in areas with continuous daylight in summer. The introduction of radio telemetry has made it possible to sample data on the activity of animals without seeing them, and to follow them continuously over large areas and long periods of time. Some of the first studies making use of radio telemetry dealt with owls (Nicholls and Warner 1972, Forbes and Warner 1974).

Tengmalm's Owls *Aegolius funereus* usually search for prey during night and roost during day (Glutz von Blotzheim and Bauer 1980). So far, their home range sizes have been calculated by either locating the owls during their diurnal roosting (Bondrup-Nielsen 1978) or by tracking the owls during their nocturnal hunting activity (Sonerud et al. 1986). However, since their habitat selection during diurnal roosting (Bondrup-Nielsen 1978, Hayward and Garton 1984) and nocturnal hunting (Sonerud et al. 1986) often differ (B.V. Jacobsen and G.A. Sonerud, unpubl.), size and shape of their home ranges calculated from diurnal roosting and nocturnal hunting may also differ. In this paper we compare these two types of home ranges by using data from three radio-equipped nesting males of Tengmalm's Owl that were tracked both during diurnal roosting and nocturnal hunting.

¹Paper presented at the symposium, Biology and Conservation of Northern Forest Owls, Feb. 3-7, 1987, Winnipeg, Manitoba. USDA Forest Service General Technical Report RM-142.

²Bjørn V. Jacobsen is Graduate Student and Geir A. Sonerud is Research Associate, Department of Biology, Division of Zoology, University of Oslo, Oslo, Norway.

STUDY AREA

The study was performed during April-July 1985 within an area of 20 km² at an altitude of 480-620 m in the northern boreal zone (sensu Anonymous 1977) in Hedmark County, southeast Norway (60°55'N, 11°19'E). The study area is fairly flat and consists of Norway Spruce *Picea abies* forest with a few scattered cultivated fields. Deciduous trees, mainly birch *Betula* spp., occur sparsely. The forest structure is greatly modified by modern silviculture introduced during the last two decades, resulting in a mosaic of mostly clear-cuts and mature stands.

The study area is usually snow-covered until mid-May. In 1985 the snow-melt took place extremely late. The ground was completely snow-covered until May 8, and partly snow-covered until June 1. The snow disappeared first in the clear-cuts, and last in mature spruce forest (cf. Sonerud 1986). By May 25 the clear-cuts were completely snow-free, while snow still covered approximately half the area in mature spruce forest.

The microtine rodent prey population (e.g. Glutz von Blotzheim and Bauer 1980, Sonerud 1986) was at a peak from summer 1984 until spring 1985 (G.A. Sonerud, unpubl.)

METHODS

Three males of Tengmalm's Owl were caught in mist-net at the nest site during the nights of April 11, May 8 and June 3 1985. They were equipped with radio-transmitters (model Televilt TK-142-2S (male 1) and Biotrack SS-1), and released the same night. The three owls will be referred to as M1, M2 and M3, respectively. M1 got his transmitter replaced with a new one (same model) during the night of May 28.

The three owls were tracked during their nocturnal activity for a total of 124 hours, and 59 diurnal roosts were located (table 1). The owls were never found roosting in the same tree twice or more. The nocturnal tracking was done by skiing (until May 20) or walking, cross-triangulating with a portable receiver (model Televilt RX-81) and a hand-held 4-element yagi-antenna at distances as close as possible, trying to keep in contact with the bird as continuously as possible. Tengmalm's Owls search for prey by a sit-and-wait tactic characterized by brief perchings at low heights, and do not seem to be disturbed by the observer's activity (Norberg 1970, Sonerud 1980).

When tracking the owls, locations of cross-triangulations as well as direct observations were plotted on copies of aerial photos with scale 1:15,000. Later these locations were plotted on a map with scale 1:5,000. Home range sizes were calculated for nocturnal hunting and diurnal roosting separately by the convex polygon method, i.e. the area described by connecting only the outermost locations which make a convex polygon (Mohr 1947). Both cumulative and total home range sizes were calculated.

For each owl the size and spatial distribution of the home range obtained from the nocturnal and diurnal locations were compared by calculating their overlap (O) as

$$O = \frac{2(A \cap B)}{A + B},$$

where A denotes the nocturnal home range, and B the diurnal home range, while $A \cap B$ denotes the area common to A and B (Sonerud et al. 1986).

RESULTS

The sizes of the nocturnal home ranges for the three males varied from 131 ha - 227 ha with an average of 181 ha (SD=48) (table 1). The home range sizes based on diurnal roosts varied from 94 ha - 226 ha with an average of 142 ha (SD=73) (table 1).

Table 1.--Size of and overlap between home ranges of nesting male Tengmalm's Owls based on nocturnal hunting and diurnal roosting, with number of nights (and hours) tracking the hunting owls, and number of days localizing the roosting owls. For calculation of overlap see the text.

Owl	Home-range size (ha)			Tracking effort	
	Nocturnal	Diurnal	Overlap	Nights (hours)	Days
M1	227	226	0.62	10 (54)	29
M2	184	94	0.46	13 (59)	21
M3	131	106	0.61	4 (11)	9

The overlap between the home range based on nocturnal activity and that based on diurnal roosting (fig. 1) varied from 0.46-0.62 with an average of 0.56 (SD=0.09) (table 1). For all owls the nocturnal home range was larger than the diurnal one, but the sample size is too small for statistical testing (table 1).

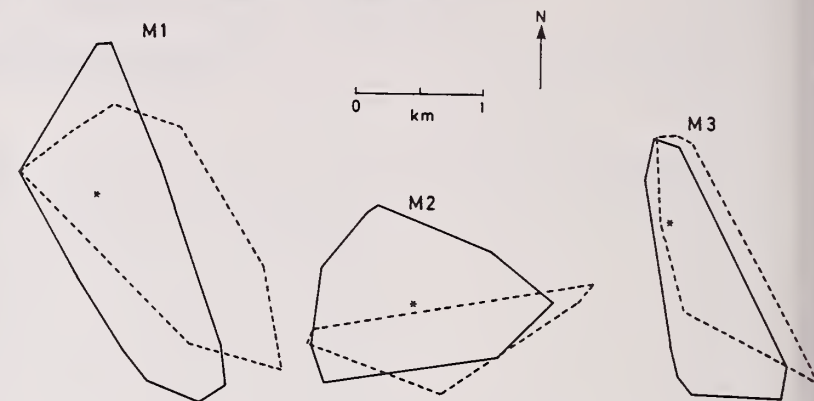

Figure 1.--Size and spacing of home ranges based on tracking the nocturnal activity (solid line) and locating the diurnal roosts (broken line) of three nesting males of Tengmalm's Owl, as calculated by the convex polygon method. Positions of nests indicated by asterices.

For M1 the cumulative size of both the nocturnal and diurnal calculated home range levelled off (figs. 2 and 3), thus indicating that the total sizes calculated were the real home range sizes of this owl. For M2 the cumulative size of the diurnal home range levelled off (fig. 3), while that of the nocturnal home range did not (fig. 2). Thus we probably have underestimated the real nocturnal home range size, but possibly have correctly estimated the diurnal home range size, of this owl. For M3 neither of the cumulative sizes levelled off during our study (figs. 2 and 3), indicating that both the nocturnal and the diurnal home range sizes calculated are underestimations of the real home range sizes of this owl.

DISCUSSION

Reliability of the calculated home range sizes

The cumulative size of the nocturnal home range levelled off for one male (10 nights of tracking), but not for the two others (4 and 13 nights). Sonerud et al. (1986) suggested that more than five nights of tracking are needed to reveal the actual nocturnal home range size of a nesting male Tengmalm's Owl. Our data indicate that even more than 13 nights may be needed. Similarly, the cumulative home range size of 3 Eastern Screech Owls *Otus asio* in Connecticut, USA, continued to increase throughout the time monitored (Smith and Gilbert 1984).

The cumulative size of the home range based on diurnal roosts levelled off for two males (21 and 29 days of locating), but not for the third (9 days). Therefore, in order to obtain the

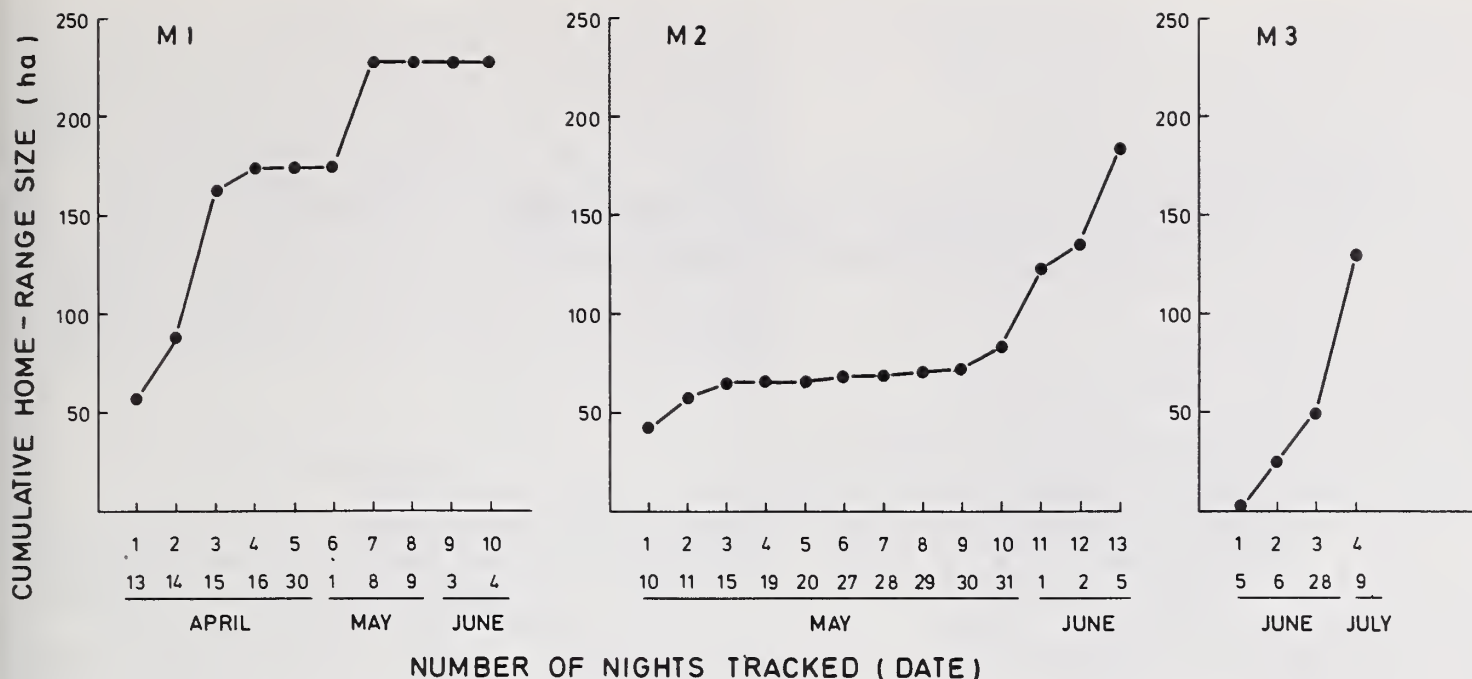
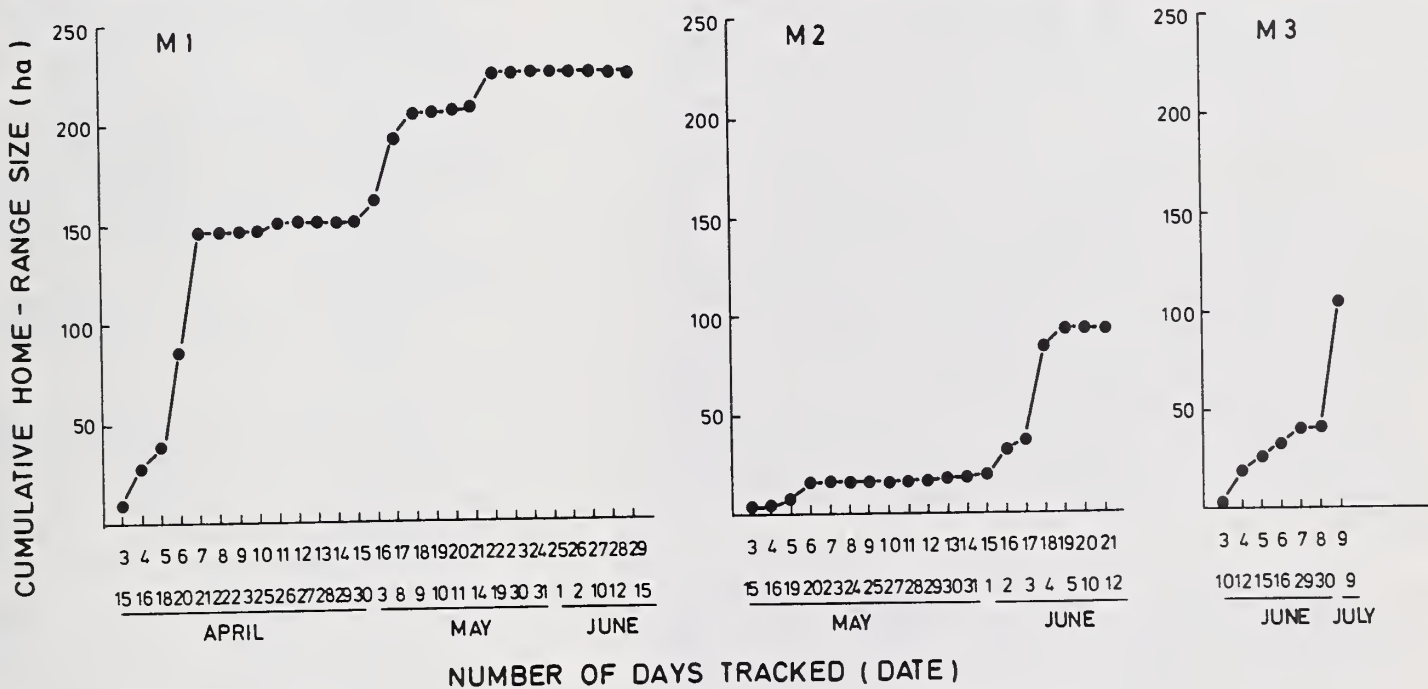

Figure 2.--Cumulative size of nocturnal home range in relation to number of nights tracking for three nesting males of Tengmalm's Owl, as calculated by the convex polygon method. Dates of days succeeding the tracking nights are shown.

Figure 3.--Cumulative size of diurnal home range in relation to number of days locating the diurnal roost for three nesting males of Tengmalm's Owl, as calculated by the convex polygon method. Dates of days locating are shown.



real diurnal home range size, the diurnal roost should probably be located on at least 10 days, but not necessarily more than 20.

Home range size in relation to ecological factors

We know of only one former study of nocturnal home range size in the Tengmalm's Owl. A male tracked for five nights in an area neighbouring our study area had a recorded home range size of 205 ha (Sonerud et al. 1986). This is within the range found in our study, but is rather large when the few nights of tracking are corrected for. The rather large home range may have been caused by the lower prey availability in the study of Sonerud et al. (1986) than in our study. In Canada three nesting males of the sub-

species Boreal Owl *Aegolius f. richardsoni* were found to have home ranges of 100 ha, 250 ha and 500 ha, calculated from the locations of their diurnal roosts only (Bondrup-Nielsen 1978). A male of the related Saw-whet Owl *Aegolius acadicus* studied over twenty days in late autumn in Minnesota, USA, had a home-range of 227 ha, as calculated by the convex polygon method from data in Forbes and Warner (1974).

The availability of prey for Tengmalm's Owls in clear-cuts strongly increases from snow-covered to snow-free ground in spring (Sonerud 1986), while it decreases during summer due to growth of field vegetation (Sonerud et al. 1986). M2 spent almost all his hunting effort in the large clear-cut surrounding his nest during snow-melt and the first week after the snow had

disappeared in the clear-cut. Both nocturnal and diurnal cumulative home range size levelled off during this period. By the end of May when the early growth of field vegetation had made prey less available in the clear-cut, M2 started spending more time hunting in the mature spruce forest stands, and the size of the home range increased. However, this increase also coincided with the female's resuming of hunting after incubation and brooding. Therefore, both lowered prey availability in the clear-cut as well as avoidance of overlap with the female's hunting area may explain the increase of the home-range size. The small home range size of M2 at the time when the female resumed hunting was due to the clear-cut being a core area (cf. Samuel et al. 1985), with a high availability of prey during snow-melt. For M1, the home range did not include any such high prey availability core area, and had thus reached its final size by the time the female resumed hunting. Therefore, no further increase occurred when both mates exploited the home range.

Nocturnal and diurnal home ranges: Which should be measured?

For all three males there was a relatively small overlap between the nocturnal and the diurnal home range. This was independent of the number of nights the owls were tracked and the number of roosts located. The overlap was smaller for M2 than for the two others. M2 nested in a box situated in a 20 ha clear-cut (see description in Sonerud (1986)), and his home range included few middle-aged stands of Norway spruce, which we found the Tengmalm's Owl to prefer as roosting habitat (B.V. Jacobsen and G.A. Sonerud, unpubl.). This may explain why the home range based on diurnal roosts, and hence why the overlap between the nocturnal and diurnal home range, were so small for this male. For the two other males, the middle-aged stands preferred for roosting were more common throughout the home range.

Smith et al. (1981) found that the diurnal home ranges of coyotes Canis latrans in general were included in the nocturnal home ranges. This would also have been the case in the Tengmalm's Owl if we had tracked the males until they roosted each night, and not located their roosts separately. However, in our study several roosts were located at days when the owl had not been tracked the night before. This explains why the diurnal home range is not included in the nocturnal home range for any of the three males. Hence, we conclude that tracking the owls during their nocturnal hunting until they have roosted will be sufficient to give a reliable estimate of the real home range size, while home range sizes based on diurnal roosts only will be underestimations of the real ones.

ACKNOWLEDGEMENTS

We thank B.T. Bækken for assistance during

the field work, and the land owner A. Solberg for kindly allowing us to use the study area and for providing free accommodation. We also thank B. Danielson for comments on the manuscript, M.Aas for typing, and E. Kresse for drawing the figures. The radio-tracking equipment was financed by grants to G.A. Sonerud from the University of Oslo, the Norwegian Research Council for Science and the Humanities (NAVF), and the Nansen Foundation. The field work was supported by grants to B.V. Jacobsen from the Robert Collett legacy.

LITERATURE CITED

- Anonymous. 1977. Naturgeografisk regioninndeling av Norden. Nordiske Utredninger, B 34: 1-137. (In Danish, Norwegian and Swedish with summaries in English and Finnish).
- Bondrup-Nielsen, S. 1978. Vocalizations, nesting and habitat preferences of the Boreal Owl (Aegolius funereus) in North America. M. Sc. thesis, University of Toronto.
- Forbes, J.F., and D.W. Warner. 1974. Behavior of a radio-tagged Saw-whet owl. Auk 91: 783-795.
- Glutz von Blotzheim, U.N., and K.M. Bauer. 1980. Handbuch der Vögel Mitteleuropas, Vol. 9. Akademische Verlagsgesellschaft, Wiesbaden.
- Hayward, G.D., and E.O. Garton. 1984. Roost habitat selection by three small forest owls. Wilson Bulletin 96: 690-692.
- Mohr, C.O. 1947. Table of equivalent populations of North American small mammals. American Midland Naturalist 37: 223-249.
- Nicholls, T.H., and D.W. Warner. 1972. Barred Owl habitat use as determined by radiotelemetry. Journal of Wildlife Management 36: 213-224.
- Norberg, R.A. 1970. Hunting technique of Tengmalm's Owl Aegolius funereus (L.). Ornis Scandinavica 1: 51-64.
- Samuel, M.D., D.J. Pierce, and E.O. Garton. 1985. Identifying areas of concentrated use within the home range. Journal of Animal Ecology 54: 711-719.
- Smith, D.G., and R. Gilbert. 1984. Eastern Screech-Owl home range and use of suburban habitats in southern Connecticut. Journal of Field Ornithology 55: 322-329.
- Smith, G.J., J.R. Cary, and O.J. Rongstad. 1981. Sampling strategies for radio-tracking coyotes. Wildlife Society Bulletin 9: 88-93.
- Sonerud, G.A. 1980. Jaktstrategier hos flyvende småpattedyr-predatorer i barskog. Cand. real. thesis, University of Oslo. (In Norwegian).
- Sonerud, G.A. 1986. Effect of snow cover on seasonal changes in diet, habitat, and regional distribution of raptors that prey on small mammals in boreal zones of Fennoscandia. Holarctic Ecology 9: 33-47.
- Sonerud, G.A., R. Solheim, and B.V. Jacobsen. 1986. Home-range use and habitat selection during hunting in a male Tengmalm's Owl Aegolius funereus. Fauna Norvegica, Ser. C, Cinclus 9: 100-106.

The Breeding Biology of Northern Saw-Whet Owls in Southern British Columbia¹

Richard J. Cannings²

Abstract.-- A study of 12 Northern Saw-whet Owl nests over three years in two distinct habitats yielded data on nesting chronology, clutch size, nestling growth, nesting success and prey selection. Radio telemetry data provided information on the movements of three males and two fledglings.

INTRODUCTION

The Northern Saw-whet Owl (*Aegolius acadicus*) is a relatively common and widespread owl, breeding across North America from central Canada south to central United States (Godfrey 1986). Despite its extensive range throughout populated North America, little is known of its breeding biology. I became interested in saw-whets in 1984 when I found three nests in 30 nest-boxes put up for Flammulated Owls in the Okanagan Valley of south-central British Columbia (fig. 1). That winter I put up over 150

nest-boxes hoping to attract a proportionate number of owls, but the boxes still held only three pairs of saw-whets in both 1985 and 1986. In 1986 I also found two nests in natural cavities.

Northern Saw-whet Owls breed in two distinct habitats in the Okanagan Valley: montane coniferous forests and riparian deciduous woodlands. In the montane coniferous forests, by far the most abundant habitat in the region, they are found up to 1400 m elevation, but are commonest from 500 to 1000 m where ponderosa pine (*Pinus ponderosa*) and Douglas-fir (*Pseudotsuga menziesii*) predominate (hereafter called the "pine-fir forest"). Saw-whets are occasionally seen above 1500 m elevation, but seem to be replaced as a breeding species above this altitude by the larger Boreal Owl (*Aegolius funereus*). The deciduous woodlands are characterized by stands of water birch (*Betula occidentalis*) along old oxbows of the Okanagan River, surrounded by wet meadows and pastureland at 280 m elevation. This habitat is very restricted in the Okanagan Valley, with an area of less than 1000 ha. One focus of my study was to compare the breeding ecology of saw-whets in these two different habitats, but the work was initiated primarily to gather some basic breeding biology data on this species.

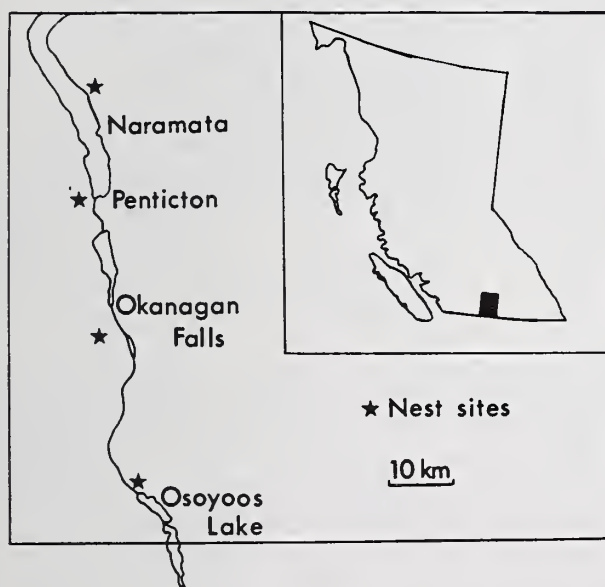

Figure 1.--Okanagan Valley study area; inset shows position in British Columbia.

STUDY AREA AND METHODS

I was unable to find any nests in pine-fir forests in 1985, when I concentrated my efforts in monitoring 100 nest-boxes in a 4200 by 600 m grid near Naramata, northeast of Penticton. In 1986, therefore, I looked throughout the south Okanagan area for singing males in March and April and concentrated nest searches around the birds I found. That year I succeeded in finding two nests in this habitat, both in natural cavities (fig. 1, Penticton and Okanagan Falls sites). The road survey for singing males also provided a rough measure of the relative population densities of saw-whets in the two habitats.

¹Paper presented at the symposium, Biology and Conservation of Northern Forest Owls, February 3-7, 1987, Winnipeg, Manitoba. USDA Forest Service General Technical Report RM-142.

²Richard J. Cannings is Assistant Curator of the Cowan Vertebrate Museum, Department of Zoology, University of British Columbia, Vancouver, B. C.

I had better luck with finding nests in the more restricted deciduous woodland habitat. In January 1985 I essentially filled the available habitat (about 65 ha of woodland) in the 235-ha Osoyoos Oxbows Wildlife Reserve with 63 nest-boxes in addition to the 10 Wood Duck boxes already there. Three pairs used these boxes in both 1985 and 1986; I found no nests in natural cavities in this habitat.

I visited nests every two to three days, except during incubation when visits were less frequent. I weighed nestlings to the nearest gram with a Pesola spring scale and measured their wing chord, culmen, head, tail, and tibiotarsus length with dial calipers.

Whole or half-eaten prey were commonly found in nests from the egg-laying period through the early nestling period. I identified, sexed, and measured all prey remains at each visit. As the nestlings grew, fewer uneaten prey items were found in nests, and the brooding females kept the nests free of pellets and droppings. When the youngest nestling was about 15 to 18 days old, however, the females stopped brooding the young and a considerable quantity of pellets and other prey remains built up in the nests. After the young left the nests, I removed and examined the nest material for these prey remains. Small mammal prey from this material were generally identified by examining the lower jaws, since the skulls were destroyed in most cases.

I trapped and banded all eight adult females and most (8 of 10) adult males, measured them, and marked their facial disks with waterproof ink for individual recognition. In addition, I put a colored plastic jess on all birds in 1985 and on three adult females in 1986, but two of the six females removed the jess quickly so I stopped the practice. I trapped adult females on their nests and mist-netted adult males in front of the nests; I also noosed two unpaired males on their day-roosts.

To get an estimate of prey density and diversity, I trapped small mammals in two different ways. In 1985 I live-trapped and marked mice in Longworth traps set 10 m apart in grids at the Osoyoos site (39 traps, 6 nights) and at the Naramata site (100 traps, 3 nights). In 1986 I snap-trapped small mammals once a month from March through June (50 traps set 5 m apart in a line through representative habitats) at the Penticton and Osoyoos sites.

Late in the 1986 breeding season, I was able to attach 3-gm radio transmitters (Lotek Engineering, Aurora, Ontario) to two breeding males (feeding nestlings and fledglings; one each at Penticton and Osoyoos), one non-breeding male, and two fledglings (one each at Penticton and Osoyoos) to monitor their movements and locate roosting sites. I tracked these birds by following them on foot with a hand-held, two-element yagi antenna and portable receiver, and calculated home ranges by the convex polygon method.

RESULTS

Population Densities

In 1986, 21 singing male saw-whets were heard on 104 km of surveys through the pine-fir forests (0.2/km), while 5 were heard on 10 km of surveys through the deciduous woodland habitat (0.5/km). This indicates that the Northern Saw-whet Owl population in the deciduous woodland may be about 2.5 times as dense than that in the pine-fir forest, although this figure is obviously imprecise.

Nest Sites

Of twelve nests found in this study, ten were in nest-boxes. Eight of the nest-boxes were approximately 43 x 18 x 18 cm, one was approximately 60 x 25 x 25 cm, and the last was 30 x 15 x 15 cm in size. These boxes were nailed to tree trunks from 2.6 to 6.1 m above the ground. The two natural sites were in Northern Flicker (*Colaptes auratus*) holes in old ponderosa pine snags 2.8 and 4.6 m above the ground. Nearest neighbour distances between nests at the Osoyoos site ranged from 0.8 to 1.4 km (mean 1.1 km, n=4).

Site Fidelity

In 1985, all the females and two of the males from the three nesting pairs were banded at Osoyoos, as well as an unpaired male and all of the fledglings. In 1986, three pairs at least attempted to breed on the area, as well as another unpaired male. None of the females were the same as the previous year, and at least two of the breeding males were new. The third breeding male and the unpaired male were not caught in 1986, but I could not see bands on their legs despite close views. From this small sample, it would seem that Northern Saw-whet Owls are not strongly philopatric. Interestingly, one of the 1986 pairs nested in the same box (out of 25+ to choose from on their territory) in which a totally different pair nested in 1985.

Nesting Phenology

Northern Saw-whet Owls begin nesting in the Okanagan Valley in March. Nine clutch initiation dates ranged from 1 to 31 March, with a mean of 12 March. The exact timing of clutch initiation may be weather-related; the earliest nest at Osoyoos was started 12 days earlier in 1986, when there was a sudden amelioration of daily mean temperature in late February, than in 1985, when the amelioration was more gradual. Comparisons between the two habitats can only be made for 1986, when clutches were initiated at Osoyoos (280 m el.) on 1 and 5 March, while clutches at Penticton (550 m) and Okanagan Falls (615 m) were initiated on 8 and 21 March respectively.

One 1984 nest at Naramata begun about 16 May was probably a second clutch, especially considering that a second nest about 1 km away (perhaps belonging to the same female?) fledged its last young on 17 May.

The earliest nest, begun on 1 March 1986 at Osoyoos and containing a full clutch of five eggs on 10 March, was abandoned on the latter date due to disturbance at the nest. Two days later the same female began laying a replacement clutch in a nest-box 270 m away and completed another clutch of five eggs, thus laying 10 eggs in a 21-day period. Laying, hatching and fledging intervals and incubation and nestling periods are summarized in table 1.

Incubation may sometimes begin with the second egg laid, since the two instances of an incubation period (calculated from the day an egg was laid) greater than 27 days both concerned the first young to hatch in a nest.

Table 1.--Nesting intervals and periods. Sample sizes are for individual eggs or nestlings.

	n	Range (days)	Mean
Laying Interval	7		2.0
Incubation Period	9	27-29	27.3
Hatching Interval	19		1.7
Nestling Period	12	29-36	33.4
Fledging Interval	9		1.4

Clutch Size and Nesting Success

The clutch size of nine nests ranged from five to seven, with a mean of 5.9 eggs and a mode of six (four nests). This value is somewhat larger than those given in Murray (1976).

Excluding two nests which were almost certainly abandoned due to human disturbance, I could calculate nesting success parameters from seven nests, summarized in table 2. Hatching failures were due to infertile eggs or the death of embryos in eggs; no nests (other than the two mentioned above) were abandoned or predated in the egg stage. Interestingly, the two cases of major hatching failure (five of six and three of five eggs failing) involved the probable second clutch and the definite replacement clutch (see above).

The causes of nestling deaths were harder to determine. Four nestlings in one brood of six died within two days of hatching, apparently from an infestation of *Carnus hemapterus*, a small blood-sucking, parasitic wingless fly found in the nests of hole-nesting and raptorial birds (Cannings 1987). The other two nestlings in this nest were near fledging when I found them dead on the ground below the nest-box with a male Northern Flicker roosting in the box. Nestlings at the

Table 2.--Northern Saw-whet Owl nesting success.

Mean Eggs Laid	Mean Clutch Size	Mean Eggs Hatched	Mean Brood Size	Mean Young Fledged	Mean No. Fledged	Overall Success
40	5.7	30 75%	4.3	17 56%	2.4	42.5%

Okanagan Falls site disappeared one by one for no apparent reason. Whole prey remains were plentiful in the nest and no ectoparasites were found in the nest or on the young; the only cause for failure I can think of is the female failing to brood and/or feed the young properly. The two youngest nestlings in another nest were apparently killed and partially eaten by their siblings just before fledging.

Nestling Growth

Young Northern Saw-whet Owls are born with eyes closed and with a covering of white down. By day 5 dark tracts of developing pin-feathers are visible dorsally, becoming very evident by day 7. The eyes open between day 7 and 10, and the nestlings begin bill-snapping at intruders at about the same time. The egg-tooth is lost around day 10, and by day 13 or 14 the primary sheaths begin to split.

The weight gain of nestlings is illustrated in figure 2. Weight gain is essentially linear (7 gm/day) from about day 4 to 14, then tapers off and reaches an asymptote at about 3 weeks of age. The large variation in weights from day 11 to 22 is due to two slow-growing nestlings which eventually died before fledging. After reaching about 100 gm, the weights of nestlings can fluctuate widely from day to day, but the mean weight of all nestlings is fairly constant until fledging. Nestlings usually lose weight after four weeks of age; the mean maximum weight of 12 nestlings was 111.0 gm while their mean fledging weight was 95.9 gm (table 3). Growth of the wing chord is essentially linear (3.9 mm/day after primary feather development starts at about day 7, and only slows slightly before fledging (fig. 3). A juvenile measured at 58 days of age had a wing chord of 131 mm, well within the adult range.

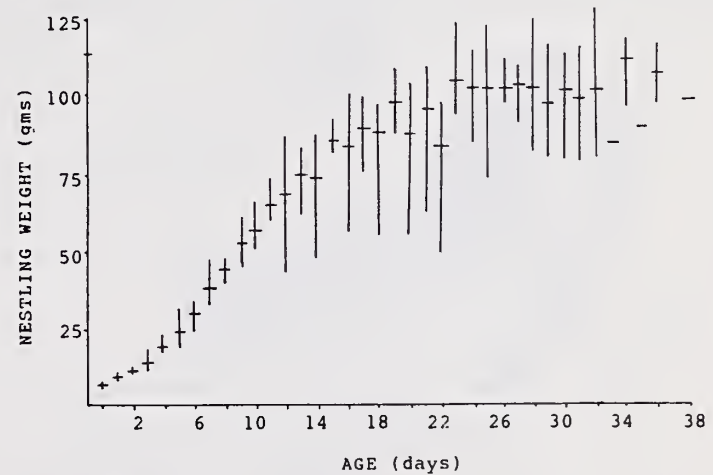

Figure 2.--Nestling weight vs. age; vertical bars are ranges, horizontal bars are means.

Table 3.--Maximum and fledging weights of nestlings from Osoyoos (deciduous woodland) and Penticton (pine-fir forest) nests.

	n	Maximum Weight		Fledging Weight (gms)	
		Range	Mean	Range	Mean
Osoyoos	6	95-123	106.5	77.5-103	86.6
Penticton	6	111-127	115.5	96-115	105.2

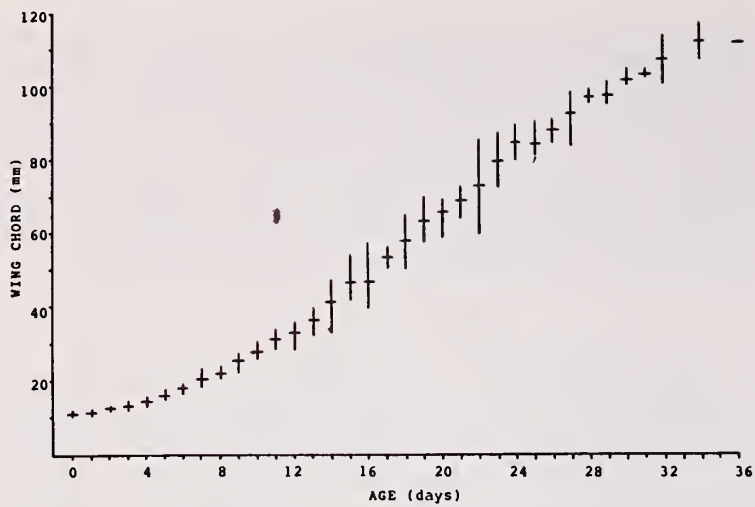

Figure 3.--Wing growth of nestling Northern Saw-whet Owls.

Home Ranges

The calculated home range sizes of the two nesting males at Osoyoos and Penticton were 142 and 159 ha respectively (figs. 4 and 5). These values are based on 21.5 hrs of radio tracking at Osoyoos and 17.5 hrs at Penticton. For 18.5 hrs of the 21.5 hrs he was monitored, the Osoyoos male stayed within a core area (approximately 27 ha) of his range, but the Penticton male regularly covered most of his home range.

Prey Densities

The results of the small mammal trapping are summarized in figure 6. Traps set in pine-fir forests caught only northwestern chipmunks (*Tamias amoenus*), deer mice (*Peromyscus maniculatus*), and one long-tailed vole (*Microtus longicaudus*); I considered the chipmunks to be too large and

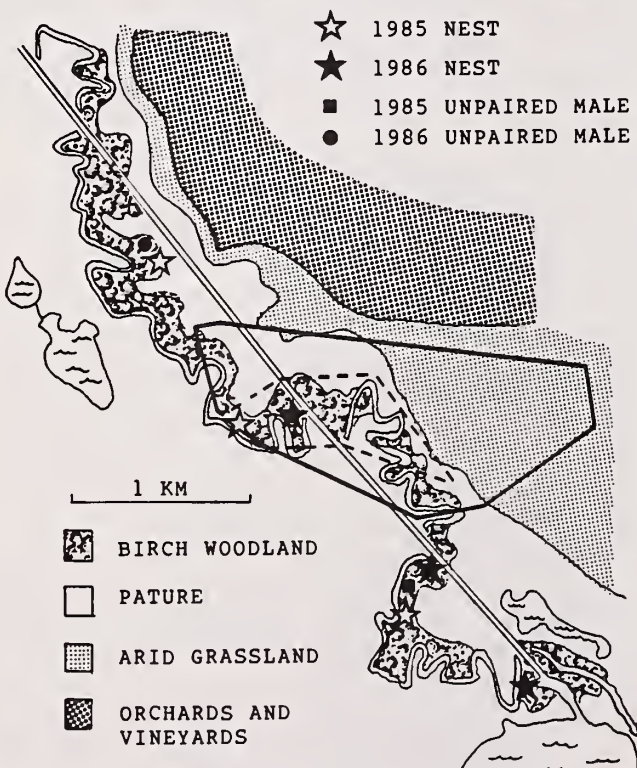

Figure 4.--The Osoyoos study area. Heavy solid line outlines the home range of male radio-tracked in 1986; dashed line outlines core area of male's home range.

diurnal to be saw-whet prey and eliminated them from the analysis. The samples from the Osoyoos area were much more diverse and indicated a prey density of at least four to five times that found in the pine-fir forests.

Diet

The analysis of prey remains found in nests and at roosts is summarized in table 4 and compared with

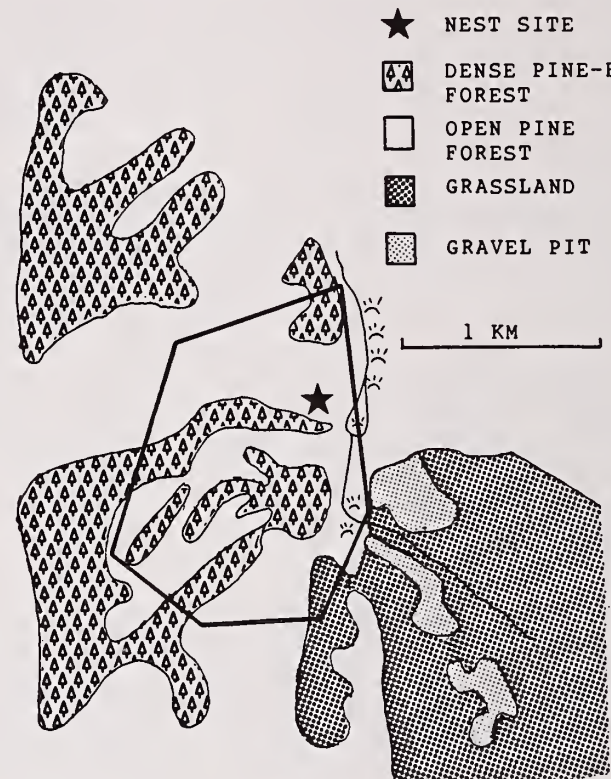

Figure 5.--The Penticton study area. Heavy solid line surrounds home range of male.

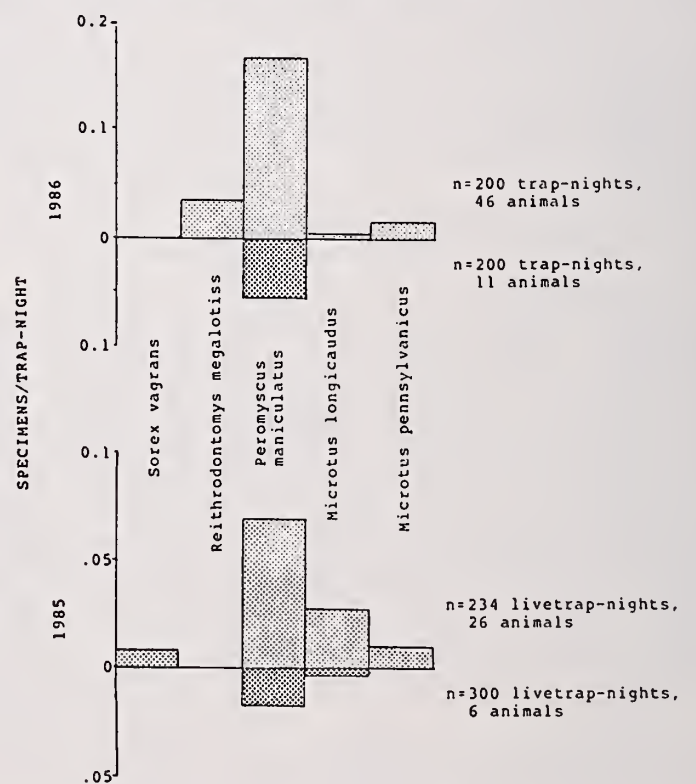

Figure 6.--Prey availability from trapping results. Light stippling: deciduous woodlands at Osoyoos; heavy stippling: pine-fir forests at Penticton and Naramata.

Table 4.--Diet of Northern Saw-whet Owls in the Okanagan Valley.

SPECIES	Weight (gm)	DECIDUOUS WOODLANDS				PINE-FIR FORESTS			
		No.	%	Total Weight	% Weight	No.	%	Total Weight	% Weight
Insects	---					6	2.3	---	---
Birds	19.4 ¹	4	1.2	77.6	1.0	5	1.9	97.0	1.9
<u>Sorex cinereus</u>	4.1 ²					1	.4	4.1	.1
<u>S. vagrans</u>	7.2 ²	8	2.4	57.6	.8				
<u>Sorex</u> spp.	5.0 ³					2	.8	10.0	.2
<u>Perognathus parvus</u>	18.3 ⁴	85	26.0	1555.5	20.4	3	1.2	54.9	1.1
<u>Reithrodontomys megalotis</u>	10.9 ⁴	13	4.0	141.7	1.9	6	2.3	65.4	1.3
<u>Peromyscus maniculatus</u>	19.5 ⁴	119	36.4	2320.5	30.5	217	84.4	4231.5	83.7
<u>Microtus</u> spp. ⁵	35.3 ⁴	98	30.0	3459.4	45.4	16	6.2	564.8	11.2
<u>Clethrionomys gapperi</u>	27.5 ²					1	.4	27.5	.5
TOTALS		327		7612.3		257		5055.2	

¹Mean weight from Dunning (1984) of four bird species found in saw-whet nests.

²Weight from Banfield (1974).

³Weight estimated from Banfield (1974).

⁴Mean weight of this species from specimens collected in the study area.

⁵Includes Microtus longicaudus, M. montanus, and M. pennsylvanicus.

estimates of prey density in figure 7. It is clear that Peromyscus maniculatus is the favoured prey in the pine-fir forests, not surprising considering the results of the small mammal trapping there. Deer mice, voles (Microtus spp.), and Great Basin pocket mice (Perognathus parvus) were about equal in numbers in the Osoyoos sample, although voles were most important when the mean weight of prey was considered. Voles predominated in early samples (March and early April), while pocket mice were rare in March but common in April samples (fig. 8). Wandering shrews (Sorex vagrans) and migrant passerines (Yellow-rumped Warbler, Dendroica coronata; White-crowned Sparrow, Zonotrichia leucophrys; Lincoln's Sparrow, Melospiza lincolni) formed a minor part of the diet at Osoyoos. In pine-fir forest habitat minor diet constituents included common shrews (Sorex cinereus), Great Basin pocket mice, long-tailed voles, meadow voles (Microtus pennsylvanicus), montane voles (M. montanus), birds (Dark-eyed Junco, Junco hyemalis; Pine Siskin, Carduelis pinus), and a few insects. The latter were found in pellets under a roost of an unpaired male.

DISCUSSION

Although the effects are not always apparent in my small sample of nests, it is clear that the pine-fir forest and deciduous woodland are markedly different habitats for Northern Saw-whet Owls. Beyond the obvious structural differences of the vegetation itself, which affect the availability and quality of roost and nest sites, the main difference is in the availability of prey. Small mammal population densities are

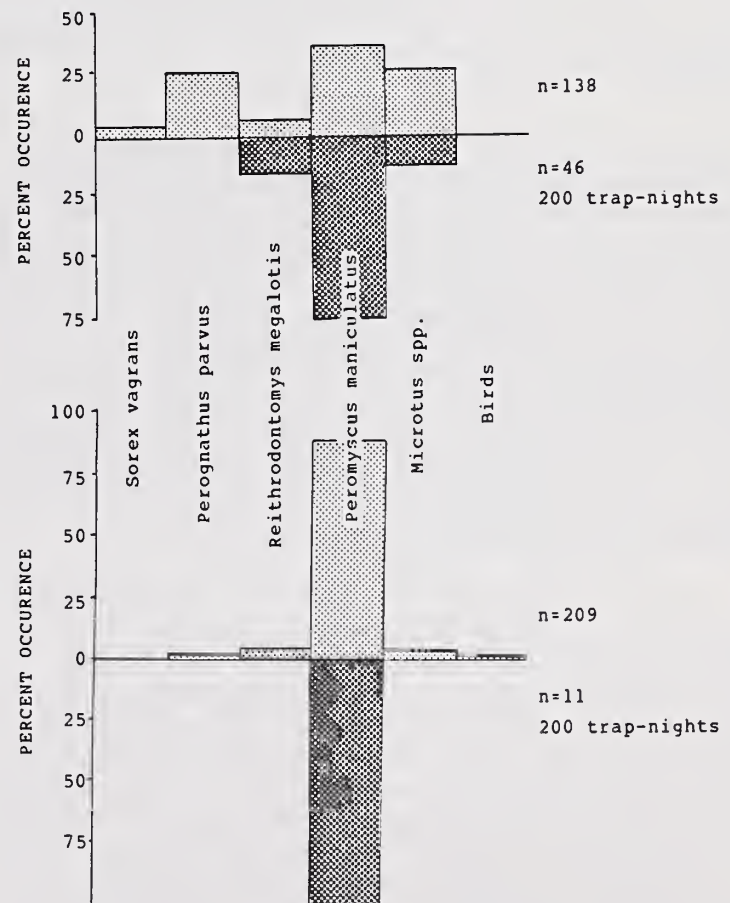

Figure 7. Comparison of 1986 prey density estimates (heavy stippling) and prey remains at nests (light stippling). Top: Osoyoos deciduous woodlands; bottom: Pentiction pine-fir forests.

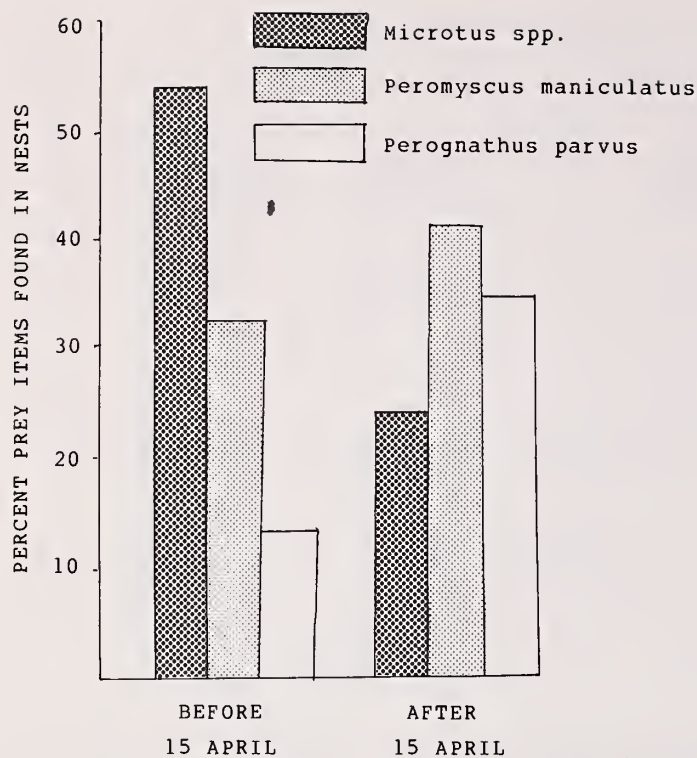

Figure 8.--Relative abundance of voles, deer mice, and pocket mice in nests at Osoyoos in early and late spring.

obviously larger in the deciduous woodlands, and prey species diversity is greater there as well. High prey species diversity would be an advantage if one prey species declines in numbers while others remain high. The dependence of saw-whets on Peromyscus maniculatus was also noted by Palmer (1986).

A confounding factor in the prey density equation is the presence of other mouse-eating raptors in the study areas. The Osoyoos area, for instance, supported at least nine pairs of Long-eared Owls (Asio otus) and one pair of Great Horned Owls (Bubo virginianus) in the woodlands and two pairs of Burrowing Owls (Athene cunicularia) on the adjacent grasslands, plus several Red-tailed Hawks (Buteo jamaicensis) and Northern Harriers (Circus cyaneus). All of these species could conceivably compete with saw-whets for small mammal prey, although none of them take Peromyscus maniculatus to any extent.

Considering the prey data and the estimated relative population densities calculated for the two habitats, I was somewhat surprised by the small difference in the calculated home range sizes (142 vs. 159 ha) for the Osoyoos and Penticton males, but the smaller core area used by the Osoyoos male helps explain this apparent similarity. More radio telemetry work is needed to determine if these home range sizes are accurate and representative. These areas are larger than the 114 ha reported for a saw-whet tracked for 20 days in November in Minnesota (Forbes and Warner 1974), but only about half of the mean of 296 ha found for Boreal Owl home ranges in Colorado (Palmer 1986).

My sample sizes are too small to detect meaningful differences in nesting success and

nestling growth between saw-whets in the two habitats. Further work will hopefully result in more accurate measures of these parameters as well as better prey availability estimates. The shifts in prey taken through the breeding season at Osoyoos are interesting. The high number of voles taken early in the season may indicate that voles form the bulk of the winter diets of Northern Saw-whet Owls, as Catling (1972) found in Ontario. Vole populations are generally high throughout the winter, then drop sharply in early spring (Krebs and Boonstra 1978). The shift to Perognathus parvus is easier to explain, since this species hibernates all winter, and "few are seen between November and March" (Banfield 1974, p. 154).

ACKNOWLEDGEMENTS

Allan Preston assisted me in all parts of the field study, from designing and helping to build the nest-boxes to radio-tracking owls in after-midnight rainshowers. Many other people helped as well, including Doug Brown, Sydney Cannings, Steve Cannings, Deb Cavanagh, John Ford, Margaret Harris, Margaret Holm, Lynn and Rich Moore, and Jeff and Sue Turner. I would especially like to thank Bill Munro, Al Peatt, Bob Lincoln, and Orville Dyer of the Ministry of Environment and Parks, Wildlife Branch for their help and cooperation, including lending me the radio receiving equipment and facilitating permits for the study. The B. C. Ministry of Environment and Parks and the Canadian Wildlife Service helped fund the construction of the nest-boxes, and other major funding came from a NSERC grant to Dr. J. N. M. Smith. I thank you all.

LITERATURE CITED

- Banfield, A.W.F. 1974. Mammals of Canada. 438 pp. National Museums of Canada, University of Toronto Press, Toronto.
- Cannings, Richard J. 1987. Infestations of Carnus hemapterus Nitzsch (Diptera: Carnidae) in Northern Saw-whet Owl nests. Murrelet 67:83-84.
- Catling, Paul M. 1972. Food and pellet analysis studies of the Saw-whet Owl (Aegolius acadicus). Ontario Field Biologist 26:1-15.
- Dunning, John B., Jr. 1984. Body weights of 686 species of North American birds. Western Bird Banding Association Monograph No. 1. 38 pp.
- Forbes, James E., and Dwain W. Warner. 1974. Behaviour of a radio-tagged Saw-whet Owl. Auk 91:783-795.
- Godfrey, W. Earl. 1986. Birds of Canada. National Museums of Canada, Ottawa.
- Krebs, Charles J., and Rudy Boonstra. 1978. Demography of the spring decline in populations of the vole Microtus townsendii. Journal of Animal Ecology 47:1007-1015.
- Murray, Gale A. 1976. Geographic variation in the clutch sizes of seven owl species. Auk 93:602-613.
- Palmer, David A. 1986. Habitat Selection, movements, and activity of Boreal and Saw-whet Owls. MSc. thesis, Colorado State University, Fort Collins, Colorado.

Study of a Northern Saw-Whet Owl Population in Sauk County, Wisconsin¹

Scott R. Swengel and Ann B. Swengel²

We censused a population of Northern Saw-whet Owls (*Aegolius acadicus*) in 1986 in southern Wisconsin, using the spot-mapping method. Saw-whet Owls called voluntarily from 21 February to 27 April, and last responded to taped calls on 14 May. Their detectability was high in March and dropped considerably in April. Auditory censusing in March and April using tape-recorded calls yielded 18 Saw-whet Owls along a 7.2-km survey route. Population density was 5.0 singing Saw-whet Owls/km²; one 116-hectare area had a density of 12.9 singing Saw-whet Owls/km². We surveyed most of this route for Eastern Screech-Owls (*Otus asio*) with tape playback. The distribution of Saw-whet Owls and Screech-Owls was remarkably disjunct, with only slight overlap of these species; this segregation was statistically significant ($P < .001$). Saw-whet Owls occurred in large tracts of forest, including pine plantations, whereas Screech-Owls occupied forests near open areas. We noted 11 instances of interspecific call answering to tape playback by these two species. Pellets of Saw-whet Owls were measured and their contents analyzed. Roost sites of Saw-whet Owls were adapted to the different sizes, growth habits, and canopy of each tree species.

DESCRIPTION OF STUDY AREA

We studied a population of Northern Saw-whet Owls (*Aegolius acadicus*) from February to December 1986 in the Baraboo Hills of Sauk County, Wisconsin. The Baraboo Hills are a range of bluffs and hills up to 150 m above the surrounding terrain in Sauk and Columbia Counties, Wisconsin. Although the Baraboo Hills are south of the tension zone between northern mixed hardwood-coniferous forests and southern deciduous forests and prairies, several northern forest types are found here and Mossman and Lange (1982) state that "...a typical forest in the Baraboo Hills might best be described as intermediate between northern and southern types" (p. 19). White pine islands grow on the exposed talus slopes and cliffs, jack pine-oak barrens on the infertile sandy areas, southern oak hardwoods in the flatter, lower areas, upland forests dominated by oak (a southern forest type) or maple (a northern forest type) in the drier areas, with northern communities in the stream gorges and rocky bluffsides. Pine plantations are scattered throughout the area.

¹Paper presented at the symposium, Biology and Conservation of Northern Forest Owls, Feb. 3-7, 1987, Winnipeg, Manitoba, Canada. USDA Forest Service General Technical Report RM-142.

²Scott R. and Ann B. Swengel, 315 Fourth Avenue, Baraboo, Wisconsin 53913 USA

Our four study areas are Baxter's Hollow, a stream gorge in the western Baraboo Hills; Devil's Lake State Park south shore area, a rugged area containing all the communities discussed above except pine barren; Steinke Basin in Devil's Lake State Park, a basin with wet meadow and prairie with deciduous oak forest and pine plantations on the perimeter; and Mirror Lake Pine Barren, immediately north of the Baraboo Hills, a jack pine-oak-red cedar barren with dry prairie. Immediately around the pine barren are pine plantations and oak hardwood forests. The study sites are located at 43° 23' to 43° 34' N and 89° 41' to 89° 49' W, and vary from 270 to 450 m in elevation.

The Eastern Screech-Owl (*Otus asio*) is a resident breeder in agricultural, urban, and woods-edge habitat in the Baraboo Hills, while the Saw-whet Owl is considered a possible breeding bird (Mossman and Lange 1982). Follen (1981, 1982) has reviewed the status of Saw-whet Owls in Wisconsin and found only one nest record at or south of the latitude of our study area during the 20th century: 11-27 July 1953, Milwaukee County, 4-5 eggs in the nest, reported by Schwendener in the *Passenger Pigeon* 15: 178 (1953) (as cited by Follen 1981).

METHODS OF DETECTING OWLS

Our first method of detecting owls was listen-

ing for voluntary calling. At dusk we selected a listening station and sat there motionless for the duration of the observation period. It was important to arrive before the owls began calling, not only to record that fact but also because it appeared to disturb them if we moved in their vicinity after calling began but before it was fully dark. We recorded the beginning and ending time each time an owl called as well as the direction from us to the owl's calling station. Absolute silence greatly increased the number of vocalizations we heard.

Our second method, auditory censusing with tape-recorded calls, used the strip transect method of censusing (Ralph 1981). We spot-mapped the calling records as Emlen (1984) did in censusing songbirds. For Saw-whet Owls, we used a calling tape which consists of ten 40-second sequences of the Saw-whet Owl song as recorded on "Voices of New World Nightbirds" (ARA Records, Inc.; available from the Laboratory of Ornithology, Cornell University, Ithaca, New York, USA) separated by a blank section of tape, and listening stations spaced 100 m apart. In one later census we used 200 m intervals between listening stops to increase our efficiency. Using a portable cassette recorder and starting after nightfall, we played 20 seconds of song, paused to listen, played the remaining 20 seconds of song, and paused again to listen.

For Eastern Screech-Owls, we used a calling tape of 12 monotone (trill) songs of the species as recorded on "A Field Guide to Bird Songs of Eastern and Central North America" (Cornell Laboratory of Ornithology, Ithaca, New York, USA), and listening stations spaced 200 m apart. Using a portable cassette recorder and starting after dark, we played 3-4 songs, paused to listen, played 3-4 more songs, and paused again to listen. During every census, we recorded any response by any species of owl, describing the vocalization, the direction of the calling station relative to us, the duration of the vocalization, and any other relevant observations.

Our third method of detection was visual location during the day. From February to December, we systematically searched locations in the four study areas for fecal wash and pellets of Saw-whet Owls. During these searches we looked for roosting Saw-whet Owls. When we located a Saw-whet Owl, we quickly recorded its roost data and behavior and then left the vicinity. When sufficient fecal wash was present to identify the location of the roost, its height, its distance from the trunk, the length of the roost branch, and the tree species were noted. The height and diameter at breast height (dbh) of roosting trees were also recorded. Pellets were collected regularly from roosting areas and were analyzed individually; they were soaked in 0.03 molar NaOH for 1-4 days or simply picked apart.

RESULTS OF DETECTING SAW-WHET OWLS

We initiated listening sessions for voluntary calling of Saw-whet Owls on 21 February and discontinued on 7 March 1986, with attempts on nine nights, all in the same area in Devil's Lake State

Park, south shore near stop 19 (fig. 1). We began listening before sunset and the observation period lasted 22 to 62 minutes. On the six nights in which winds were less than 15 km per hour, we heard at least one owl (Swengel and Swengel 1986). With this method, we found 5 owls, numbered 8-12. In addition to our observations, we received 4 records of voluntary calling from another competent observer. Saw-whet Owls called voluntarily from 21 February to 27 April. However, they had probably begun calling earlier, since we heard voluntary calling on the first night in which we listened for it. K. Lange (pers. comm.) has heard voluntary calling in our study area as early as 10 February.

We censused Saw-whet Owls with tape-recorded calls in three of the four study areas. At Devil's Lake, south shore area, where most surveying occurred, the strip transect consisted of 75 stops spaced 100 m apart along two transects that intersected. One transect (stops 1-56) was 5.5 km long and the other (stops 57-75) was 1.7 km long (fig. 1). Stops 13-56 were surveyed for Screech-Owls and stops 1-75 were surveyed for Saw-whet Owls. Because the Saw-whet calling period was so short, we concentrated our censusing in the densely populated western end of the Devil's Lake survey area, where repeated censusing was necessary to determine how many Saw-whet Owls were present. Consequently, other listening stations were censused only once or twice. Baxter's Hollow was also surveyed for both species and Steinke Basin for Saw-whet Owls only. Saw-whet Owls responded to tape playback on the first census on 9 March and continued to respond until 14 May. Auditory censusing in March and April using tape-recorded calls of Northern Saw-whet Owls yielded 17 Saw-whet Owls, numbered 1-13 and 15-18, along the 7.2-km survey route. Auditory censusing from March to May in the Steinke Basin and Baxter's Hollow yielded six more owls, numbers 19 and 21-25. Two additional owls, number 14 at Devil's Lake south shore and number 20 at Baxter's Hollow, were only observed by us to respond to the Eastern Screech-Owl tape, although another competent observer documented response by number 20 to a Saw-whet Owl tape.

The ease with which we found wash, pellets, and/or owls--i.e. the success of visual location during the day--varied considerably. Saw-whet Owl 22 was seen on seven days from 17 March to 4 November, and heard once during the day on 23 March. Owl 24 was sighted once on 30 March. Eastern Screech-Owl E or F was heard during the day on 29 March. On 21 additional days, fecal wash and/or pellets of Saw-whet Owls were located. Attempts were made on at least nine additional days. Pellet and roost analyses are discussed later.

DISCUSSION OF DETECTION METHODS

Each of the three methods of detection has advantages and disadvantages. Visual detection is the slowest and most time-intensive, and probably never will yield an accurate census of Saw-whet or Eastern Screech-Owls. Certainly, the history of observations of Saw-whet Owls and, to a lesser extent, Eastern Screech-Owls in the Baraboo Hills did not

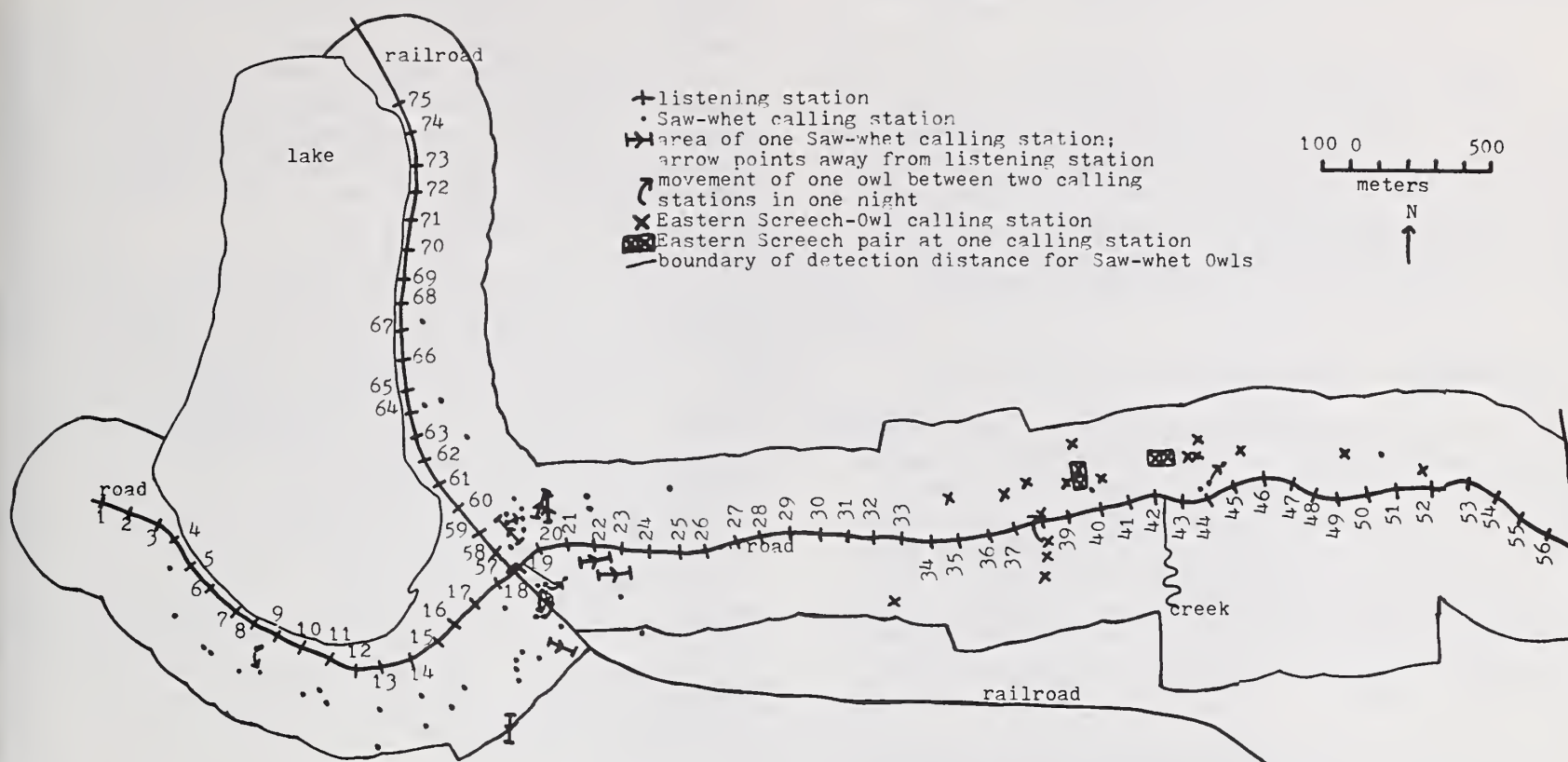

Figure 1. Map of Devil's Lake State Park, south shore area and Steinke Basin, showing the census route, numbered listening stations, area in which Saw-whet Owls were detectable, and the calling records of different Saw-whet Owls and Eastern Screech-Owls.

prepare us for the results we obtained with the other two methods. However, visual searching is the only way to study pellets and roost site selection. Furthermore, in the absence of vocalizations--and the Saw-whet Owl in particular is very seasonal in vocal response--visual detection is the only realistic method of detection. However, at the same time that it becomes difficult to elicit vocal responses, it also becomes more difficult to find pellets and roosts. We believe the warmer weather and presence of hungry invertebrates erases the evidence quickly. Many pellets we collected during the late spring and summer contained small beetles that had burrowed into the pellets. Wilson (1938) found that small pellets decompose within four to six weeks during the spring, but last 3-5 months during winter. Of course, it is always difficult to find the owls themselves. Diurnal observations are also the only way to gather data on nesting behavior and success and the only way to observe the owl, although this is only during the owl's less active time.

Listening for voluntary vocalizations is a seasonal method, but at the right time of year it is more efficient in detecting Saw-whet Owls than daytime searches. It is also the only way of those methods we used to observe nocturnal behavior of the owls unaffected by human intrusion. During our listening sessions, we noted instances in which Saw-whet Owls appeared to approach and respond to each other, apparently oblivious to their human audience.

Auditory censusing at the right time of year is by far the most efficient means of censusing Saw-

whet and Eastern Screech-Owls. One must, however, determine the peak calling period of the Saw-whet Owls in the area if one wishes to census an area in the fewest evenings. For example, on 9 March, we elicited responses from all the owls we ever detected in the area we censused that night; however, we can only know that from repeated surveys of the area. We only experienced 100% detectability twice, on 9 March at Devil's Lake south shore and on 27 March at the Steinke Basin, so it probably is not a common occurrence. Tape playback and, more time intensively, listening for voluntary vocalizations enable censusing of areas that are all but inaccessible on foot. Calling data also greatly improves the efficiency of visual searching during the day.

One method we did not use is banding/recapture. This requires location of the owl on a day roost, capture of the owl, attaching a band and/or other visual markers on the owl, release, and attempts to re-identify the same individual by recapture. This is one way of monitoring the location of individual owls. We have considered this method, but feel it is not appropriate for our purposes. Mumford and Zusi (1958) found that the bands and marks they placed on Saw-whet Owls were rarely observable without recapturing the owl and they were often unable to catch a given owl to confirm its identify. Frequent recapture of the owls is likely to affect their behavior, thus biasing the results. From our observations of the diurnal behavior of the Saw-whet Owl, we believe that Saw-whet Owls become increasingly skittish the more human intrusion they experience and become more inclined to flush off their

roosts and roost in progressively more inaccessible locations the more often the intrusions occur.

Radiotelemetry is the best method of collecting data on the movements or site fidelity of an owl. It has been used to study home range size and habitat use (Forbes and Warner 1974) and roost site selection (Hayward and Garton 1984) in Saw-whet Owls. This requires capturing the owl only once, and allows the observer to monitor the owl from a distance. We have also not attempted this method.

METHODS OF ANALYZING DATA ON SAW-WHET OWLS

We analyzed the results from the three methods of detection together in order to reveal the most about the individual Saw-whet Owls. First, we marked the location and date of all records of Saw-whet Owls on an enlarged 1:24,000 topographic map. Visual records were indicated by a dot and calling records by drawing a line from our listening station in the direction of the calling station of the owl. We used the term calling station (Savage 1965) for each calling site.

However, we needed to determine the locations of the calling records more precisely than simply a point somewhere along a straight line of unknown length. We identified the instances where the calling station could be triangulated because we heard the same owl in the same evening while we were at different listening stations. We measured on the map the length of each triangulating (intersecting) line from the listening station to the point where the lines intersected. The point where the lines intersect is the approximate location of the owl.

We grouped the triangulation data according to the habitat between the calling owl and our listening station (e.g. open area or forest), since the detection distance of Saw-whet Owl calls varies according to the habitat through which it is heard (table 1). The different vocalizations of the Saw-whet Owl probably also vary in detection distance, but we believe the series (typical) call has the

Table 1. Detection distance of Saw-whet Owl songs in different habitats.

Habitat	N owls	-----Distances-----			
		N	mean (m)	range (m)	median (m)
Forest	6	18	172.5	92-280.5	150-157
Mixed Forest- Open Area	5	10	297	225-393	281-292
Open Field	1	3	546	472-674	494
Across Lake	2	5	1084	983-1236	1056
Brushy Area	1	4	76	45-112.5	61.5-84.5

Note: When more than two lines triangulated a particular calling station, the line did not always intersect precisely. In that case, we used the range of distances each line could be when calculating the median and the average of these distances in calculating the mean.

greatest audible distance of the calls we have heard, if only because there is generally a greater amount of time in which to hear it. Therefore, we used only the series call in the triangulation analysis. We calculated the detection distance to triangulated owls in each habitat type--forest, mixed open and forest, open areas (lake and field), and open brush, although the sample size was small for the last two categories.

We reasoned that the mean distance of triangulated calling stations from the listening station provided a statistically valid basis for estimating the location of untriangulated calling records. Thus, we marked the mean distance from listening station to calling station of triangulated records in the appropriate habitat on the lines we drew on our maps for each untriangulated calling record to indicate the probable location of the owl's calling station. If there was reason to believe that the record was appreciably closer or farther than the mean distance in that habitat, we indicated both the minimum and mean, or the mean and maximum distances, as appropriate. Thus, our maps now had dots to indicate visual records and either a dot or a line segment to indicate calling records (fig. 2).

Next we determined the minimum number and location of composite calling stations (composites), a term we coined to denote all the calling stations in an area used by a single owl. The scattered distribution and considerable density of calling records precluded any obvious conclusions about how many owls we had detected. We used simultaneous or nearly simultaneous calling by nearby owls on a given night as the basis for designating different owls for two calling stations. We drew boundary lines separating these calling stations from each other (fig. 2). All stations grouped together, rather than separated from each other, by these lines belong to the same composite calling station. We drew a circle around each composite as a visual aid in our research (fig. 3 and 4). These circles are not intended to represent territories.

We used the estimated detection distance in each habitat to create a strip map of the area covered by our auditory censuses (fig. 1). The width of the strip map at each listening station depends on the openness of the habitat at that station. We drew arcs from each listening station at the estimated detection distance for the habitat to generate the margins of the strip census area.

Since a Saw-whet Owl at the maximum detection distance from the nearest listening station is not likely to be audible from another listening station, it would be rare to triangulate an owl that was barely audible. For this reason we believe that our greatest triangulation distances for the owls were slightly shorter than the actual detection distance. We estimate that the detection distance of Saw-whet Owls in our area was about 300 m through forests, 400 m through mixed forest and open areas, and 700 m over open fields. These figures are all slightly higher than the greatest triangulation distances in their respective habitats that are listed in table 1 but are rounded up within the error allowance for

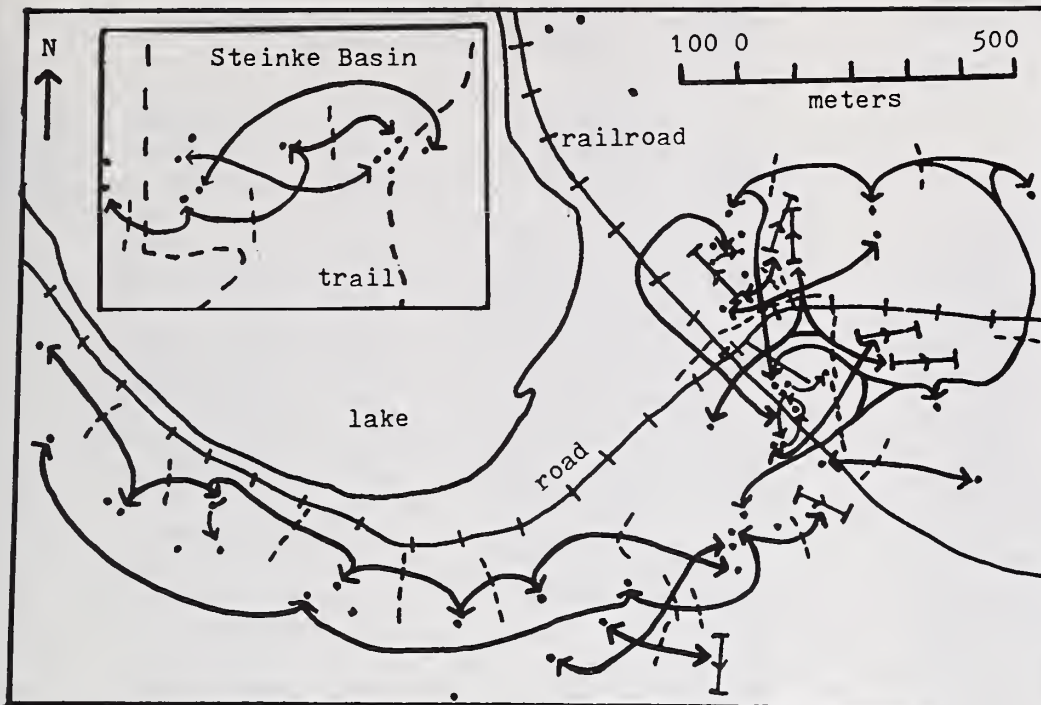

listening station (LS)
 Saw-whet calling station (CS)
 area of one Saw-whet CS; arrow
 points away from LS
 movement of one owl between two CS
 in one night
 Eastern Screech-Owl CS
 Eastern Screech pair at one CS
 calling records of individual owls
 on the same night--each arrowpoint
 indicates a different owl
 emphasizes distinction between CS
 of different owls

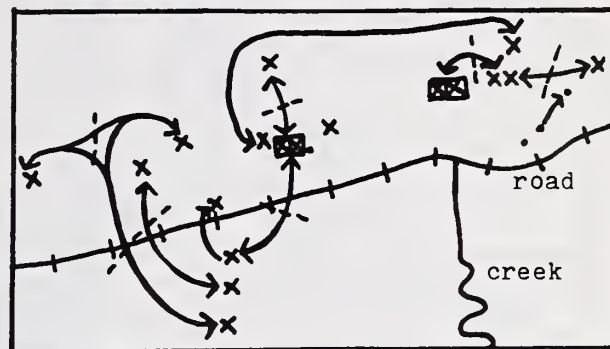

Figure 2. Map of Devil's Lake State Park, south shore area and Steinke Basin, indicating the calling records of different Saw-whet Owls and Eastern Screech-Owls on the same night with arrowpoints connected by the same line.

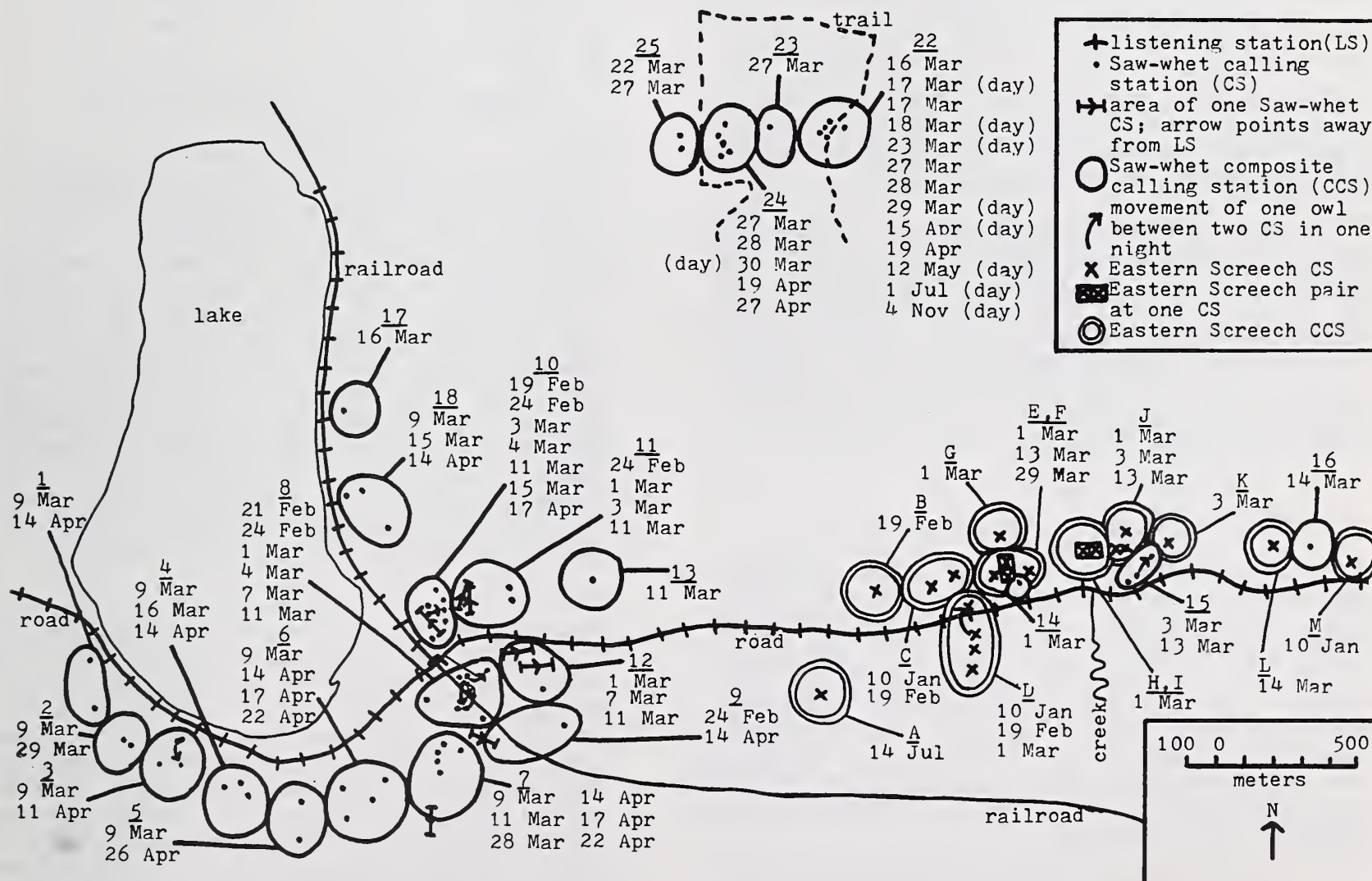

Figure 3. Map of Devil's Lake State Park, south shore area and Steinke Basin, indicating the calling stations and the composite calling stations of Saw-whet Owls and Eastern Screech-Owls.

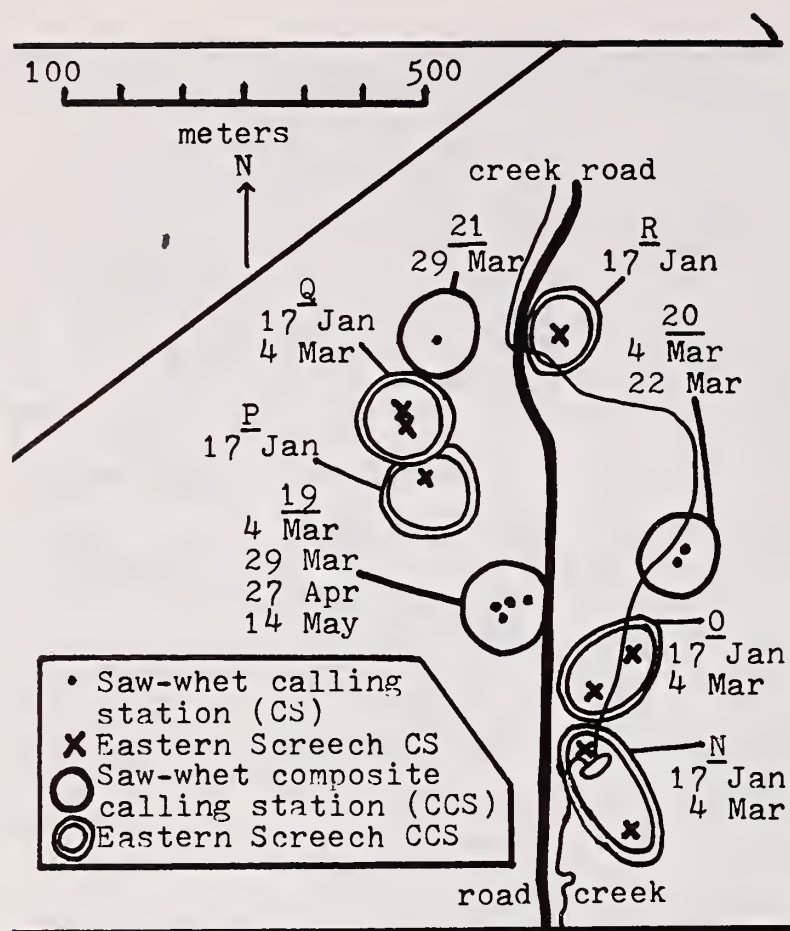

Figure 4. Map of Baxter's Hollow, indicating the calling stations and composite calling stations of Saw-whet Owls and Eastern Screech-Owls.

the scale of our map. We did not extrapolate a detection distance from the triangulations in open brushy areas; the only such area was very small and was immediately adjacent to our transect.

Since we determined the number of composite calling stations and created the strip map, we were able to calculate the density of Saw-whet Owls per unit of censused area. We also calculated the area of forest and area of open habitat in our strip census area based on the vegetation analysis in Druckenmiller (1978) and then calculated the density of Saw-whet Owls per unit area of forest, since we found Saw-whet Owls only in forested areas.

RESULTS OF ANALYZING DATA ON SAW-WHET OWLS

We identified 25 composite calling stations for Saw-whet Owls, numbered 1-25, with 18 in the Devil's Lake south shore area, 3 at Baxter's Hollow, and 4 in the Steinke Basin (fig. 3 and 4). Table 2 lists the calling time range for each composite calling station. If we eliminate from consideration those composites which received only one day of listening observation (composites 13, 16, and 17), the average calling period per composite was 28.1 days (range 1-71, median 31 and 33 days), with 3.1 calling records (range 1-7) per composite.

We believe that each composite calling station is used by only one owl for several reasons. First, although we noted five instances in which an owl moved, three occurred during our listening sessions for voluntary vocalizations. At such times we were

Table 2. Calling records per composite calling stations (CCS) of Saw-whet Owls.

CCS	Range of calling records	Calling range N (days)	Range of listening dates	N listening dates	
1	9 Mar-14 Apr	2 36	9 Mar-14 Apr	2	
2	9 Mar-29 Mar	2 20	9 Mar-14 Apr	3	
3	9 Mar-11 Apr	2 33	9 Mar-14 Apr	3	
4	9 Mar-14 Apr	3 36	9 Mar-14 Apr	3	
5	9 Mar-26 Apr	2 48	9 Mar-26 Apr	5	
6	9 Mar-22 Apr	4 44	9 Mar-26 Apr	7	
7	9 Mar-22 Apr	6 44	9 Mar-26 Apr	8	
8	21 Feb-11 Mar	6 18	21 Feb-26 Apr	14	
9	24 Feb-14 Apr	2 49	24 Feb-26 Apr	13	
10	19 Feb-17 Apr	7 57	19 Feb-26 Apr	15	
11	24 Feb-11 Mar	4 15	21 Feb-14 Apr	10	
12	1 Mar-11 Mar	3 10	24 Feb-14 Apr	8	
13	11 Mar	1 1	11 Mar	1	
14	1 Mar	1 1	1 Mar-13 Mar	2	
15	3 Mar-13 Mar	2 10	3 Mar-28 Mar	3	
16	14 Mar	1 1	14 Mar	1	
17	16 Mar	1 1	16 Mar	1	
18	9 Mar-14 Apr	3 36	9 Mar-14 Apr	4	
19	4 Mar-14 May	4 71	4 Mar-14 May	4	
20	4 Mar-22 Mar	2 18	4 Mar-14 May	4	
21	29 Mar	1 1	4 Mar-14 May	3	
22	16 Mar-19 Apr	5 34	16 Mar-27 Apr	6	
23	27 Mar	1 1	27 Mar-27 Apr	4	
24	27 Mar-27 Apr	4 31	27 Mar-27 Apr	4	
25	22 Mar-27 Mar	2 5	27 Mar-27 Apr	5	
		19 Feb-14 May 71	1-71	19 Feb-14 May	

Notes: Other competent observers provided one record each of owls 3, 4, 19, 20, and 25; these records are included in N calling records and in N listening dates. Owls within range that they did not hear are not counted. Auditory censusing for Eastern Screech-Owls within range of a Saw-whet Owl is counted as a listening date only if the Saw-whet responded. Owl 9 was always barely within our audibility range. Audibility of owl 23 declined drastically in April because of frogs. Listening dates after the date of last calling by a Saw-whet Owl (14 May) are excluded. Listening dates on which audibility was poor are also excluded. Several owls responded to tapes being played across the lake, a distance of a kilometer. We counted such cases as a listening date only when the owl responded.

sedentary and listened to each owl for a longer period of time. In these cases, if the calling owls were responding to a vocalization, they were responding to a neighboring owl instead of a recording. However, during auditory censusing, we noted many more triangulations than movements, indicating a strong tendency to remain on one perch, even when several neighbors responded at the same time to the tape. Second, many Saw-whet composites had a time range exceeding a month, indicating considerable consistency and site fidelity by the owls. The simplest explanation for this pattern is that the same owl is responsible for all the calling records in the area of each composite calling station.

Thus, we believe that the composite calling stations we have identified are each used by one owl. Furthermore, from the evidence of several of the composites--5, 19, and 22 in particular--we believe that a good number of the composites correlate with the territories of resident Saw-whet Owls, although we do not know how large the territories are. The data for many of the composites are scanty enough to permit other interpretations, such as wintering or transient owls. Most owls called for too long a period from the same area to be transients. Catling (1971) found that owls he located and banded during the spring migration near Toronto, where the latitude (43° 41' N) is similar to that of our study area, were invariably gone from the area within two days. In the absence of vocal records, it is difficult to confirm the presence of a Saw-whet Owl in late spring and beyond. As further corroboration that the species is resident, we sighted an owl in composite 22 on 1 July and two competent observers sighted an immature Saw-whet Owl on 1 June in another area of the Baraboo Hills of Sauk County (K. Lange and P. Druckenmiller, pers. comm.). We also found a few pellets regularly throughout the summer in the area of composite 22.

The detectability of Saw-whet Owls was very high in March and dropped considerably in April. Saw-whet Owls began calling voluntarily around sundown while it was still twilight and remained responsive to the tape well after that. We did not continue to listen for voluntary calling after an hour past sundown--sometimes an owl was calling as we terminated the listening session, and we did no observations of any kind after 2200 hrs. Once we heard a Saw-whet Owl call during the day (1112 hrs on 23 March) after we had done a visual search of the area. The series (typical) call is generally audible for only several hundred meters, but we have occasionally heard this call across Devil's Lake for a distance exceeding 1 km (table 1).

During the listening sessions for voluntary calling, we were nearest owl composites 8 and 10. These composites are across the road from each other. On two evenings (24 February and 4 March), these two owls called simultaneously. On the latter date, we noted much interaction between these two owls. At 1739 hrs, owl 8 initiated calling and the two exchanged vocal responses nine times until 1837 hrs. During this time, both owls moved toward each other and then away from each other. On 7 March, owls 8 and 12, also adjacent to each other, exchanged vocal responses three times. Owl 10 did not call during the listening session that evening.

The census area along our strip transects contained 3.60 km² from which Saw-whet Owls were audible. The population density was 5.0 calling Saw-whet Owls/km² and 7.2/km² of forested area. One 116-hectare area, from stops 4 to 27 and stops 57 to 60, intersecting each other, contained 15 calling Saw-whet Owls, for a maximum density of 12.9/km² and 15.8/km² of forested area. In this high density area we found calling owls at approximately 250 m intervals along the transect. Because of the even distribution of owls in this area and our numerous censuses of it, we believe this density approaches

the maximum density of the species in this habitat and area.

DISCUSSION

Catling (1971) found that the spring migration of Saw-whet Owls near Toronto began about 24 March, peaked 12-20 April, and ended about 25 April. Our results suggest that most of the Saw-whet Owls we heard were either winter residents or breeding birds. We heard five different owls call after 20 April, which is the end of the peak migration period at our latitude (Catling 1971). Catling also states that Saw-whet Owls wintering in his area left during March. Owl 22, in whose composite we saw a Saw-whet Owl on 12 May and 1 July, did not call after 19 April. For this reason, we believe that failure to hear certain owls after mid-April does not necessarily mean they had left the area. Also, our main census route receives so much usage by people from May to September that censusing is very difficult during these months. Although 18 of the 25 Saw-whet Owls that we found were along this route, our three latest calling records were from other areas, where human-generated noise was not as much of a problem. Brewster (1925) noted a calling period for Saw-whet Owls in Maine that was similar to ours, tapering in late April and becoming irregular in May.

Studies in Wisconsin (Follen 1981, 1982) and Michigan (Curtis 1963a, b) indicate that the most likely egg laying period at our latitude is early April. Follen and Haug (1981) reported a nest with eggs on 18 March about 100 km NNW of our study area. Since the incubation period for Saw-whet Owl eggs is 26-28 days and the fledging period is about 34 days (Eckert and Karalus 1974), the fledged immature Saw-whet Owl seen on 1 June 1986 in the Baraboo Hills must have hatched from an egg laid no later than the first week of April. Since nest initiation occurs around the beginning of April, many of the Saw-whet Owls we heard (12 out of 20 composites censused after 10 April) were calling during the normal breeding period and may well be breeders. Coincidentally or not, the responsiveness of Saw-whet Owls to taped calls dropped markedly during the first half of April, when most eggs are probably laid.

Our maximum density of 12.9 calling Saw-whet Owls/km² and 15.8/km² of forest is similar to the density of one pair/40 acres (12.4 individuals/km²) reported by Johnson et al. (1979) in Arizona, but we do not know whether they assumed a pair was present for each calling owl. Simpson (1972) conducted auditory censuses in North Carolina at the southern tip of the eastern breeding range of Saw-whet Owls and found one active calling station per 2.63 km of transect, a much lower density than we found. Vanderschaegen (1981) and Follen (1981) mention instances of large numbers of Saw-whet Owls occurring in two areas of northern Wisconsin, but do not give density estimates.

CENSUS OF EASTERN SCREECH-OWLS

Along the 4.4 km of census route surveyed for

Eastern Screech-Owls (*Otus asio*) with tape playback, we found 13 Screech-Owl composite calling stations, lettered A-M (fig. 3). In Baxter's Hollow, we found five, lettered N-R (fig. 4). We mapped these records according to the methods described for Saw-whet Owls. We did not have a sufficient sample of triangulations for this species to determine detection distances. However, we used the few triangulations available to assist in mapping the records accurately. Habitat features also helped, in that open areas beyond and interspersed in the forests lining the route limited the possibilities for roost locations. We noted pairs when two voices overlapped from the same location. We considered the composite for each member of the pair to overlap completely with the other's, although this may be proven wrong with further research. The number of Screech-Owls was determined in the same way as for Saw-whet Owls, by noting records from different locations on the same night.

Eastern Screech-Owls also showed a strong pattern of consistency in their composite calling stations. This is not surprising since they are a resident species. Although Screech-Owls showed more of a tendency than Saw-whet Owls to move in response to the tape, they usually stayed in one place. It is easier to determine whether a Screech-Owl has moved because of the distinctive pitch and style of individual Screech-Owl voices.

The distribution of Saw-whet Owls and Eastern Screech-Owls was remarkably disjunct, with only slight overlap of these species; this segregation was statistically significant ($P < .001$). Saw-whet Owls occurred in large tracts of forest, including pine plantations, whereas Screech-Owls occupied forests with more open areas ($P < .001$). We found neither species of owl in the area from stops 27 to 33, between the area of Saw-whet Owl concentration and the area of Eastern Screech-Owl concentration. This area is vegetated with lowland deciduous forest, a southern forest type.

We noted 11 instances of interspecific call answering to taped call by these two species during our playback census. Five individual Saw-whet Owls responded six times to Eastern Screech-Owl tapes, and three to five individual Screech-Owls responded to Saw-whet tapes. Hayward (1983) has also noted interspecific call answering by Saw-whet Owls.

VOCALIZATIONS OF SAW-WHET OWLS

We noted a variety of vocalizations for this species. The territorial song was by far the most commonly heard vocalization. It consisted of a single short high-pitched note which was repeated at consistent intervals, often for a great length of time. Volume sometimes varied, although after careful observation it generally became apparent that the owl had not moved appreciably. The owl had probably been projecting its call in several directions, and this probably accounts for the ventrilocal effect reported by some authors. If the vocalization lasted sufficiently long for us to pinpoint its direction, we did not find this "ven-

triloquism" confounding. If the owl moved between vocalizations, great care was required in attributing the vocalization to the right individual. As discussed above, we noted several times in which movement by an individual owl was apparent. We do not believe that the owls were moving about very much because of the consistency of each composite's location. Sometimes an owl accelerated the rate of the notes in the song. Conversely, we have also noted an interval greater than the observed norm. The series vocalization is well known and is represented on various bird song recordings, such as "Voices of New World Nightbirds" and "A Field Guide to Bird Songs of Eastern and Central North America" mentioned above.

We also identified four additional vocalizations: a harsh, short shriek (probably an alarm call); an ascending, single-noted wail ("saw-whet call"), a single, long whistle similar in pitch and tone to the song note, and a lower-pitched, isolated descending call. We attributed these vocalizations to the Saw-whet Owl on the basis of one or both of the following means. First, the vocalization immediately preceded or followed the song and came from the same direction and at comparable volume. Second, the location of the vocalization triangulated with a record of a series call on the same evening. The "saw-whet" call is also on "A Field Guide to Bird Songs of Eastern and Central North America."

ROOSTS OF SAW-WHET OWLS

We found Saw-whet Owl roosts in seven species of coniferous trees in our study area: White Spruce (*Picea glauca*), Jack Pine (*Pinus banksiana*), Red Pine (*Pinus resinosa*), Eastern Red Cedar (*Juniperus virginiana*), Eastern White Pine (*Pinus strobus*), Eastern Hemlock (*Tsuga canadensis*), and Norway Spruce (*Picea abies*). Over 95% of the roosts were in five species of trees--White Spruce, Jack Pine, Red Pine, Eastern Red Cedar, and Norway Spruce. The roost height was positively correlated with the height of the tree and was low in densely foliated trees and high in sparse trees. Table 3 shows that the mean roost height and mean tree height is lowest for Eastern Red Cedars, the densest of the five trees, followed in order by Jack Pine, White Spruce, Norway Spruce, and Red Pine.

Although we found many pellets under Red Pines, we were usually unable to determine how high the owl had roosted, since there were few branches to catch

Table 3. Typical roost sites of Saw-whet Owls.

species	Tree		Roost		
	mean height (m)	N	mean height (m)	sd (m)	range (m)
Eastern Red Cedar	4.3	5	1.57	0.32	1.37-2.13
Jack Pine	5.3	33	1.91	0.64	0.76-3.66
White Spruce	6.6	41	2.76	0.79	0.69-4.88
Norway Spruce	10.1	5	4.38	2.09	1.95-7.30
Red Pine	11.6	6	5.92	1.32	3.96-7.62

white wash below the roost to give us clues where the exact roost site was. Saw-whet Owl roosts in Red Pines were usually about 6 m high, just above where the foliage begins, and averaged 63 cm (N=7) from the trunk; below these roosts most of the limbs were broken stubs with no needles, as is typical in Red Pine plantations. A well hidden Saw-whet Owl is nearly impossible to spot when it is high in a Red Pine. Furthermore, in the summer the evidence of a roost--wash and pellets--on or near the ground is erased rapidly by weather and insects, which makes it more difficult to identify a roost tree. For these reasons we believe that Saw-whet Owls probably roost in such tall trees more often than is indicated by the frequency with which they are found there. Hayward and Garton (1984) used radiotelemetry to locate Saw-whet Owl roosts and found Saw-whet Owls roosting as high as 7.3 m, with a mean height of 4.2 m (N=15). It took up to 45 minutes to find the owl after they had located the roosting tree, indicating how difficult Saw-whet Owls are to find when they choose high roosts.

At Mirror Lake Pine Barren Saw-whet Owls frequently roosted in dense 3-6 m tall Eastern Red Cedars that were scattered widely and singly across the open dry prairie or on the edges of Jack Pine clumps. Only the largest Red Cedars were chosen. Roosts tended to be less than 2 m high--at or lower than the widest point of the tree. The roost location ranged from near the trunk to near the tips of the branches, but was usually in the outer part of the foliage (mean=107 cm from the trunk, N=9).

Roosts in Jack Pines were in trees of all sizes, but most were in small trees in dense clumps. Some roosts were in large sprawling Jack Pines that had many limbs intersecting one another 1-4 m off the ground. Roost locations ranged from near the trunk to 2/3 of the way out on the branch, with the mean 53.2 cm from the trunk (N=36).

White Spruce roosts were generally 2-4 m high and close to the trunk of the tree (mean=27.4 cm, N=38). In general, these trees afford considerable cover from all directions and the plantations or dense forests are difficult to traverse. One plantation yielded pellets throughout the year and produced our only summer sighting of a Saw-whet Owl on 1 July. Many winter roosts were along a hiking-skiing trail that bisects the plantation. During the late spring and summer the owl seemed to choose more secluded roosts in the interior of the plantation. This may have resulted from our frequent visits to the area to collect pellets.

Roosts in Norway Spruces were all in fairly tall trees and were intermediate in height between White Spruces and Red Pines. The two highest roosts in Norway Spruces were in a tree at the edge of a plantation. Roosts tended to be close to the trunk in this species (mean=18 cm, N=4).

PELLET ANALYSIS

We collected 431 Saw-whet Owl pellets between 17 March and 17 December. Saw-whet Owl pellets are

very compact and are usually dark and moist when fresh. Typical pellets were 2.5-4.0 cm long and 1.3-1.7 cm wide (mean length= 3.05 cm, range=1.8-5.1 cm, N=344 unbroken pellets; mean width=1.54 cm, range=0.9-2.0 cm, N=396 pellets).

We analyzed 380 pellets, using Driver (1949), Jackson (1961), Glass (1973), and Burt and Grossenheider (1976) to identify the mammal skulls. Table 4 lists the prey items found in the pellets. There were 0.64 prey items per pellet, which agrees with the findings of Collins (1963) and Errington (1932) that Saw-whet Owls frequently cast two pellets per prey item eaten. Over 90% of prey individuals were rodents, and over 80% of the prey items were Peromyscus. Peromyscus has been the dominant prey in most studies of Saw-whet Owl diets, e.g. Errington (1932) and Graber (1962), in the midwest United States. Microtus was the second most important prey item. We also found a few Sorex and Blarina shrews, one Myotis bat, several small birds, and one cricket in the pellets. Terrill (1931) also found Myotis in the diet of Saw-whet Owls.

The Saw-whet Owl prey was heavily slanted toward woodland species. Over 90% of the Peromyscus identified were P. leucopus, a forest species; the rest were P. maniculatus, a field species. Microtus is an open country genus in our area, while Sorex cinereus is generally a forest species, Blarina brevicauda is ubiquitous, and Myotis likewise could be found almost anywhere. Excluding the one rodent, birds, and cricket, whose prime habitats are unknown since we couldn't identify them to species, about 188 prey individuals were forest-dwelling species, 37 were open-country species, and seven were widely

Table 4. Prey items found in 380 Saw-whet Owl pellets collected 17 March to 17 December

Prey Item	N individuals (%)
Mammals (95.9%)	
Rodents (90.9%)	
<u>Peromyscus</u> spp.	195 (80.2)
<u>P. leucopus</u>	121
<u>P. maniculatus</u>	8
unidentified <u>P.</u>	66
<u>Microtus</u> spp.	25 (10.3)
<u>M. pennsylvanicus</u>	17
<u>M. ochrogaster</u>	2
unidentified <u>M.</u>	6
unidentified rodent	1 (0.4)
Shrews (4.5%)	
<u>Blarina brevicauda</u>	6 (2.5)
<u>Sorex cinereus</u>	5 (2.1)
Bats (0.4%)	
<u>Myotis</u> spp.	1 (0.4)
Birds (3.7%)	
Finch spp.	2 (0.8)
unidentified Passerine	7 (2.9)
Insects (0.4%)	
cricket	1 (0.4)
Total	243 (100.0)

adapted species. Therefore, over 80% of the prey was gleaned from the forest floor. Saw-whet Owls that lived in more open Red Pine plantations or that roosted in Eastern Red Cedars in open parts of Mirror Lake Pine Barren took proportionately more open-country prey than their counterparts in denser White Spruce or Jack Pine stands. These Saw-whet Owls living in more open habitat took 40% Microtus and 51% Peromyscus versus the 5% Microtus and 85% Peromyscus for the Saw-whet Owls living in denser forests in the same region.

ACKNOWLEDGEMENTS

We are grateful to Ken Lange for sharing his great personal knowledge and helpful encouragement. We thank Lisa Hartman and Jim Harris for providing us with additional records of Saw-whet Owls. Douglas Trapp has also given us helpful information and encouragement.

LITERATURE CITED

- Brewster, W. 1925. The birds of the Lake Umbagog region of Maine. *Bulletin of the Museum of Comparative Zoology* 66: 215-402.
- Burt, W. H., and R. P. Grossenheider. 1976. A Field Guide to the Mammals. Houghton Mifflin Company, Boston.
- Catling, P. M. 1971. Spring migration of Saw-whet Owls at Toronto, Ontario. *Bird Banding* 42: 110-114.
- Collins, C. T. 1963. Notes on the feeding behavior, metabolism, and weight of the Saw-whet Owl. *Condor* 65: 528-530.
- Curtis, R. D. 1963a. Observation on the nesting of the Saw-whet Owl at the Rose Lake Wildlife Research Center. *Jack-Pine Warbler* 41: 110-112.
- Curtis, R. D. 1963b. Recent Saw-whet Owl nest, Crawford County, Mich. *Jack-Pine Warbler* 41: 133.
- Driver, E. C. 1949. Mammal remains in owl pellets. *American Midland Naturalist* 41:139-142.
- Druckenmiller, H. S. 1978. Environmental Impact Statement for the Proposed Ice Age National Scientific Reserve Master Plan, Wisconsin. Bureau of Parks and Recreation, Wisconsin Department of Natural Resources, Madison.
- Eckert, A. W., and K. E. Karalus. 1974. The Owls of North America (North of Mexico). Doubleday and Company, Inc., Garden City, New Jersey. pp. 56-65.
- Emlen, J. T. 1984. An observer-specific, full-season, strip-map method for censusing songbird communities. *Auk* 101: 730-740.
- Errington, P. L. 1932. Food habits of southern Wisconsin raptors, part I. Owls. *Condor* 34: 176-186.
- Follen, D. G. Sr. 1981. Wisconsin breeding and breeding period records of Saw-whet Owls. *Passenger Pigeon* 43: 113-116.
- Follen, D. G. Sr. 1982. Additional breeding and breeding period records of Saw-whet Owls in Wisconsin. *Passenger Pigeon* 44: 71.
- Follen, D. G. Sr., and J. C. Haug. 1981. Saw-whet Owl nest in Wood Duck box. *Passenger Pigeon* 43: 47-48.
- Forbes, J. E., and D. W. Warner. 1974. Behavior of a radio-tagged Saw-whet Owl. *Auk* 91: 783-795.
- Glass, B. P. 1973. A Key to the Skulls of North American Mammals. Department of Zoology, Oklahoma State University, Stillwater.
- Graber, R. R. 1962. Food and oxygen consumption in three species of owls (Strigidae). *Condor* 64: 473-487.
- Hayward, G. D. 1983. Resource partitioning among six forest owls in the River of No Return Wilderness, Idaho. M.S. Thesis, University of Idaho, Moscow.
- Hayward, G. D., and Edward O. Garton. 1984. Roost habitat selection by three small forest owls. *Wilson Bulletin* 96: 690-692.
- Jackson, H. H. T. 1961. Mammals of Wisconsin. The University of Wisconsin Press, Madison.
- Johnson, R. R., L. T. Haight, and J. M. Simpson. 1979. Owl populations and species status in the southwestern United States. pp. 40-59 in P. P. Schaeffer and S. M. Ehlers, eds. *Proceedings of the Symposium on Owls of the West: Their Ecology and Conservation*. National Audubon Society Western Education Center, Tiburon, California.
- Mossman, M. J., and K. I. Lange. 1982. Breeding birds of the Baraboo Hills, Wisconsin: Their History, Distribution, and Ecology. Department of Natural Resources and Wisconsin Society for Ornithology, Madison, Wisconsin.
- Mumford, R. E., and R. L. Zusi. 1958. Notes on the movements, territory, and habitat of wintering Saw-whet Owls. *Wilson Bulletin* 70: 188-191.
- Ralph, C. J. 1981. Appendix I. Terminology used in estimating numbers of birds. *Studies in Avian Biology* no. 6: 577-578.
- Savage, T. 1965. Recent observations of the Saw-whet Owl in G.S.M.N.P. *Migrant* 36: 15-16.
- Simpson, M. B. Jr. 1972. The Saw-whet Owl population of North Carolina's southern Great Balsam Mountains. *Chat* 36: 39-47.
- Swengel, A. B., and S. R. Swengel. 1986. An auditory census of Northern Saw-whet Owls (Aegolius acadicus) in Sauk County, Wisconsin. *Passenger Pigeon* 48:119-121.
- Terrill, L. McI. 1931. Nesting of the Saw-whet Owl (Cryptoglaux acadica acadica) in the Montreal District. *Auk* 48: 168-174.
- Vanderschaegen, P. 1981. Where are the Saw-whet Owls? *Passenger Pigeon* 43: 48-49.
- Wilson, K. A. 1938. Owl studies at Ann Arbor, Michigan. *Auk* 55: 187-197.

Remigial Molt in Fall Migrant Long-Eared and Northern Saw-Whet Owls'

David L. Evans and Robert N. Rosenfield²

Abstract.--Netting operations at the Hawk Ridge Nature Reserve, Duluth, Minnesota resulted in the capture of 1,090 Long-eared Owls from 1976-86 and 2,639 Northern Saw-whet Owls from 1980-86. Adults and juveniles can be separated by the presence or absence of (1) 2 generations of remiges and/or (2) sequentially grown remiges, which are characterized by a pink color on the undersurface that fades with time. The proportion of adult Long-eared Owls with completed remigial molt varied from year to year, ostensibly in relation to prey abundance. In contrast, virtually all adult Saw-whet Owls had retained remiges from the previous year, with 3 basic molt patterns that appeared to correspond with different age classes.

INTRODUCTION

Patterns of molt provide a basis for ageing many species of birds for banding (Anonymous 1977). Previous studies on the molt patterns of Long-eared Owls (*Asio otus*) mainly have been concerned with captive birds (Haarhaus 1983, Wijnandts 1984) and a few individuals encountered in the wild at various times of year (Stresemann and Stresemann 1966). We are not aware of published data on molt patterns of remiges in Northern Saw-Whet Owls (*Aegolius acadicus*). Mueller and Berger (1967) aged adult Saw-whet Owls by the presence of 2 generations of remiges, but at that time it was not known whether they resulted from an interrupted molt or an incomplete annual molt (J. Sheppard, Bird Banding Lab., pers. comm.). Subsequent studies also have relied on the presence of 2 generations of remiges in ageing saw-whets (Evans 1975, Sheppard and Klimkiewicz 1976, Anonymous 1977, Weir et al. 1980, Buckholtz et al. 1984). Weir et al. (1980) suggested that the 2 generations arise from an interrupted molt, while Buckholtz et al. (1984) attributed it to a

partial postbreeding remex molt. In this paper we present molt patterns in fall migrant Long-eared Owls captured from 1976 to 1986 and in Saw-whet Owls captured from 1980 to 1986. We also discuss the patterns' relationship to ageing owls and ecological factors that may influence observed patterns.

METHODS

Trapping by mist net ('CTX', Northeastern Bird-Banding Assoc.) was conducted nightly from mid September to mid November at the Hawk Ridge Research Station, Hawk Ridge Nature Reserve, Duluth, Minnesota. The study area, net placement, and owl capture techniques are described in Evans (1980).

In addition to banding and taking weight, wing, and tail measurements, we recorded the molt of right wing remiges and rectrices for all adult owls. Long-eared Owls could not be reliably sexed, although we did assign sex based on underwing coloration -- males being paler and less buffy than females. We also had difficulty sexing Saw-whet Owls. Measurement criteria presented by Sheppard and Klimkiewicz (1976) and Buckholtz et al. (1984), when applied to our captures, resulted in a sex ratio heavily skewed toward males and we have little confidence in the applicability of those criteria to the Saw-whet population migrating through Duluth. Beginning in 1977, we applied permanent green dye (Sanford's Marker) to remiges of all Saw-whet Owls to evaluate the age

¹Paper presented at the symposium, Biology and Conservation of Northern Forest Owls, Feb. 3-7, 1987, Winnipeg, Manitoba. USDA Forest Service General Technical Report RM-142.

²David L. Evans, Hawk Ridge Nature Reserve, 2928 Greysolon Rd., Duluth, Minn. 55812 and Robert N. Rosenfield, Dept. of Zoology, North Dakota State Univ., Fargo, ND 58105.

status of retained feathers in birds recaptured in subsequent years.

RESULTS AND DISCUSSION

Long-eared Owls

We captured 1,090 Long-eared Owls, of which 394 (36.1%) were adults (table 1). The yearly juvenile/adult ratio ranged from 0.5 to 4.3, with an overall ratio of 1.8. Of the adult owls, 194 (49.2%) had completed their molt and had only 1 generation of remiges; these were aged by the presence of pink color on the undersurface of the remiges. This pink wash is most apparent on newly grown feathers and fades over a period of several months. Since adult primaries grow sequentially from P1 to P10 (Wijnandts 1984) the pink wash increases in intensity toward P10, in contrast to juveniles, in which the pink wash is well faded and uniformly colored. There usually is marked contrast in pink wash between S4 and S5 (the molt center), which is often helpful in ageing some birds (probably females) whose buffier underwing color tends to obscure the pink wash in the primaries. Of the adult owls, 200 (50.8%) still retained old feathers from the previous year (the molt column in table 1 totals 197 because molt records were lost for 3 owls, 1 each in 1978, 1981, and 1984). Table 2 presents the total number of old feathers at each remex position for owls with molt (no owls had old rectrices). Adult owls with retained old feathers had a mean of 0.1 old

primaries and 4.1 old secondaries. Rounding these averages off to the nearest whole feather and applying them to the highest frequencies in table 2 to identify locations, we derived a 'generalized composite' of a typical adult long-ear with incomplete molt (fig. 1). Wijnandts (1984) found that primary molt proceeded descendently from P1 and secondary molt proceeded descendently from molt centers at S1 and S5 and ascendently and descendently from a third molt center at S11. Thus, the last secondaries to be molted typically were S4, S7, and S8. In general, our observations are in agreement; however, we observed a number of birds that had begun molt at S2 or S3, retaining old feathers only at S1 (6) or S1-2 (9). Eliminating these birds from the frequencies in table 2 resulted in a 'generalized composite' that more accurately reflects the typical owl with retained feathers observed at Duluth in the autumn (fig. 2). The frequencies of old feathers at the molt foci (S1, 5, and 11, table 2) suggest that molt is more likely to be initiated at S5 and 11 than at S1, perhaps reflecting stronger hormonal influence. Indeed, it was not uncommon for the molt center at S1 to remain inactive,

Table 1.--Yearly numbers of Long-eared Owls captured at Duluth, Minnesota, 1976 - 1980, and number of adults with molt.

Year	Juvenile	Adult	Molt	%
1976	95	42	19	45
1977	49	26	17	65
1978	111	60	56	93
1979	56	23	18	78
1980	96	37	11	30
1981	88	71	22	31
1982	30	61	20	33
1983	17	13	11	85
1984	56	13	5	38
1985	26	8	2	25
1986	72	40	16	40
Total	696	394	197	50

Table 2.--Total number of old feathers at each feather position in the right primary (RP) and right secondary (RS) of 197 adult Long-eared Owls with molt.

RP	1	1	1	1				1	3	5			
	1	2	3	4	5	6	7	8	9	10	11	12	
RS	106	103	108	133	38	72	112	96	4	0	7	0	0

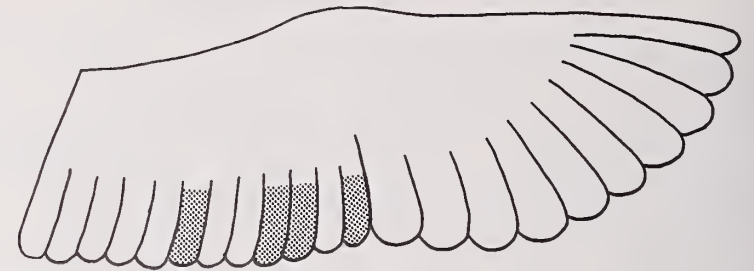

Figure 1.--Original generalized composite derived for a typical adult Long-eared Owl with molt (old feathers shaded).

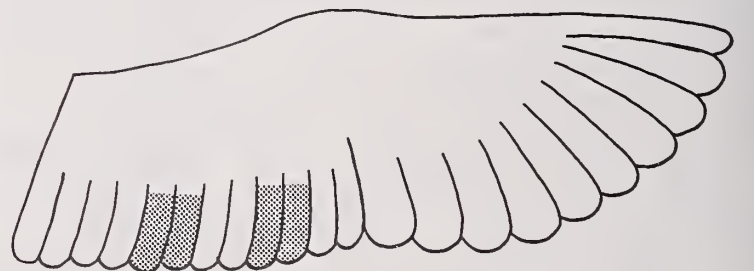

Figure 2.--Revised generalized composite derived for a typical adult Long-eared Owl with molt (old feathers shaded).

resulting in an otherwise cleanly molted bird with old feathers at S1-4.

Almost all Long-eared Owls had completed primary molt. Only 5 of the 197 owls with retained feathers had not finished molting their primaries. Three of these birds occurred in 1978, which had the highest yearly proportion of owls with molt. One apparently aberrant individual had only replaced P5-7, had S1-10 old, and had all 12 rectrices just emerging from sheath. The remaining 4 had a pattern consistent with descendent primary molt, with P9-10 old (table 2). Of the owls with retained feathers, 84 (42.6%) also had actively growing feathers. These included a total of 107 primaries (predominantly P9-10) and 68 secondaries, which were invariably in a sequence consistent with the molting pattern described by Wijnandts (1984) and observed in this study. The mean length of growing feathers (recorded in tenths) was 8.2 for primaries and 8.0 for secondaries; only 12 of 107 primaries and 5 of 68 secondaries were less than 7/10 grown. Thus it appears, for the most part, that active molting ceases with the onset of migration. We captured only one owl that had two generations of old feathers. We conclude that the old, retained feathers observed in fall migrant long-ears are the result of an interrupted molt, which is completed sometime after migration.

The proportion of adult long-ears that had not completed their molt varied considerably among years, from a high of 93% to a low of 25% (table 1). We feel that prey availability during the molting period may explain the variation observed. With peaks in 1978 and 1983 and lows in 1980 and 1985, the proportion of incompletely molted owls appears to vary in a regular fashion, perhaps in association with fluctuations in microtine prey. However, we found no correlation between the proportion of owls with retained feathers and the mean yearly capture weight of juveniles, adults, completely molted adults, or incompletely molted adults, although it did approach significance for adults ($r = -0.56$, 9 d.f., $P > 0.05$) and for incompletely molted adults ($r = -0.56$, 9 d.f., $P > 0.05$). With the caveat that relatively minor changes in the male/female ratio could have a substantial effect on the yearly mean capture weight, there appears to be no substantial relationship between the proportion of incompletely molted owls and capture weight. In 6 of the 11 years, mean capture weight of cleanly molted owls was less than that of incompletely molted owls, although overall it was slightly higher. To what extent the sex ratio affected mean capture weight is unknown and precludes further analysis on the relationship between the proportion of cleanly molted owls and food supply.

Saw-whet Owls

We captured 2,639 Saw-whet Owls, of which 1,463 (55.4%) were adults (table 3). The yearly juvenile/adult ratio ranged from 0.5 to 1.5, with an overall ratio of 0.8. Only 8 adults (0.5%) had completed their molt and had one generation of remiges (group E, table 3). As in the Long-eared Owls, these were aged by the pink wash on the undersurface of newly replaced remiges, which was most apparent on the outer primaries (P8-10) and at various locations in the secondaries, depending on the molt pattern involved. Care was taken in this category not to include juveniles, which often exhibit the pink wash uniformly across their greater underwing coverts as a result of their recent postjuvinal body molt. The remaining 1,455 adults had 2, and sometimes 3, generations of feathers. Considering only the 2 most recent generations of feathers, we used the molt records of individual owls to delineate 3 basic groups. A 4th group consisted of birds that could not be assigned to the above groups. In practice, placement of an owl into 1 of the 3 basic groups occasionally involved some judgement, particularly in regard to the presence of 1 and sometimes 2 'atypical' (i.e., new instead of old) feathers in an otherwise clearly apparent pattern.

Group A was by far the largest with 827 (56.5%) owls and had a pattern consisting of a solid block of old inner primaries and secondaries. Table 4 presents the total number of old feathers at each remex position for group A. Adult owls in group A had a mean of 4.2 old primaries and 3.9 old secondaries. Rounding these averages off to the nearest whole feather and applying them to the highest frequencies in table 4, we derived a generalized composite of a typical saw-whet in group A (fig. 3). This composite, with P1-4 and S1-4 old, was the most common configuration in group A (table 5).

Group B was the smallest of the 3 groups with 202 (13.8%) owls and had a

Table 3.--Yearly numbers of Saw-whet Owls captured at Duluth, Minnesota, 1980 - 1986, and number of adults in each molt pattern group.

Year	Juvenile	Adult					Total
		A	B	C	D	E	
1980	187	76	9	33	2	1	308
1981	158	165	33	45	5	3	409
1982	145	117	19	64	1	3	349
1983	61	65	29	23	3	0	181
1984	336	190	70	143	6	0	745
1985	140	106	19	51	4	0	320
1986	149	108	23	40	6	1	327
Total	1176	827	202	399	27	8	2639

Table 4.--Total number of old feathers at each feather position in the right primary (RP) and right secondary (RS) of adult Saw-whet Owls in group A, B, and C.

A	RP	826	820	777	616	357	83	14					
		1	2	3	4	5	6	7	8	9	10	11	12
	RS	812	699	641	571	428	274	194	102	45	7	1	
B	RP	4	24	59	114	115	81	54	38	18	9		
		1	2	3	4	5	6	7	8	9	10	11	12
	RS	38	88	104	102	122	126	120	96	57	29	12	5
C	RP	304	259	151	132	151	189	172	103	51	25		
		1	2	3	4	5	6	7	8	9	10	11	12
	RS	201	152	152	156	152	192	205	205	177	104	40	30

pattern consisting of a solid block of old feathers in the mid primaries and another solid block of old feathers in the mid secondaries (table 4). Owls in group B had a mean of 2.6 old primaries and 4.4 old secondaries. Rounding these averages off to the nearest whole feather and applying them to the highest frequencies in table 4, we arrived at a generalized composite of a typical saw-whet in group B (fig. 4). There was considerable variation in the location of the respective primary and secondary blocks as can be inferred from table 4 but the respective sites were invariably consistent between primaries and secondaries (i.e., old blocks nearer the inner primaries corresponded with old blocks nearer the inner secondaries). Owing to this variation in location of old blocks there was a slight anomaly in total number of feathers between S3 and S4 in terms of portraying a solid block of secondaries. Our composite (fig. 4) includes only S4, although the actual mean of old secondaries (4.4) shows that a composite would also include S3 in about 40% of the owls.

Group C, with 399 (27.3%) owls, exhibited the widest variation in its basic pattern. It is characterized by 2, and sometimes 3, discrete blocks of old feathers in both primaries and secondaries. One block is invariably centered on the inner primaries and secondaries (similar to group A) but the position of the remaining

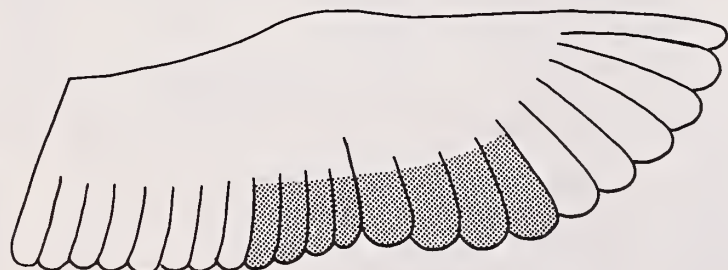

Figure 3.--Generalized composite derived for a typical adult Saw-whet Owl with type A molt (old feathers shaded).

Table 5.--Frequency of adult Saw-whet Owls at each right primary/secondary combination of retained old feathers in Group A.

RP	0	1	2	3	4	5	6	7	8	9	
RS 0		3	10	2							
1		2	17	73	11						
2			4	26	26	2					
3	1	1		19	44	4	1				
4			2	25	78	37	1				
5				7	61	76	8	2			
6				2	21	45	11	1			
7				4	8	66	14				
8					8	27	18	4			
9				3	2	12	15	4	2		
10						3	2	1			
11						1					
12											

block(s) was variable, as evidenced by the frequencies of total old feathers at each feather position (table 4). Owls in group C had a mean of 3.9 old primaries and 4.4 old secondaries; rounding to the nearest whole feather and applying to the frequencies in table 4, we derived the generalized composite shown in fig. 5. As in group B, the discrete blocks of old feathers were generally in comparable positions in the primaries and secondaries (i.e., a block centered at P7 had a corresponding secondary block centered at S7).

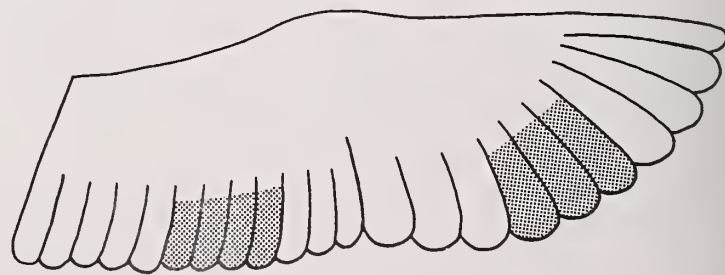

Figure 4.-- Generalized composite derived for a typical adult Saw-whet Owl with type B molt (old feathers shaded).

Group D, consisting of 27 (1.8%) owls, was composed of birds with virtually all old or all new feathers (owls with only one or two old feathers at P1 or S1 were included in group A).

As in the Long-eared Owls, some Saw-whet Owls had actively growing feathers when captured. Of the adults, 117 (8.0%) had growing feathers. These birds were evenly distributed among all groups. Growing feathers included a total of 158 primaries and 55 secondaries. Actively growing primaries invariably involved P9-10. The mean length of growing feathers (recorded in tenths) was 8.8 for primaries and 8.3 for secondaries, indicating a cessation of feather replacement with the onset of migration.

Some saw-whets had 3 generations of feathers as a result of some feathers being retained through 2 molt cycles (3 years). These occurred only in groups B, with 47 (23.3%) owls, and C, with 16 (4.0%) owls. In group B owls, the very old feathers were always found at the inner primaries and secondaries, in conformance with the Group A pattern. In group C owls, 8 had very old feathers conforming to the group A pattern and the remaining 8 showed no evident pattern.

The significance of the 3 major molt patterns was elucidated by the recapture of color marked saw-whets in subsequent years. All 4 saw-whets banded as juveniles and recaptured a year later exhibited the group A pattern and we believe that most, if not all, yearling saw-whets undergoing their first remigial molt become type A. We had no recaptures of owls known to be 2 years old but suspect that they may represent the group B pattern. Given the strong tendency for annual replacement of inner secondaries and outer primaries (see table 4), the concurrent replacement of the old group A feathers would result in a type B pattern. The relatively large proportion of group B owls retaining very old feathers, all of which were in the type A pattern, would lend support to the association between 2-year-olds and the type B pattern. Alternatively, the type B pattern may merely be a variation of the type C pattern (see below). We believe the type C pattern

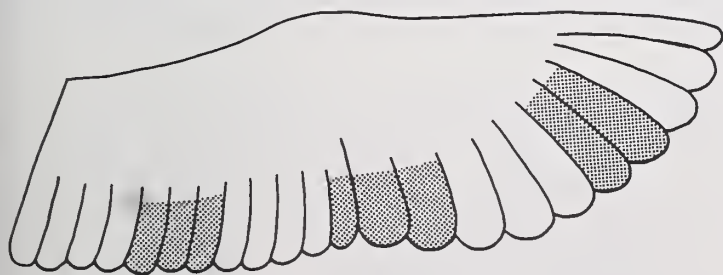

Figure 5.--Generalized composite derived for a typical adult Saw-whet Owl with type C molt (old feathers shaded).

represents owls ≥ 3 years old. Four of 8 owls known to be at least 3 years old did exhibit the type C pattern. However, not all owls at least 3 years old exhibited the type C pattern. Of the remaining 4 owls, 2 had a type A pattern, 1 was type B, and the 4th had only 1 old feather, or type D. Hypothetically, if we were to take the type C pattern (fig. 5) and eliminate (replace by molt) one of the two discrete (associated primary/secondary) blocks, we would derive a type A pattern by eliminating the outer block. If the inner primary/secondary block were eliminated, a type B pattern would result. At present we can confirm the existence of type A and B in owls at least 3 years old, but whether they are initially derived from a type C pattern is unknown.

The recapture of color marked saw-whets also provided some information on the progression of molt patterns from year to year. As mentioned above, the 4 owls originally captured as juveniles exhibited the type A pattern when retrapped 1 year later. One additional owl was recaptured a year later. It initially had a type C pattern and again was type C a year later, but had replaced the previous year's old feathers and retained the previous year's new feathers, so aside from the annual replacement of outer primaries and inner secondaries, it exhibited a perfect reversal of old and new feathers in the second year (figure 6). Six owls were recaptured 2 years after initial capture but not the intervening year; 2 owls exhibited a pattern progression of A-?-A, and the remaining 4 owls exhibited A-?-C, A-?-D, B-?-B, and C-?-C. We had 2 recoveries of owls 6 years later. One, originally captured as a juvenile, had a type C pattern. The other had similar type C patterns at both encounters.

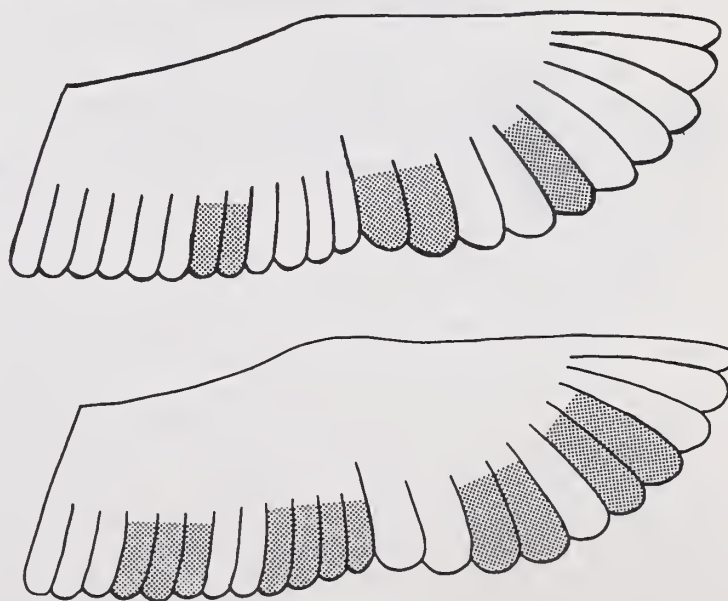

Figure 6.--Molt in an adult Saw-whet Owl captured in 1980 (top) and in 1981 (bottom) with type C patterns (old feathers shaded).

The wide variability in the 3 basic molt patterns (table 4) suggests that, as a species, the Saw-whet Owl does not exhibit molt foci in consistent locations, as is generally true in other avian species. As individuals, owls do show a tendency to retain molt foci at specific locations even though some foci are activated only in alternate years. Molt foci associated with replacement of outer primaries and inner secondaries (as well as rectrices) are activated every year. Of the 6 owls recaptured 2 years later, 2 had identical molts (A-A), one was virtually identical (B-B, with retained very old feathers at P1), and one (C-C) was roughly similar. The molt patterns of the 6 year recovery were also very similar.

Saw-whet Owls in this study retained, on average, about 35% of their remiges for 2 years. Replacement of the outer primaries, inner secondaries, and rectrices typically occurs each year. These feather tracts are in areas exposed to greater wear and abrasion than remiges in the middle of the wing. Primary feather molt in Boreal Owls (*A. funereus*) appears similar (Glutz and Bauer 1980), although retention of very old inner primaries appears to be common in 3-year-old birds and annual replacement of outer primaries is perhaps less frequent. Of 6 Boreal Owls captured during this study, 3 were type A, 2 were type C (with outer primaries and/or secondaries not replaced), and 1 did not fit our classification. The genus *Aegolius* appears unique, considering body size, in that virtually all birds have an incomplete annual molt. The retention of remiges may represent a savings in energy expenditure that is better utilized elsewhere, such as reproductive output.

ACKNOWLEDGEMENTS

We thank J. Goin, T. Wiens, and the many volunteers who aided in data collection. This study was partially funded by private donations to the Friends

of Hawk Ridge. We thank J. Bielefeldt, M. Evans, and C. R. Sindelar for their constructive criticisms of the manuscript and M. Myers for translating pertinent portions of German papers.

LITERATURE CITED

- Anonymous. 1977. North American bird banding techniques. Vol. 2, Part 6. Ageing and sexing. U. S. Fish and Wildl. Serv. and Can. Wildl. Serv.
- Buckholtz, P. G., M. H. Edwards, B. G. Ong, and R. D. Weir. 1984. Differences by age and sex in the size of Saw-whet Owls. *J. Field Ornithol.* 55: 204-213.
- Evans, D. L. 1975. Fall owl migration at Duluth, Minnesota. *Loon* 47: 56-58.
- Evans, D. L. 1980. Multivariate analyses of weather and fall migration of Saw-whet Owls at Duluth, Minnesota. M. S. thesis, North Dakota State University, Fargo. 49 pp.
- Glutz von Blotzheim, U. N., and K. Bauer. 1980. *Handbuch der Vogel Mitteleuropas*. Vol. 9. Akademische Verlagsgesellschaft, Wiesbaden.
- Haarhaus, D. 1983. Die Grossgefiedermauser palaearktischer Eulen in Gefangenschaft. *Beitr. Vogelk.* 29: 89-102.
- Mueller, H. C., and D. D. Berger. 1967. Observations on migrating Saw-whet Owls. *Bird-Banding* 38: 120-125.
- Sheppard, J. M., and M. K. Klimkiewicz. 1976. An update to Wood's bird bander's guide. *North Am. Bird Bander* 1: 25-27.
- Stresemann, E., and V. Stresemann. 1966. Die Mauser der Vogel. *J. fur Ornithol.* 107, Suppl.
- Weir, R. D., F. Cooke, M. H. Edwards, and R. B. Stewart. 1980. Fall migration of Saw-whet Owls at Prince Edward Point, Ontario. *Wilson Bull.* 92: 475-488.
- Wijnandts, H. 1984. Ecological energetics of the Long-eared Owl (*Asio otus*). *Ardea* 72: 1-92.

Dispersal and Mortality of Juvenile Eagle Owls Released from Captivity in Southeast Norway as Revealed by Radio Telemetry¹

Runar S. Larsen, Geir A. Sonerud,
and Ole H. Stensrud²

Abstract.--Of 9 captive juvenile Eagle Owls released and radio tracked autumn 1986, 7 died within 3 months after being released; 4 due to electrocution by power lines, 1 due to wing injury, 1 due to hunting, and 1 due to starvation. The 7 birds that died had dispersed from 1.2-9.9 km, while the two that were still alive by mid-January 1987 had dispersed 33 km and 62 km.

INTRODUCTION

The breeding population of Eagle Owl *Bubo bubo* in southeast Norway has declined seriously since about 1950, and by 1975 was almost vanished in the lowlands (Fremming 1987). In order to restore this population a total of 325 juvenile Eagle Owls hatched in captivity have been released in southeast Norway each autumn since 1978. From ringing recoveries of dead specimen some knowledge has been gained about the dispersal distance, mortality rate, and mortality causes of these Eagle Owls. However, nothing is known about their habitat selection, home range size, and prey selection. Therefore, habitat management as part of the effort to restore the Eagle Owl population has so far been impossible to conduct.

Telemetry has been employed to reveal the secret behavior of nocturnal owls for more than two decades (Nicholls and Warner 1972, Forbes and Warner 1974). It has mostly been used to study habitat selection and home range size (e.g. Nicholls and Warner 1972, Forbes and Warner 1974, Bondrup-Nielsen 1978, Hayward and Garton 1984, Smith and Gilbert 1984), and more rarely to study nocturnal hunting behavior (Nilsson 1978, Wijnandts 1984, Sonerud et al. 1986). Studies on juvenile dispersal in owls by use of telemetry are few. However, one such study was conducted on Eagle Owls in Sweden (Arnkvist et al. 1984), but comprised only 3 birds with very few data on each. In order to obtain more detailed informat-

ion on dispersal and mortality than obtained by ringing recoveries, and to obtain general information on home range size and selection of habitat and prey, we initiated a two-year study on radio-equipped juvenile Eagle Owls released from captivity. Here we report preliminary results on dispersal, mortality, and habitat selection from the first year of the study.

STUDY AREA AND METHODS

The Eagle Owls were released from Blokkemyr Eagle Owl farm in Østfold County, southeast Norway (59°11'N, 11°34'E). The study area has so far spread into Østfold and Akershus counties in southeast Norway and Göteborg & Bohus county in southwest Sweden. It is situated in the boreo-nemorale zone (sensu Nordiska Ministerrådet 1984), is fairly flat with elevations from 0-350 m, and consists of farmland interspersed with mixed coniferous-broadleaf forest.

Ten juveniles (5 females and 5 males) were equipped with a 40 g radio-transmitter (Biotrack, England) attached as a backpack, and released between September 5 - October 12 1986 (fig. 1). The birds were primarily localized from ground by cross-triangulation using a portable receiver (Televilt, Sweden) and a hand-held 4-element yagi-antennae. Cross-triangulation during daytime proceeded until the bird was sighted. The habitat it was perched in, as well as any prey or remnants thereof, were determined. If the bird was flushed, the base of its perch was checked for pellets. Nocturnal locations were determined by radio bearings alone, and the corresponding habitat determined from a map. When a bird was impossible to localize from ground, tracking was performed from aircraft. In this way, two out of three birds initially lost by ground tracking were found. All positions of localized birds were plotted on maps with scale 1:50,000. In addition, positions of localized birds within 4

¹Paper presented at the symposium, Biology and Conservation of Northern Forest Owls, Feb. 3-7, 1987, Winnipeg, Manitoba. USDA Forest Service General Technical Report RM-142.

²Runar S. Larsen is Graduate Student and Geir A. Sonerud is Research Associate, Department of Biology, Division of Zoology, University of Oslo, Oslo, Norway. Ole H. Stensrud is environmental engineer, Saugbruksforeningen, Halden, Norway.



Figure 1.--Eagle Owl M3 at roost near the release site. Photography by R.S. Larsen.

km of the release site were plotted on maps with scale 1:10,000.

RESULTS

Dispersal and mortality

During the first week after release, the Eagle Owls moved around within 4 km of the release site. Between 6-9 days after release four of them died due to electrocution by power lines 1.2 to 1.6 km from the release site (table 1). Another was found with a serious wing injury, probably due to contact with power lines, 2.8 km from the release site, and was killed (table 1). The other five left this area 7-13 days after release. Two dispersed more than 10 km. These two travelled fast for about two weeks after release (fig. 2), and then settled 5-6 weeks after release (figs. 2 and 3). Of the three remaining birds, one was found alive but starving 9.9 km from the release site 16 days after release. It was kept in an aviary at the release site and fed for a week before being released again. It then stayed around the release site for six weeks,

Table 1.--Date of release and recovery, mortality factor, distance dispersed, and status per January 15 1987 for 10 juvenile Eagle Owls (F=female, M=male) released with radio-transmitters in southeast Norway during autumn 1986.

Owl	Date of		Mortality factor	Distance Dispersed (km)
	Release	Recovery		
F1	Sept. 5	Sept. 13	Electrocution	1.5
M1	" 5	" 14	"	1.3
F2	" 5	" 21		19.9
"	" 28	Nov. 23	Hunting	3.9
M2	" 21	Sept. 28	Electrocution	1.2
M3	" 21	Oct. 4	Wing injury	2.8
M4	" 21	-		2>8.0
F3	" 21	Oct. 27		333
"	Nov. 15	-		33
F4	Sept. 28	Jan. 10	Starvation	46.5
M5	Oct. 5	-		62
F5	" 12	Oct. 18	Electrocution	1.6

¹ Captured in poor condition and kept in aviary with unlimited food availability before new release at the original release site.

² Radio contact lost after October 1.

³ Captured with an eye injury and kept in aviary with medical care before new release at the capture site.

⁴ Died between November 16 and December 22.

taking food (dead chickens) at the aviary, until being killed, probably by humans, 3.9 km from the release site. Another bird settled in an area 5-8 km from the release site, and died due to starvation between 7-12 weeks after release. The last bird was lost after 10 days when it had dispersed at least 8 km from the release site (table 1).

For the 9 Eagle Owls that we managed to follow, dispersal distance varied from 1.2-62 km, with an average of 13 km and a median of 2.8 km (table 1). Dispersal distance did not differ between the sexes (table 1; $U=15$, $p>0.2$, Wilcoxon two-sample test, two-tailed (Sokal and Rohlf 1969)). All the 5 birds that dispersed longer than the median distance moved out in the 135° sector between southwest and north (fig. 3).

Of the 9 Eagle Owls that we managed to follow, seven died within 12 weeks after the release (78%). Of these, four (57%) were killed by electrocution, one due to wing injury, one by humans and one by starvation. The four electrocuted ones were all found within 3 m from power poles, and so were probably killed while entering or leaving a power pole, using it as a hunting perch. There was no difference in longevity between the sexes (table 1; $U=19.5$, $p>0.2$, Wilcoxon two-sample test, two-tailed).

Habitat and prey.

For the 2 Eagle Owls that dispersed longer than 10 km, we compared the habitat used with

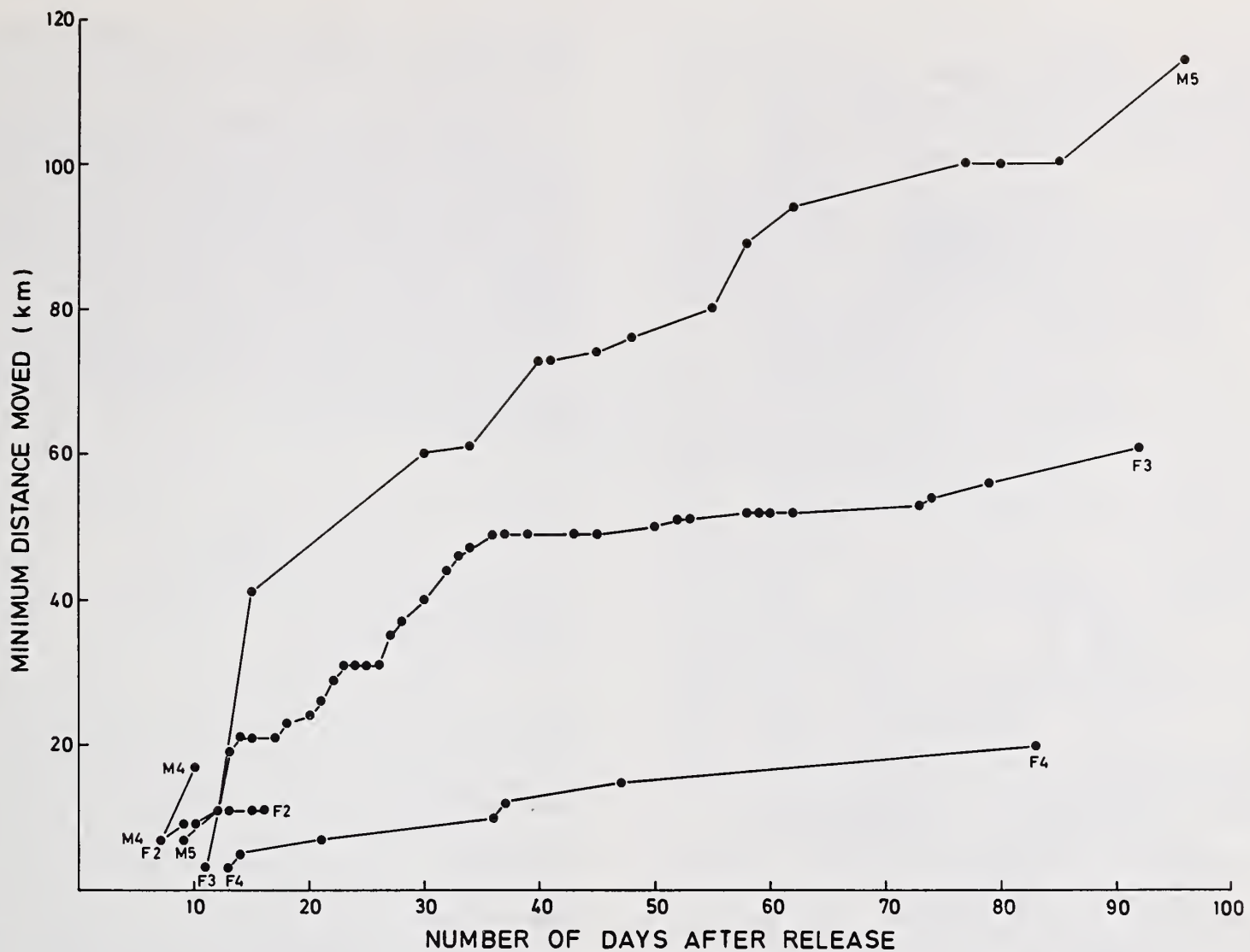

Figure 2.--Minimum distance moved in relation to time since release for the five radio-equipped juvenile Eagle Owls that dispersed farther than the median dispersal distance for all ten individuals. For more information see table 1.

that available. Both owls almost always perched in a tree or on the ground under one. The 30 relocalizations of F3 were more often situated within 200 m off water, i.e. lakes or sea, than expected by random movement ($\chi^2=18.83$, $p<0.001$), less often than expected within 200 m off cultivated fields or farmland ($\chi^2=4.97$, $p<0.05$), and as often as expected within 200 m off farm buildings, houses or cottages ($\chi^2=2.33$, $p>0.1$). The 10 relocalizations of M5 were distributed randomly with respect to proximity of both water, farmland and buildings ($p>0.1$ for all). However, 8 of the 10 relocalizations were within 200 m of farmland.

Only the two individuals that dispersed more than 10 km were observed with prey. F3 killed a Cat *Felis silvestris catus*, a Mink *Mustela vison*, and an unidentified medium-sized mammal, probably a Squirrel *Sciurus vulgaris*. M5 killed 3 Hooded Crows *Corvus corone cornix* and a Hare *Lepus timidus*.

DISCUSSION

Dispersal

The recorded dispersal of the radio-equipped Eagle Owls (range 1.2-62 km, average 13 km, and median 2.8 km) is somewhat less than the dispersal found for ringed birds released from 1978-85, which ranged 0-354 km ($n=67$) with an average of 33 km and a median of 10 km (R.S. Larsen, unpubl.). This difference may have been negligible if we had managed to keep contact with the tenth bird, which probably dispersed out of the study area. Juvenile Eagle Owls released from captivity in Switzerland dispersed 0-400 km ($n=53$) with an average of 25 km (Glutz von Blotzheim and Bauer 1980). Hence, the results derived from recoveries of ringed released juveniles in south-east Norway and Switzerland agree well.

The direction of the dispersal of the five radio-equipped Eagle Owls that dispersed longer

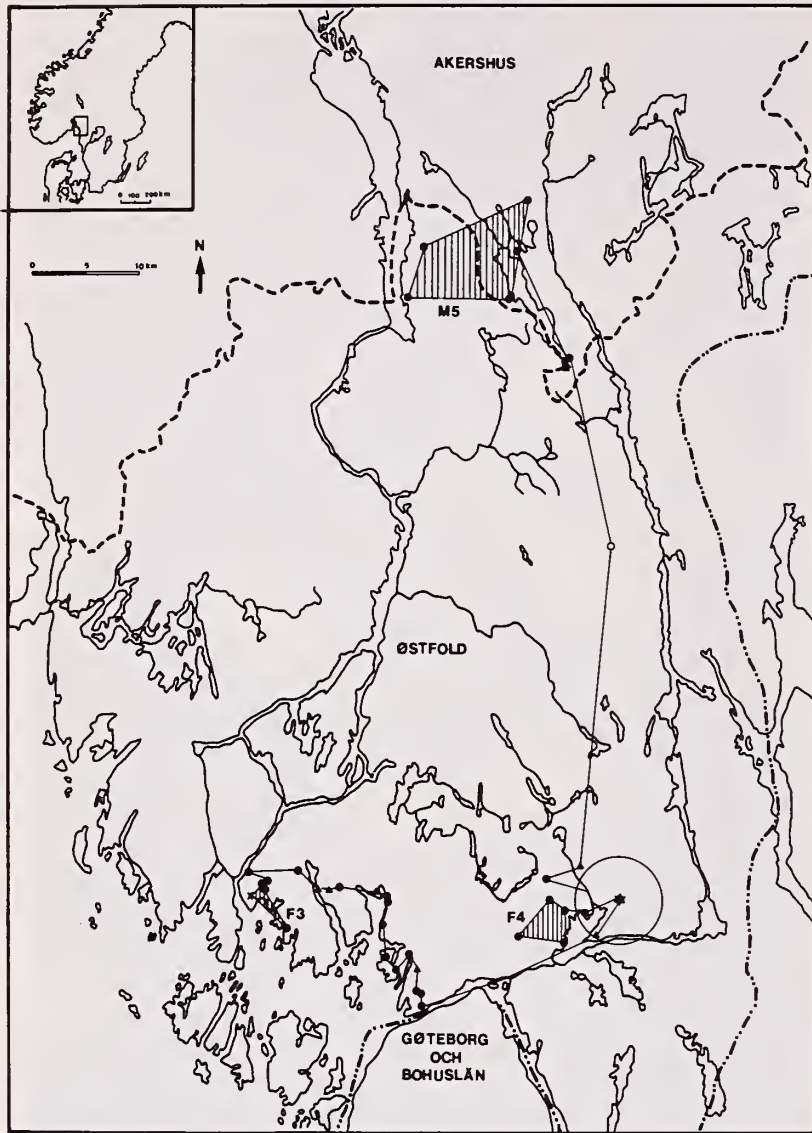

Figure 3.--Dispersal patterns of the three radio-equipped juvenile Eagle Owls that were tracked for more than 1 month. The asterisk denotes the release site, filled circles denote exact relocalizations from ground, open circles approximate relocalizations from air, open triangles approximate relocalizations from ground, and crossing denotes site of capture and new release after medical treatment of eye injury. Hatched areas denote home ranges. For more information see table 1.

than the median value was non-random, with a bias towards following natural guiding lines as lake and sea shores, and valleys with farmland, while avoiding larger areas of coniferous forest. On the other hand, recoveries of Eagle Owls banded as nestlings in the wild in Sweden were random with respect to direction (Olsson 1979), but the pooling of recoveries from a great number of nests may have swamped any direction biases from single nests.

Mortality

Within 12 weeks after release 78% of the radio-equipped juvenile Eagle Owls were dead. For birds ringed from 1978-85 in southeast Norway, 76% (n=66) died during the first 12 weeks (R.S. Larsen, unpubl.). Hence, mortality esti-

mates from radio tracking and ringing agree well.

Electrocution by power lines caused 57% of the recorded mortality of the radio-equipped Eagle Owls. Among the ringing recoveries of juvenile Eagle Owls released from captivity in southeast Norway, at least 52% (n=72) were reported as being due to electrocution (R.S. Larsen, unpubl.). The corresponding figure for juvenile Eagle Owls released in Sweden was 30% (Fremming 1987), for those released in Switzerland at least 27%, and for those released in West-Germany at least 20% (Glutz von Blotzheim and Bauer 1980).

Also for Eagle Owls ringed in the wild electrocution by power lines is an important mortality factor. It has been estimated at 16% in Norway and 20% in Sweden (Fremming 1987), at least 34% in Switzerland (Haller 1978), and at least 30% in both East- and West-Germany (Glutz von Blotzheim and Bauer 1980).

Juvenile Eagle Owls released in southeast Norway thus seemed to be more susceptible to electrocution by power lines than both wild Eagle Owls in Norway as well as both released and wild Eagle Owls elsewhere in Europe. The first difference may be explained by the fact that most ringing of wild Eagle Owls in Norway has taken place in more remote areas than the release of captive birds has. In addition, it spans a period of more than 25 years. The density of power lines in southeast Norway has increased markedly during this period (Fremming 1987).

The radio-equipped Eagle Owls were electrocuted when entering or leaving the poles, which they probably used as hunting perches. This phenomena is well known from North America, where large raptors living in open habitats are particularly vulnerable (Olendorff et al. 1981).

Habitat and prey

Of the two owls that dispersed greater than 10 km and are still alive, one preferred habitats near water. The other did not show any habitat preference. Both owls occurred as often as randomly expected near houses and other buildings, and thus did not show any avoidance of human settlements. This contrasts with what is known for wild Eagle Owls in Norway (Fremming 1987), and may be due to the fact that the radio-equipped birds were raised in captivity, and learned not to fear humans and buildings.

The prey recorded taken by the two owls fit well with what is known from Sweden about prey selection of Eagle Owls in areas with wetlands and farmland mixed with forest (Olsson 1979).

ACKNOWLEDGEMENTS

We thank the Blokkemyr family for providing free accommodation; R.I. Johansen for help with

technical equipment; P. Berglund, K. Engdahl and J. Eriksen for assistance during the radio tracking from ground; and the pilots F. Johnsrud and O. Paulsbo for safe aerial tracking. We also thank B. Danielson for comments on the manuscript, M. Aas for typing the manuscript, and E. Kresse for drawing the figures. The radio-transmitters were financed by the World Wildlife Fund in Norway; and the radio-receiving equipment by grants to G.A. Sonerud from the University of Oslo, the Norwegian Research Council for Science and the Humanities (NAVF), and the Nansen Foundation. The field work was supported by grants to R.S. Larsen from the Nordic Council for Ecology (NCE) and to O.H. Stensrud from the World Wildlife Fund in Norway.

LITERATURE CITED

- Arnkvist, G., H. Danielsson, J. Hjältén, and J. Moen. 1984. Berguven (Bubo bubo L.): Ungfåglars spridning och rörelser under första levnadsåret - en telemetrisk studie. *Gråspetten* 4: 35-41 (In Swedish).
- Bondrup-Nielsen, S. 1978. Vocalizations, nesting and habitat preferences of the Boreal Owl (Aegolius funereus) in North America. M. Sc. thesis, University of Toronto.
- Forbes, J.E., and D.N. Warner. 1974. Behavior of a radio-tagged Saw-whet Owl. *Auk* 91: 783-795.
- Fremming, O.R. 1987. Population decline of Eagle Owl (Bubo Bubo) in East Norway 1920-1980. *Viltrapport* 40: 1-45. (In Norwegian with summary in English).
- Glutz von Blotzheim, U.N., and K.M. Bauer. 1980. *Handbuch der Vögel Mitteleuropas*, Vol. 9. Akademische Verlagsgesellschaft, Wiesbaden.
- Haller, H. 1978. Zur Populationsökologie des Uhus (Bubo bubo) im Hochgebirge: Bestand, Bestandsentwicklung und Lebensraum in den Rätischen Alpen. *Ornithologische Beobachter* 75: 237-265.
- Hayward, G.D., and E.O. Garton. 1984. Roost habitat selection by three small forest owls. *Wilson Bulletin* 96: 690-692.
- Nicholls, T.H., and D.W. Warner. 1972. Barred Owl habitat use as determined by radiotelemetry. *Journal of Wildlife Management* 36: 213-224.
- Nilsson, I.N. 1978. Hunting in flight by Tawny Owls Strix aluco. *Ibis* 120: 528-531.
- Nordiska Ministerrådet. 1984. *Naturgeografisk regionindelning av Norden*. Berlings, Arlöv. (In Danish and Swedish with summaries in English).
- Olendorff, R.R., A.D. Miller, and R.N. Lehman. 1981. Suggested practices for raptor protection on power lines. *Raptor Research Report* No. 4.
- Olsson, V. 1979. Studies on a population of Eagle Owls, Bubo bubo (L.), in southeast Sweden. *Viltrevy* 11: 1-99.
- Smith, D.G., and R. Gilbert. 1984. Eastern Screech-Owl home range and use of suburban habitats in southern Connecticut. *Journal of Field Ornithology* 55: 322-329.
- Sokal, R.R., and F.J. Rohlf. 1969. *Biometry*. Freeman, San Francisco.
- Sonerud, G.A., R. Solheim, and B.V. Jacobsen. 1986. Home-range use and habitat selection during hunting in a male Tengmalm's Owl Aegolius funereus. *Fauna Norvegica, Ser. C, Cinclus* 9: 100-106.
- Winjandts, H. 1984. Ecological energetics of the Long-eared Owl (Asio otus). *Ardea* 72: 1-92.

Geographic Variations in the Diet of Eagle Owls in Western Mediterranean Europe¹

José A. Donázar²

The diet of the eagle owl changes from primarily rabbits in the Typical and Cold Mediterranean regions to a greater variety of smaller mammals in the Humid Mediterranean region. This tendency would lead to extinction in northern Mediterranean mountains.

INTRODUCTION

Since Geroudet (1965) pointed out the lack of information about the food habits of the Eagle Owl (*Bubo bubo*) in the European Mediterranean region, several articles have detailed the prey species of this strigiform, primarily in the Iberian Peninsula and the south of France. Because these food studies include the entire climatic regions of the occidental European Mediterranean, we have been able to use a multivariate analysis to determine taxonomic composition, species diversity, and variability in average prey size with respect to biogeographic changes.

MATERIALS AND METHODS

Following Aschman (1973), three climatic regions within the Occidental Mediterranean have been considered (fig. 1).

1. Typical Mediterranean. In the Iberian Peninsula it comprises the low-elevation regions with marine influence: Portugal, Extremadura, Andalusia, and the Levante coasts. In the south of France and north of Italy it includes only the Riviera area. Within this area, ample information about the diet of the eagle owl has been compiled (Hiraldo et al. 1975a, Vericad et al. 1976, Perez Mellado 1980).

2. Cold Mediterranean. It comprises the high inner regions from the Iberian Peninsula: Mesetas, Ebro Valley. Two works (Hiraldo et al. 1975a, Perez Mellado 1980) detail the diet of the eagle owl in this zone, to which our own data (Donázar 1986) on three localities from the Ebro Valley are added.

1 Paper presented at the symposium, Biology and Conservation of Northern Forest Owls, Feb. 3-7, 1987, Winnipeg, Manitoba, Canada. USDA Forest Service General Technical Report RM-142.

2 José A. Donázar is Dr. of Biology, Museo Nacional de Ciencias Naturales, J. Gutierrez Abascal 2, 28006 Madrid, Spain.

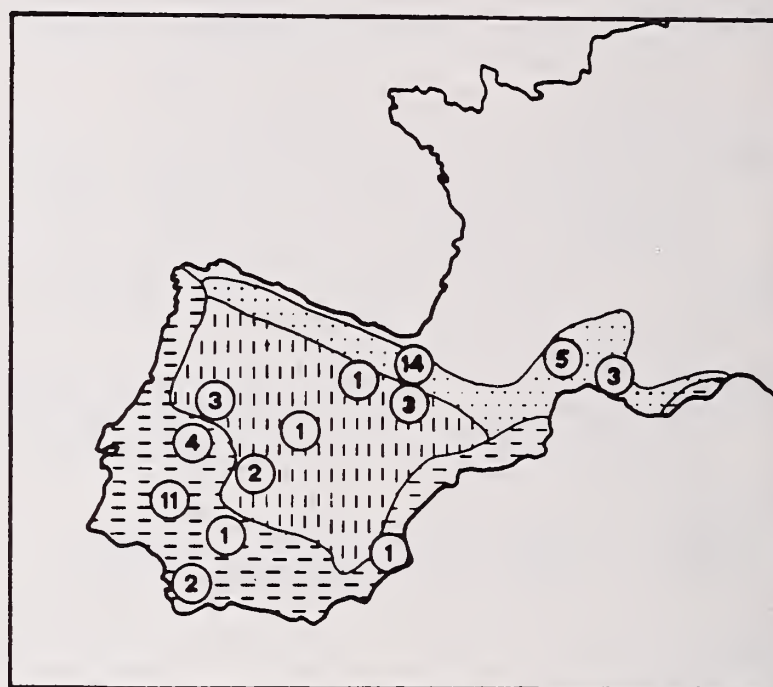

Figure 1.--Division of western Mediterranean Europe on the basis of climatic regions proposed by Aschman (1973). Horizontal dashes: Typical Mediterranean; vertical dashes: Cold Medit.; dotted: Humid Medit. Numbers indicate localities where eagle owl diets were analyzed.

3. Humid Mediterranean. It comprises the areas with Eurosiberian influence in the north edge of the Iberian Peninsula: Cantabric Mountains, Pyrenees, and in France, the Central Massif and the Provence. The diet of the eagle owl has been documented in several publications: Thiollay (1969), Choussy (1971), Schumacher and Lups (1975), Blondel y Badan (1976), Cheylan (1979), Cugnasse (1983), plus our own information about 14 locations from the southwest slope of the Pyrenees (Donázar op. cit.).

With this information, a data matrix has been constructed on the basis of 51 localities, all of which had more than 50 prey. For each locality, the appearance frequency (%) of the following prey

categories was extracted: ERI: Erinaceus europaeus; LAG: Lagomorpha; ARV: Arvicola sapidus; MIC: Microtinae (others); RAT: Rattus; MUR: Muridae (others); GLI: Gliridae; FSF: Falconiforms and Strigiforms; ALE: Alectoris rufa; COL: Columbiforms; COR: Corvidae; TUR: Turdidae; OTA: Other Birds; OTP: Other Vertebrates; INV: Invertebrates. A correspondence factorial analysis allowed us to represent both matrix sets in the same plane, and detect visually associations between location and prey category.

Trophic diversity (H') was calculated by means of the Shannon Index (see Herrera 1974, Jaksic and Marti 1984). The same prey categories defined for the correspondence analysis were considered. The function was calculated with $e^{-\log}$.

The Mean Weight of Prey (MWP) was estimated from bibliographic references (Geroudet 1965, Van de Brink and Barruel 1971, Hiraldo et al. 1975b), which give mean weights for mammals and birds. The rest of the prey weights were calculated from our own data.

RESULTS

The analysis generated three axes that account for 56.73% of the variance (table 1, figs. 2, 3). Axis I accounts for 39.43%, and defines a contraposition between Lagomorpha (in the negative zone) and Rattus and other Muridae (in the positive zone). Looking at the position of localities in the space defined by this axis, a clear bioclimatic gradient can be observed between the most meridional regions (Typical and Cold Mediterranean), where the eagle's diet is based on Lagomorpha (almost exclusively Oryctolagus cuniculus) with some Alectoris rufa, Columbiforms, and Invertebrates, and the Humid Mediterranean regions, where feeding is centered on small mammals.

The second and third axes account for lower proportions of the variance (10.81% and 6.49%), and denote the substitution of alternative prey for Rattus: Microtinae and birds in Axis II, and small Muridae in Axis III.

The localities characterized by a diet based on Rattus are different from a biogeographic point of view (Cold and Humid Mediterranean). Microtinae and birds tend to be the preferred diet in Humid Mediterranean areas of southern France, while the central European influence permits the appearance of social Microtus. On the other hand, the small Muridae (Mus spretus and Apodemus sylvaticus) characterize the diet in the humid regions of northern Spain (Pyrenees) and in a locality of southern France.

Both diet diversity and mean weight of prey show notable interregional variations, but both follow a precise pattern of decreasing MWP and increasing diversity (H') in the south-north direction as the places become colder and wetter

Table 1.--Results of correspondence analyses; contributions of prey categories to formation of each axis. See Methods for significance.

Factor	I	II	III
ERI	0.035	-0.246	0.178
LAG	-0.549	0.259	-0.077
ARV	0.092	-0.056	-0.002
MIC	0.095	-0.420	0.039
RAT	0.485	0.363	0.691
MUR	0.610	0.185	-0.619
GLI	0.031	0.048	-0.008
FSF	0.040	-0.177	-0.044
ALE	-0.129	0.022	-0.049
COL	-0.099	-0.067	-0.093
COR	0.081	-0.455	0.122
TUR	0.094	0.143	-0.199
OTA	0.060	-0.513	0.105
OTP	0.023	-0.032	-0.065
INV	-0.152	0.071	0.131
Variance (%)	39.43	10.81	6.49
Cum. Var. (%)	39.43	50.24	56.73

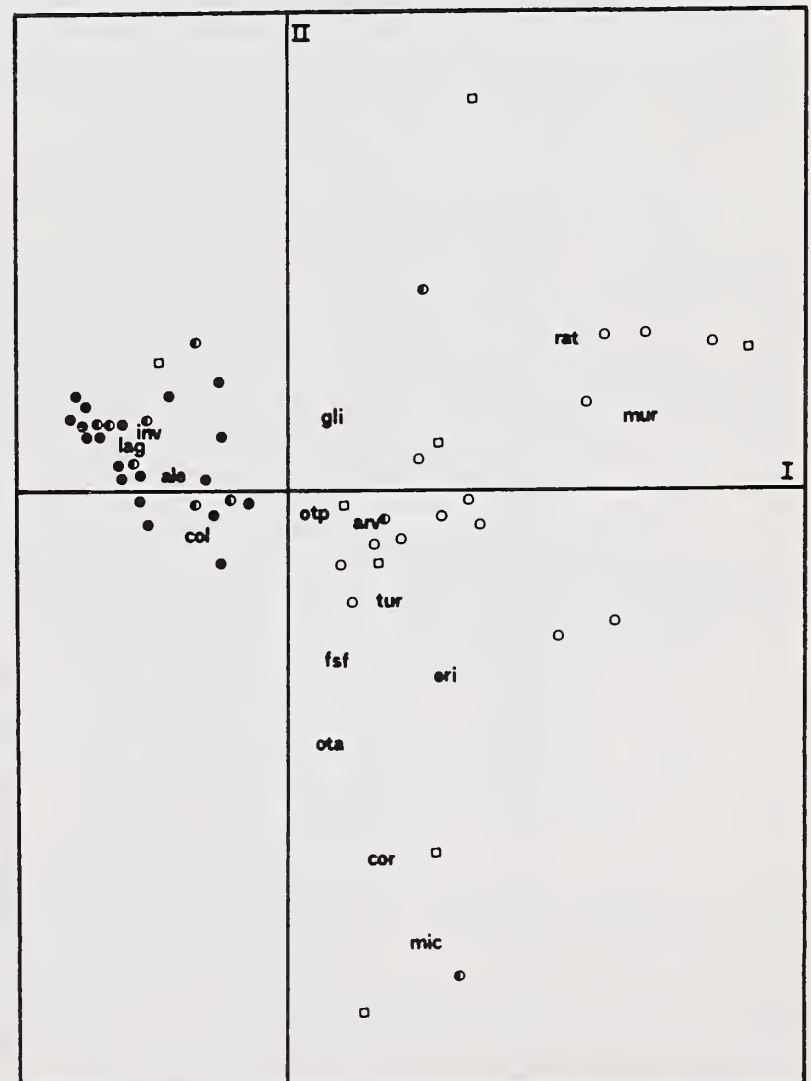

Figure 2.--Ordination of localities and prey categories on axes I and II. ●: Iberia, Typical Mediterranean; ◐: Iberia, Cold Medit.; ○: Iberia, Humid Medit.; □: France, Humid Medit. region. See Methods for significance.

(table 2). The statistical significance of the interregional differences has been calculated by means of Student t-tests. The results (table 3) show that the Typical and Cold Mediterranean regions tend to be homogeneous between themselves, as do the two Humid Mediterranean subregions (Iberian and French). With respect to H', however, southern France tends to resemble the Cold and Typical Mediterranean regions, due perhaps to the proximity of certain sample areas (Provence) to the Riviera.

DISCUSSION

The close spatial association among localities in the Typical and Cold Mediterranean regions seems to be a logical result of the extraordinary abundance of rabbits in these ecosystems (Soriguer 1981), and consequently, their high food value for the eagle owl (Hiraldo et al. 1975a). This would lead to the trophic specialization of the owl, and thus the reduced diversity index and high average size of prey.

In Humid Mediterranean regions, however, the rabbit occurs in low densities with a fragmented spatial distribution (Cheylan 1979, Ceballos in prep.). This seems to induce the owl to complete its diet with prey of less food value: rats and

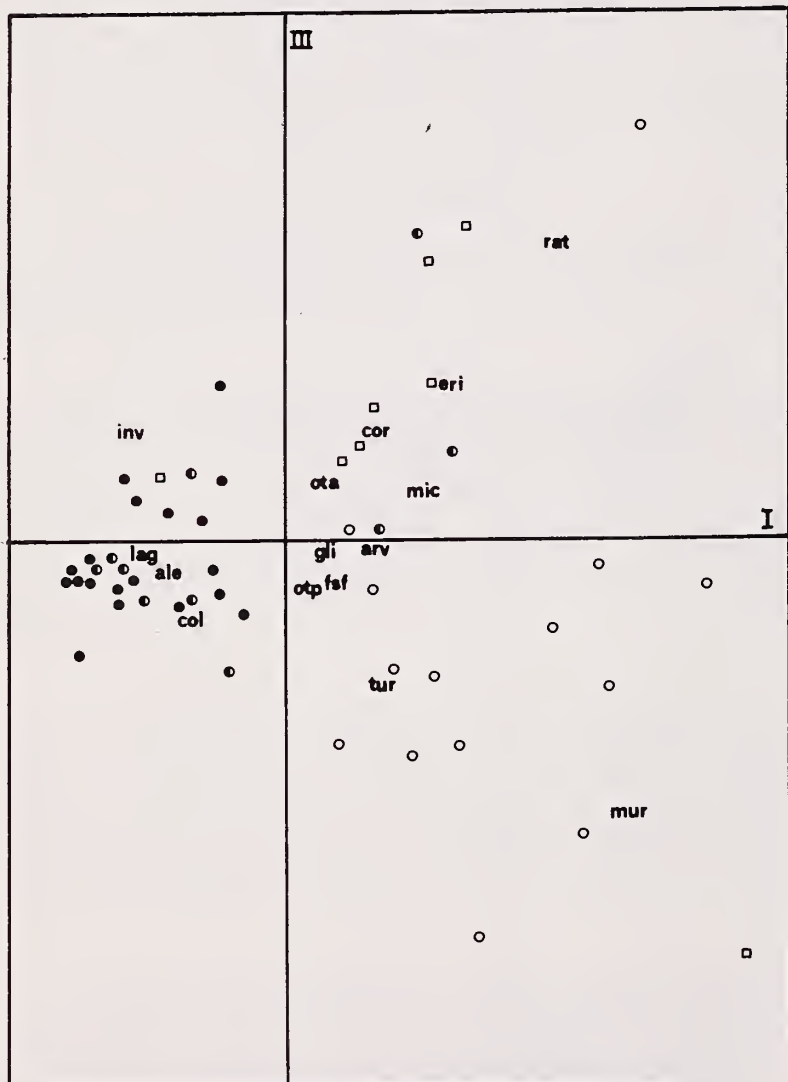

Figure 3.--Ordination of localities and prey categories on axes I and III. Symbols same as in fig. 2.

Table 2.--Values of trophic diversity (H') and mean weight of prey (MWP) in each region considered.

Region	H'	MWP	n
Iberia typical	1.209 (492.3)	889.2 (200.1)	19
Iberia cold	1.223 (433.9)	726.4 (233.4)	10
Iberia humid	1.842 (0.368)	395.9 (128.9)	14
France humid	1.715 (731.0)	515.5 (238.9)	8

Table 3.--Values of Student t-tests in comparisons among climatic regions with respect to H' and MWP. ns: not significant; x: p < 0.05; xx: p < 0.01; xxx: p < 0.001.

Iberia cold	Iberia humid	France humid	H'
0.756 n.s.	4.045 xxx	2.108 x	Iberia typical
	3.772 xx	1.779 n.s.	Iberia cold
		0.547 n.s.	Iberia humid

Iberia cold	Iberia humid	France humid	MWP
1.969 n.s.	8.060 xxx	4.193 xxx	Iberia typical
	4.454 xxx	2.827 x	Iberia cold
		1.538 n.s.	Iberia humid

small Muridae. The main substitution prey, the brown rat, has a biomass theoretically very appropriate to the strigiform needs (Donazar 1986) since it fulfills the dietary requirements of the owl (see Glutz von Blotzheim and Bauer 1980). Nevertheless, its presence in the diet is limited to a few localities with no biogeographic connection. This can be due to the fact that the rodent has an irregular spatial distribution, being mostly linked to human developments (Perez Mellado 1980, Real et al. 1985, Donazar 1986).

That would force the eagle owl to feed on smaller animals, primarily Microtinae and small Muridae.

One of these species, Mus spretus, can reach 40% of the owl's captures in some Pyrenean localities (Donázar 1986). This contradicts opinions of other authors (Jaksic and Marti 1984, Orsini 1985), who consider improbable the capture of this small mammal, very common in the western European Mediterranean region, because of its low body weight (not more than 20 g.). Our data tend to indicate that Mus, like other small mammals, is preyed upon by eagle owls on the basis of availability of prey of greater food value (Pyke 1977), as is the case with other birds of prey (Davies 1977, Goss-Custard 1977, Krebs et al. 1977).

The substitution of small mammals for rabbits leads to an increase in prey diversity and decrease in mean weight of prey toward the Humid Mediterranean region. This tendency is a common phenomenon for large predators on the Iberian Peninsula: Aquila chrysaetos, A. adalberti, Hieraaetus fasciatus, Lynx pardina (Caldron et al. 1980, Delibes 1980, Alamany et al. 1984, Garzon et al. 1984). The eagle owl thus differs from other European strigiforms, which tend to fluctuate rapidly in Typical Mediterranean regions when rodents are scarce (Herrera 1974, Delibes 1975, Manéz 1983).

This progressive substitution of smaller prey can lead to a loss in hunting efficiency, which can cause an energy deficit if the eagle's larger prey are scarce and the energy costs of searching for and capturing smaller prey exceed their food value (see Valverde 1967, Schoener 1971). This opinion is substantiated by the fact the eagle owl was partially extinct in certain Humid Mediterranean areas (Pyrenees of Navarre, French Central Massif) due to the epizootic disease, mixomatosis, which caused the virtual disappearance of the rabbit (Choussy 1971, Purroy 1974). The subsequent recovery of the rabbit population was followed by expansion of the eagle owl range to recover part of the lost area (Bergier y Badan 1979, Cheylan 1979). This seems to indicate that, in the absence of large prey, the eagle owl is unable to survive on a diet based exclusively on small mammals. Thus the mountains of northern Mediterranean regions have a notable parallelism with the nordic ecosystems (taiga) where, in some areas, the eagle owl similarly consumes a large proportion of small rodents and has suffered population losses conditioned by the disappearance of some larger prey species (Olsson 1979, Mysterud and Dunker 1983).

ACKNOWLEDGEMENTS

The main part of this work was supported by the Gobierno Vasco through an FPI grant. Dr. F. Hiraldo read and made many constructive comments upon a draft of this paper and on an earlier analysis of data, presented in thesis form. I also thank T. Lopez Unzu for the translation into English.

LITERATURE CITED

- Alamany, O., A. De Juan, X. Parellada and J. Real. 1984. Status de l'aliga cuabarrada (Hieraaëtus fasciatus) a Catalunya. *Rapinyaires Mediterranis* 2: 98-108.
- Aschman, H. 1973. Distribution and peculiarity of mediterranean ecosystems p. 11-19. In Di Castri, F. and H.A. Mooney (eds.) *Mediterranean Type Ecosystems*.
- Bergier, P and O. Badan. 1979. Complements sur la reproduction du Grand-Duc (Bubo bubo) en Provence. *Alauda* 47: 271-275.
- Blondel, J. and O. Badan. 1976. La biologie du Hibou Grand Duc en Provence. *Nos Oiseaux* 33: 189-219.
- Calderón, J., M. Delibes and F. Amores. 1980. E Ecología y status del águila real (Aquila chrysaetos L.) en España. I Reunión Iberoamer. Zool. Vert. La Rábida 1977: 705-719.
- Cheylan, G. 1979. Recherches sur l'organisation du peuplement de vertébrés d'une montagne méditerranéenne. These Doctorale (unpubl.). Université Pierre et Marie Curie. Paris.
- Choussy, D. 1971. Etude d'une population de Grands-Ducs Bubo bubo dans le Massif Central. *Nos Oiseaux* 31: 37-56.
- Cugnasse, J.M. 1983. Contribution a l'etude du Hibou Grand-Duc, Bubo bubo, dans le sud du Massif Central. *Nos Oiseaux* 37: 117-128.
- Davies, N.B. 1977. Prey selection and the search strategy of the spotted flycatcher (Muscicapa striata): a field study on optimal foraging. *Anim. Behav.* 25: 1016-1033.
- Delibes, M. 1975. Some characteristics features of predation in Mediterranean Ecosystems. *Proc. XI Int. Cong. Game. Biol.* Lisboa.
- Delibes, M. 1980. El lince ibérico. Ecología y comportamiento alimenticios en el Coto Doñana, Huelva. Doñana, *Acta Vertebrata* 7-3.
- Donázar, J.A. 1986. El búho real (Bubo bubo L.) en Navarra: Población, análisis de la distribución, ecología trófica, reproducción y crecimiento. Tesis Doctoral (unpubl.). Universidad de Navarra.
- Garzón, J., L.M. González, J.L. González and F. Hiraldo. 1984. Situación actual y problemática del águila imperial ibérica (Aquila adalberti BREMH, 1861) en España. *Rapinyaires Mediterranis* 2: 60-69.
- Geroudet, P. 1965. La vie des oiseaux. Delachaux et Niestlé. Neuchâtel.
- Glutz von Blotzheim, U.N. and K. Bauer. 1980. *Handbuch der Vögel Mitteleuropas*. Vol. 9. Columbiformes-Piciformes. Akademische Verlagsgesellschaft., Weisbaden.
- Goss-Custard, J.D. 1977. Optimal foraging and the size selection of worms by redshank, Tringa totanus, in the field. *Anim. Behav.* 25: 10-29.
- Herrera, C.M. 1974. Trophic diversity of the Barn Owl Tyto alba in Continental Western Europe. *Ornis Scand.* 7: 29-41.
- Hiraldo, F., J. Andrada and F.F. Parreño. 1975 a. Diet of Eagle Owl Bubo bubo in Mediterranean Spain. Doñana, *Acta Vertebrata* 2: 161-177.
- Hiraldo, F., F. Fernandez and F. Amores. 1975 b. Diet of Montagus' Harrier (Circus pygargus) in southwestern Spain. Doñana, *Acta Vertebrata* 2: 25-55.

- Hiraldo, F., F.F. Parreño, V. Andrada and F. Amores. 1976. Variations in the food habits of the European Eagle Owl (Bubo bubo). Doñana, Acta Vertebrata 3: 137-156.
- Jaksic, F.M. and C.D. Marti. 1984. Comparative food habits of Bubo owls in Mediterranean-type ecosystems. Condor 86: 288-296.
- Krebs, J.R., J.T. Erichsen, M.I. Webber and E.L. Charnov. 1977. Optimal prey selection in the great tit (Parus major). Anim. Behav. 25: 30-38.
- Mañez, M. 1983. Variaciones geográficas y estacionales en la dieta del mochuelo común (Athene noctua) en España. XV Congr. Int. Fauna Cinegética y Silvestre, Trujillo 1981: 617-634.
- Mysterud, I. and H. Dunker. 1983. Food and Nesting Ecology of the Eagle Owl, Bubo bubo (L.) in Four Neighbouring Territories in Southern Norway. Viltrevy 12: 71-113.
- Olsson, V. 1979. Studies on a population of Eagle Owls. Viltrevy 11: 1-99
- Orsini, P. 1985. Le régime alimentaire du hibou grand duc Bubo bubo en Provence. Alauda 53: 11-28.
- Perez Mellado, V. 1980. Alimentación del búho real (Bubo bubo) en España Central. Ardeola 25: 93-112.
- Purroy, F.J. 1974. Fauna navarra en peligro de extinción. Ediciones y Libros. Pamplona.
- Pyke, G.H., H.R. Pulliam and E.L. Charnov. 1977. Optimal foraging: A selective review of theory and tests. Q. Rev. Biol. 52: 137-154
- Real, J., A. Galobart and J. Fernandez. 1985. Estudi preliminar d'una població de duc Bubo bubo al Valles i Bages. In El Medi Natural del Valles. I Coloqui de Naturalistes Vallesans. Annals del C.E.E.M. nº 1 Sabadell: 175-187.
- Schoener, T.W. 1971. Theory of feeding strategies. Annu. Rev. Ecol. Syst. 2: 369-404.
- Schumacher, E. and P. Lüps. 1975. Angaben zur Ernährung des Uhus Bubo bubo (L. 1758) in der Provence (Südfrankreich). Jahrb. der Naturhist. Mus. Bern. 5: 217-222.
- Soriguer, R. 1981. Biología y dinámica de una población de conejos (Oryctolagus cuniculus, L.) en Andalucía Occidental. Doñana, Acta Vertebrata 8-3.
- Thiollay, J.M. 1969. Essai sur les rapaces du midi de la France. Distribution-ecologie. Hibou Grand-Duc Bubo bubo bubo L.. Alauda 37: 15-27.
- Valverde, J.A. 1967. Estructura de una comunidad mediterránea de vertebrados terrestres. 1ª monografía de la Estación Biológica de Doñana. C.S.I.C. Madrid.
- Van de Brink, F.H. and P. Barruel. 1971. Guía de campo de los mamíferos salvajes de Europa Occidental. Ediciones Omega, Barcelona.
- Vericad, J.R., A. Escarré and E. Rodriguez. 1976. Datos sobre la dieta de Tyto alba y Bubo bubo en Alicante (SE de Iberia). Mediterránea 1: 47-59.

Addled Eggs in Great Horned Owl Nests in Saskatchewan¹

C. Stuart Houston,² Roy D. Crawford,³ and Donald S. Houston⁴

Abstract.--In visits to 1716 nests of the Great Horned Owl, addled eggs were present in from 1.2 to 9.3% of successful nests, and in another 11 nests without young. Addled eggs (4 of 5 opened contained identifiable dead embryos) were most common in years of poor reproductive success.

INTRODUCTION

Comprehensive studies of reproductive failure in domestic fowl, a matter of great economic importance, have been carried out for over 100 years. A landmark paper by Riddle (1930) studied doves, pigeons and domestic fowl and reported that the embryos of all showed "two distinct periods of high mortality ... very early in development and ... very near the end of incubation." After a detailed list of possible causes of embryo death, Riddle concluded that thick shells, "the very device ... utilized by eggs to prevent water-loss--and avoid death in the final period--may too greatly affect respiratory exchange and thus cause death in the early period." Insko and Martin (1935) found that for White Leghorn chick embryos, the peaks of mortality fell on the 2nd and 19th days of a 21-day incubation and for Bronze Turkey embryos on the 4th and 25th days of a 28-day incubation.

Ricklefs (1969) reported that the incidence of unhatched eggs averaged 8% in six species of passerine birds. Little has been written about this problem in North American raptors. The incidence of unhatched eggs of the Red-tailed Hawk, Buteo jamaicensis, Northern Goshawk, Accipiter gentilis, Prairie Falcon, Falco mexicanus, and Screech Owl, Asio otus, has been reported as 4%, 10%, 11%, and 18%, respectively (Luttitch et al 1971; McGowan 1975; Ogden & Hornocker 1977; Klaas and Swineford 1976).

We studied hatching failure in the Great Horned Owl, Bubo virginianus, as measured by the frequency of addled eggs encountered during visits to 1727 active nests in Saskatchewan. Hatching failure (Ricklefs 1969) can result from:

1. Infertile eggs
2. Death of initially viable eggs (usually early in incubation)
3. Death of a fully-formed chick at or during hatching.

[Nest failure with egg loss, beyond Ricklefs definition of hatching failure, can also result from death of the adult owls, desertion (Southern 1970) or predation (Lundberg 1985), but in owls it should rarely be due to parasitic infestation, nest site competition or severe storms, and never to brood parasitism.]

We follow standard dictionaries in equating addled and rotten as synonymous. We do not have enough data to be as specific as Campbell and Lack (1985) who, without citing any authority for their decision, define an addled egg as one "in which the developing embryo has died, as opposed to an infertile egg in which no development has taken place." Although we presume that an infertile egg would "dry down" rapidly during incubation and might break before fertile eggs had hatched and before bacterial growth could proceed to the "slosh" stage, we nevertheless have only preliminary evidence to suggest that most or all addled eggs represent embryo death.

METHODS

The senior author and his many volunteer assistants have recorded presence or absence of unhatched eggs during visits to raptor nests since 1966. Eggs in nests with tiny young were not disturbed, since hatching is staggered in owls and such eggs may have been viable. If the smallest nestling was one week or more old, the egg was shaken. Eggs that had an audible "slosh" from air and fluid content (indicating cell death, autolytic breakdown of membranes, mixing of liquefied yolk and white, and secondary bacterial overgrowth), were classed as addled and taken from the nest.

¹Paper presented at the symposium, Biology and Conservation of Northern Forest Owls, Feb. 3-7, 1987, Winnipeg, Manitoba. USDA Forest Service General Technical Report RM-142.

²Stuart Houston is Professor of Medical Imaging, University of Saskatchewan, Saskatoon, Sask. ³Roy Crawford is Professor of Animal and Poultry Science, University of Saskatchewan, Saskatoon, Sask. ⁴Donald Houston is resident in medicine, Health Sciences Centre, University of Manitoba, Winnipeg, Man.

TABLE 1 - YEARLY VARIATION IN ADDLED EGGS IN GREAT HORNED OWL

Year	Nests	Yg	Ratio	Percent	#N	0Y	0Y	0Y	1Y	1Y	1Y	2Y	2Y	3Y
						with	1e	2e	3e	1e	2e	1e	2e	1e
						ad								
						e								
1966	51	116	2.27	3.92%	2					2				
1967	110	255	2.32	3.64%	4		1		0	1		2		
1968	163	401	2.46	3.07%	5				2			2		1
1969	85	224	2.64	1.18%	1							1		
1970	113	282	2.50	1.77%	2				1			1		
1971	62	132	2.13	3.23%	2	1			1					
1972	76	167	2.20	6.58%	5		1		2			2		
1973	27	49	1.81	3.70%	1				1					
1974	38	65	1.71	5.26%	2				1			1		
1975	69	145	2.10	7.25%	5	1	2	1	1					
1976	54	107	1.98	9.26%	5		1		2			2		
1977	67	151	2.25	2.99%	2							2		
1978	81	191	2.36	1.23%	1									1
1979	84	211	2.51	3.57%	3				1			2		
1980	65	116	1.78	4.62%	3		1		2					
1981	148	374	2.53	4.73%	7				3			1	1	2
1982	80	157	1.96	3.75%	3				1	1		1		
1983	101	208	2.06	1.98%	2				2					
1984	103	197	1.91	3.88%	4	1			3					
1985	55	106	1.93	7.27%	4	1			2			1		
1986	84	207	2.46	5.95%	5				1			3	0	1
TOTAL	1716	3861	2.25	3.96%	68	4	6	1	28	2	0	21	1	5

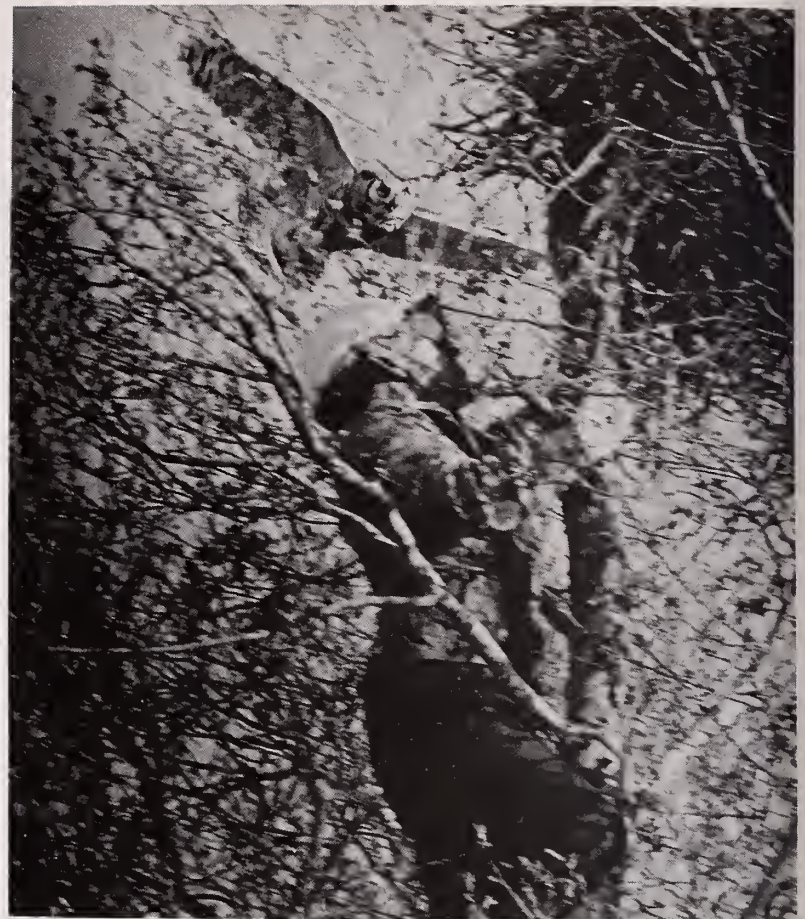

Great Horned Owl attacking Houston
(Photo, Hans S. Dommasch)

RESULTS

Until 1985, all addled eggs were frozen and sent to the Canadian Wildlife Service (CWS) in Ottawa at the end of the season. Few of these eggs have been analysed chemically, but they have been kept frozen in a reference collection, available for possible retrospective study of pesticide content and egg shell thickness, should data from that period or location come to be of interest.

In 1986 we attempted for the first time to determine whether an addled egg indicated embryo death or infertility. Only in this one year were eggs candled, then broken and examined in Saskatoon. (Frozen eggs in the CWS repository are unsuitable for candling).

The number of nests found each year varied greatly (27-163), in spite of approximately constant effort by a group of farmer friends with a special knack for finding owl nests. At the low point in the cycle of the Snowshoe Hare, *Lepus americanus*, most owls moved away, and of those remaining, less than half made any attempt to nest (Houston 1975b).

Because of the unusually wide variability in breeding activity and success in this species, it is inadequate merely to plot the number of addled eggs encountered each year. Hence the number of addled eggs was compared to the number of successful breeding pairs and to the total number of eggs produced each year.

Between 1966 and 1986, inclusive, the senior author visited 1727 Great Horned Owl nests with eggs or young. Of these, 1716 successful nests produced one or more young to banding age; the other 11 occupied nests contained only addled eggs. Altogether there were 79 addled eggs in 68 nests, involving 4% of all nests and 2% of all eggs. The frequency of nests with addled eggs ranged from a low of 1.2% of nests in 1969, the year with the highest number of young fledged per successful nest, to a high of 9.3% in 1976, a year of below-average breeding success (Table 1).

Of the eleven nests which had addled eggs only, without young, four had one addled egg, six had two, and one had three. Four of the 11 nests with addled eggs but no young were found in 1975, a year of low owl production. Of 57 nests with addled eggs and live young, the most frequent combination was one addled egg and one live owlet (28 nests), followed by one addled egg with two live young (21 nests). Three nests with young owls contained two addled eggs each (Table 1).

Addled eggs feel cool to the touch, indicating lack of recent incubation, and are well preserved during cool weather in April and May. Eggs of ducks, coots and upland game, brought to the nest in the oviduct of prey species, are also well preserved in owl nests (Houston 1975a). In contrast, hawk eggs found in midsummer are often

exposed to ambient temperatures as high as 40° C. Excessive decomposition and bacterial overgrowth may make it impossible to detect embryonic remnants (Houston, Fox, Crawford, Oliphant, mss.)

In 1986, the only year in which owl eggs were sacrificed for direct examination, three contained a small embryo, indicating failure early in incubation. One contained a fully formed dead embryo with pinfeathers and a prominent egg tooth. One egg contained no recognizable embryonic material.

The years with the most nests and most eggs per nest were the years with the lowest proportion of addled eggs, while years of fewer nests and fewer eggs per nest had a higher proportion of addled eggs. Regression analysis reveals a significant negative correlation ($p < 0.01$) between the percentage of addled eggs and the number of young per nest (Figure 1). This correlation is only moderately strong, with an r value of 0.51. In a year of below-average owl success (Houston 1971), the increased percentage of addled eggs is only one of the measures of poor reproductive performance.

DISCUSSION

In spite of early nesting under extreme climatic conditions, and cyclic variability in numbers of its main prey species, the Great Horned Owl has an unusually low incidence of addled eggs. However, there is a significant inverse relation between the annual proportion of addled eggs and the average number of young produced per successful nest that year -- which in turn is related to food availability. This is a natural phenomenon; given a herbivorous prey species in late winter, there is little potential for accumulation of biocides.

Brief interruptions of incubation, obligatory even in the coldest weather, cause no harm because "the avian blastoderm is capable of withstanding a relatively severe degree of cold" (Romanoff). We have not observed any obvious correlation with inclement weather, but we have not done regression calculations against weather variables such as temperature and snow depth. In fact, we have observed a Great Horned Owl incubating two eggs successfully through temperatures as low as -34 C. (Houston 1965). We hypothesize that a normal degree of cold might have adverse consequences only in years when the male brings insufficient food to the incubating female who is thereby forced to leave the nest for longer than normal periods to obtain food for herself.

Results from random visits to owl nests are not directly comparable to results of poultry science research. In the laboratory, a failed egg is studied before decomposition sets in. In the field, the addled egg that "sloshes" teems with bacteria; decomposition may have been under way for many weeks. Nevertheless, our small sample of five rotten eggs in 1986 suggests that such eggs are more commonly the result of embryo death than infertility. We encountered three instances of

early and one of late embryo death, roughly consistent with the classic studies in domestic fowl.

It is our working hypothesis, supported by our small sample in 1986, that addled Great Horned Owl eggs represent embryonic death with secondary infection, not primary infection or infertility. When death of the embryo occurs, there is immediate failure of the normal bacteriostatic and immunologic mechanisms of the live organism; diversified microorganisms already residing on or even in the eggshell soon proliferate in the excellent culture medium. In poultry, fertile and infertile eggs are contaminated about equally (Romanoff and Romanoff 1949).

Other Long-term Studies

Our inverse relationship between addled eggs and food availability is consistent with the only other long-term studies of variation in the incidence of addled raptor eggs, from Europe. In the Buzzard, Buteo buteo, addled eggs constituted 5% of all incubated eggs in good food years and 15% in poor ones (Mebs 1964). In the Tawny Owl, Strix aluco, the loss of 115 of 279 eggs was ascribed to "desertion and chilling" and was most frequent when the female left her nest because food supplies were scarce (Southern 1970). Our results agree with the prediction of Lundberg (1985) that, given a low daily risk of predation, a larger clutch size should accompany increased food availability. On the other hand, our results are contrary to Lundberg's other prediction, on evolutionary grounds, that low predation and increased clutch size might be accompanied by a higher rate of egg failure.

Usefulness of this information

Knowledge of the average and range of extremes of frequency of rotten eggs should help to understand relationships between reproductive success and food availability. In some species it might also prove useful in early detection of biocide effects, since some biocides increase the risk of reproductive failure (Newton and Bogan 1974). Differentiation between chemicals causing infertility and those causing early or late embryo death might be important.

Our retrospective data, collected incidental to a long-term banding effort, point to the need for more detailed studies, including histologic examination of dead embryos. We encourage others to take an interest in this neglected area.

ACKNOWLEDGEMENTS

Glen A. Fox, J. Bernard Gollop, Mary I. Houston, Lynn O. Oliphant and Josef A. Schmutz offered constructive criticism of an initial draft of this manuscript.

LITERATURE CITED

- Campbell, B., and Lack, E. 1985. A dictionary of Birds. p.3. Buteo Books, Vermillion, South Dakota.
- Houston, C.S. 1965. Observation and salvage of Great Horned Owl nest. Blue Jay 23:164-165.
- Houston, C.S. 1975a. Eggs of other species in Great Horned Owl nests. Auk 92:377-378.
- Houston, C.S. 1975b. Reproductive performance of Great Horned Owls in Saskatchewan. Bird Banding 46:302-304.
- Insko, W.M. Jr., and J.H. Martin. 1935. Mortality of the Turkey embryo. Poultry Science 14:361-364.
- Klaas, E.E., and D.M. Swineford. 1976. Chemical residue content and hatchability of Screech owl eggs. Wilson Bulletin 88:421-426.
- Lundberg, S. 1985. The importance of egg hatchability and nest predation in clutch size evolution in altricial birds. Oikos 45:110-117
- Luttitch, S.N., L.B. Keith, and J.D. Stephenson. 1971. Population dynamics of the Red-tailed Hawk (Buteo jamaicensis) at Rochester, Alberta. Auk 88:73-87.
- McGowan, J.D. 1975. Distribution, density and productivity of Goshawks in interior Alaska. Report of Alaska Dept. of Fish & Game.
- Mebs, T. 1964. Zur biologie und populationsdynamik des Mäusebussards (Buteo buteo). Journal für Ornithologie 105:247-306.
- Newton, I., and J. Bogan. 1974. Organochlorine residues, eggshell thinning and hatching success in British sparrowhawks. Nature 249:582-583.
- Ogden, V.T., and M.B. Hornocker. 1977. Nesting density and success of Prairie Falcons in southwestern Idaho. Journal of Wildlife Management 41:1-11.
- Ricklefs, R.E. 1969. An analysis of nesting mortality in birds. Smithsonian Contributions to Zoology #9.
- Riddle, O. 1930. Studies on the physiology of reproduction in birds. 27: the age distribution of mortality in bird embryos and its probable significance. American Journal of Physiology 94:535-547.
- Romanoff, A.L. 1960. The avian embryo: structural and functional development. Macmillan, New York.
- Romanoff, A.L. & A.J. Romanoff. 1949. The avian egg. John Wiley & Sons, New York.
- Southern, H.N. 1970. The natural control of a population of Tawny Owls (Strix aluco). Journal of Zoology (London) 162:197-285.

Some Features of Long-Eared Owl Ecology and Behavior: Mechanisms Maintaining Territoriality¹

Vladimir I. Voronetsky²

Abstract.--Territorial behavior of 48 pairs of Long-eared Owls was studied for 14 years in an area 60 km west of Moscow. All members of an owl family--male, female and young--play a role in territorial defense. The complex behavior and vocalizations exhibited by parents and their offspring changes during the breeding season. This unusual territorial defense system evidently ensures greater hunting and breeding success in the Long-eared Owl, which has specialized food habits and is highly nocturnal.

The territorial behavior of 48 Long-eared Owl (*Asio otus*) families was studied for 14 seasons in the Moscow area (60 km west of Moscow). In the biotope inhabited by the families, tape recordings or imitations of other owls' voices were periodically played or given and adult or young owls were exhibited.

Territoriality in this species is ensured by complicated behavioral mechanisms supported by all members of the family. The male, the female and the young at different stages of the breeding period manifest various territorial-defensive reactions using polyfunctional acoustic signals or series of signals. The behavioral patterns maintaining territoriality in general can be described as follows:

1. Territorial males in the early breeding stage are actively vocalizing. Their low-frequency acoustic signals (Fig. 1), strengthened by demonstrative flights and wing-clapping, are well known. The effect of this behavior is later enhanced by the female who exchanges calls with the male and moves across the habitat clapping her wings in flight like the male. Thus, territorial behavior during the display period comprises a set of acoustic signals and demonstrations by male and female. The wide variety of signals used by the Long-eared Owl ensure the necessary reliability of this form of signal in the unsteady

spring weather conditions when the environment is saturated by low-frequency noises.

2. With the beginning of incubation the intensity of demonstrations on the territory sharply decreases. One to two weeks after the beginning of egg-laying the males as a rule have ceased displaying and do not respond to other

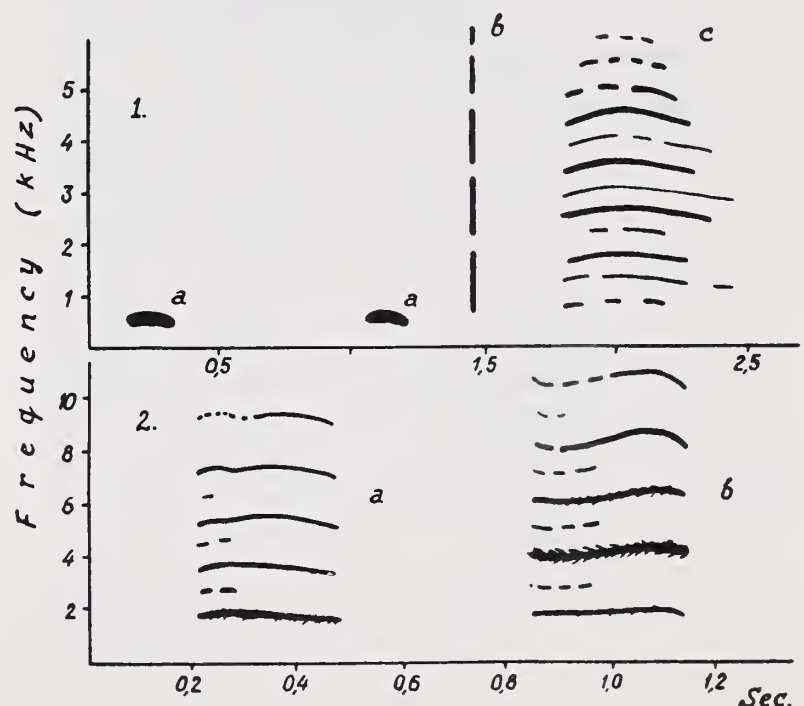

Figure 1.--Sonograms of display acoustic signals: male hooting (a), wing-clapping (b) and female call (c).

Figure 2.--Sonograms of young owls' polyfunctional acoustic signals in normal condition (a) and aggression (b). Fundamental frequency is shifted to the higher range of acoustic spectrum.

¹Paper presented at the symposium, Biology and Conservation of Northern Forest Owls, Feb. 3-7, 1987, Winnipeg, Manitoba. USDA Forest Service General Technical Report RM-142.

²Vladimir Voronetsky is on the Faculty of Biology, Department of Vertebrate Zoology, Moscow State University, Moscow, USSR.

males' voices. At this time they defend only one part of their territory--the hunting area. Incubating females become more and more indifferent to male display signals, but increasingly aggressive to voices of other females (Fig. 2) and strange owlets. In this situation, females show a wide range of reactions--from irritated cries upon the nest to direct aggression and chasing accompanied by a large repertoire of aggressive signals. This pattern of female behavior is maintained during the whole period of feeding of the young by the mother, but it declines as soon as the fledglings become fully capable of flying.

3. Young owls, along with the development of the acoustic signals, show behavioral reactions from approximately 2 weeks of age that function in maintenance of the territory. The nestling feeding call acquires polyfunctional significance and can serve as a reliable territorial marker. Probably it is the reason why such signals have unexplainably high intensity. The nestlings react to the appearance of a strange brood near the nest by increasing the intensity of their calls and producing them more often, while the fundamental frequency of the signals is shifted to the higher range of the acoustic spectrum (Fig. 3). In the same situation the fledglings show similar vocal alterations. In addition, they actively seek the source of sounds and try to approach it. The aggression of the young is usually supported by the female. Their collective attacks on intruders at the territorial border continue until the strange brood leaves the host territory.

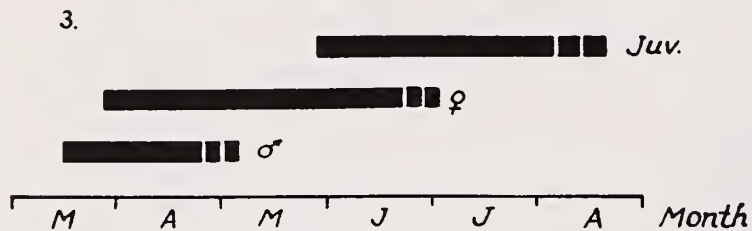
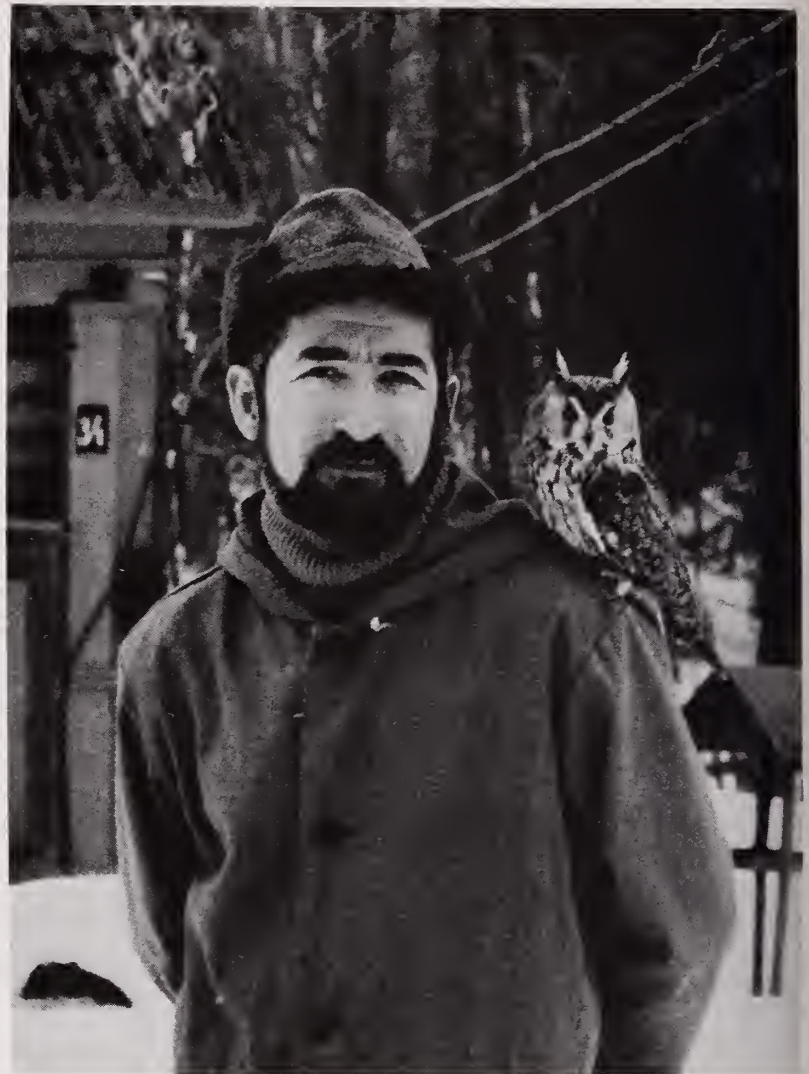

Figure 3.--Vocalization time periods of different members of the brood during the breeding season.

4. Towards the end of the nesting period, the intensity of the female and fledgling reactions to intruders steadily decreases. It enables some young owls that have not yet been fed by their parents to approach the intruding family groups



Voronetsky and a long-eared friend.

and to beg food from the strange parents. It is especially important during the period when independent hunting by the young is difficult because of prolonged rains or strong winds.

Thus, the complicated system of territorial defense in the Long-eared Owl, while being extremely individually variable, is ensured by the optimal distribution of functional roles between the members of the family during the whole breeding period. Such a system evidently provides greater hunting and breeding success in this species which is specialized for a nocturnal life strategy and practically strict myophagia.

Food and Food Ecology of the Long-Eared Owl in an Agricultural Area¹

Josef Kren²

Artificial perches installed in an intensively exploited agricultural area were heavily used by Long-eared Owls. Primary prey species, determined by analysis of pellets beneath the perches, were Common Voles and other species regarded as major agricultural pests. The nature of the prey indicates a narrow food spectrum related to the monoculture.

The present paper is a partial result of a food ecology study of two of our most common owls, the Long-eared Owl and the Tawny Owl, in an intensively used agricultural landscape. Even though the food ecology of the Long-eared Owl has been dealt with by many writers, both in Czechoslovakia and in other European countries, these problems have been very topical in connection with the possibility of utilizing birds of prey in the integrated protection of agricultural monocultures.

In Czechoslovakia the food of the Long-eared Owl was studied in detail--on the basis of pellets by Farský (1928), Fojk (1956), Zelený (1961), Boháč and Michálková (1970) and Bejček (1980). The material processed by them came from different environments.

I have analysed 682 pellets collected at four sites in South Moravia (Czechoslovakia). All sites were located in an intensively exploited agricultural area and were similar in all respects. An important element of this landscape were freely scattered groups of trees and shrubs of different ages which, however, did not constitute continuous stands. The sites near the village of Kostelany (denoted as "C") are situated in a close neighbourhood of a flood-plain forest. The remaining sites are denoted: ("A") near the village of Kolní Némci, ("B") near the village of Hluk, and ("D") near the village of Traplice.

Pellets were collected under T-shaped perches installed in alfalfa fields to support the predation activity of birds of prey for the purpose of controlling small rodents. In autumn of 1982 and 1983 temperatures were normal.

In 682 analyzed pellets skeletal remnants of 1368 animals were found belonging to the classes Aves and Mammalia. Mammals were represented by five species, the number of skeletal remains belonging to 1357 individuals, which constitute the main part of the prey. The most common species was the Common Vole (*Microtus arvalis*) whose percentage representation for the 2 years was 90.3%. The second most numerous representatives were Mouse species (*Apodemus* sp.). Their total share in the 2 years was 5.7%. Bank Vole (*Clethrionomys glareolus*) was represented by 1.8%, House Mouse (*Mus musculus*) by 1.1%. In isolated cases there occurred Common Shrew (*Sorex araneus*).

Birds found in the pellets were not determined to species. They were representatives of the order Passeriformes. Their share in the prey was 0.8%. The share of the individual food components in the pellets is given in detail in Table 1.

No remains of invertebrates were found in the pellets. In 1982 the mean number of vertebrates found in the pellets varied between 1.4 and 2.2 vertebrates per pellet. In 1983 these values varied from 1.7 to 2.6 vertebrates per pellet. These values for the individual sites are given in detail in figures 1 and 2.

For judging the food requirements of the Long-eared Owl I used Shannon's Formula (H) according to Pielou (1969). The value of Shannon's formula is--in the sum for the 2 years--0.3823 at the evenness index of 0.2133. The values for the individual years are given in Table 2.

¹Paper presented at the symposium, Biology and Conservation of Northern Forest Owls, Feb. 3-7, 1987, Winnipeg, Manitoba. USDA Forest Service General Technical Report RM-142.

²Departement of Zoology, Faculty of Sciences
Kotlarska 2
611 37 Brno, Czechoslovakia

Table 1. Contents of Long-eared Owl pellets from all sites.

item	year					
	1982		1983		1982·1983	
	n	%	n	%	n	%
<i>Microtus arvalis</i>	611	87.9	625	92.8	1236	90.3
<i>Apodemus</i> sp.	41	5.8	38	5.6	79	5.7
<i>Clethrionomys glareolus</i>	19	2.7	6	0.8	25	1.8
<i>Mus musculus</i>	16	2.3	0	0	16	1.1
<i>Sorex araneus</i>	0	0	1	0.1	1	0.07
Aves	8	1.1	3	0.4	11	0.8
total	695	99.8	673	99.7	1368	99.7

Table 2. Shannon's index and Evenness index for contents of Long-eared Owl pellets.

	year		
	1982	1983	1982·1983
H'	0.4735	0.2941	0.3823
E	0.2942	0.1827	0.2133

The most important part of the prey consisted of Common Vole and Mouse species. These are the most common species in the agricultural areas of the given region and also are the chief pests.

A high percent of Common Voles in the diet of the Long-eared Owl was found by most authors: Bejček (1980): 86.29%; Boháč and Michálková (1970): 93.10%; Folk (1956): 97.94% for Moravia and 72.60% for Slovakia; Vondráček (1985) 85.10%. These data on the whole correspond to the values found by me. Mice are also listed by Bejček (1980) and Vondráček (1985) as the second most frequent item, but in Bejček the value of percentual representation is twice as high. Bank Voles occurred in pellets at site "C" which is situated in the neighbourhood of the plain forest where the population level of this species is relatively high. Bejček (1980) and Vondráček (1985) did not find Bank Voles in pellets. Folk (1956) writes that the occurrence of this species in the diet of the Long-eared Owl is low.

In the 2 years studied there was a clear supremacy of representatives of the family Microtidae--1261 specimens (92.99%) over representatives of the family Muridae--95 specimens (7.0%).

Figure 1. The mean number of vertebrates in a pellet. A - site near the village of Dolní Němčí. B - site near the village of Hluk.

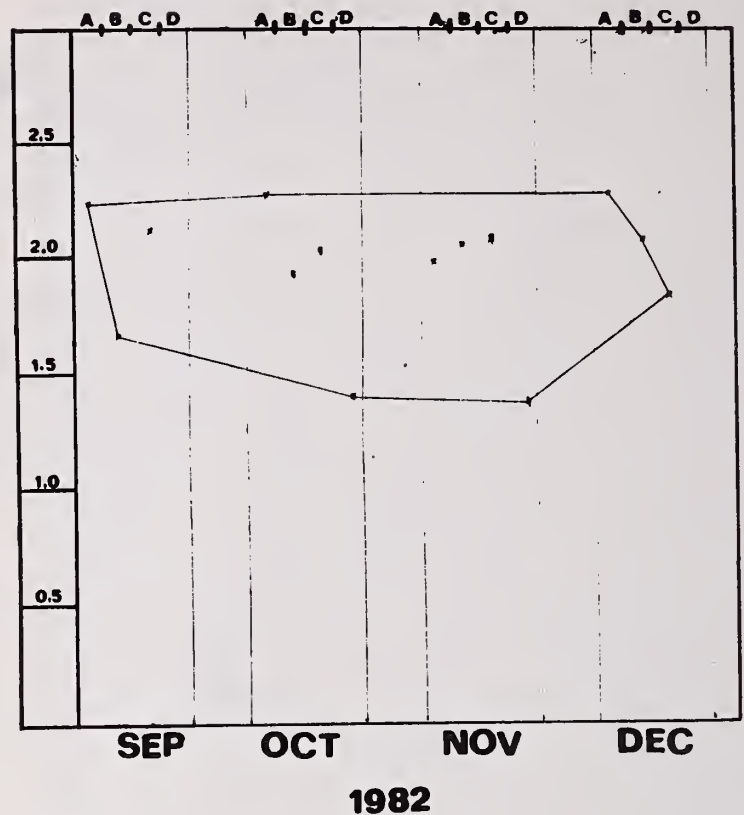
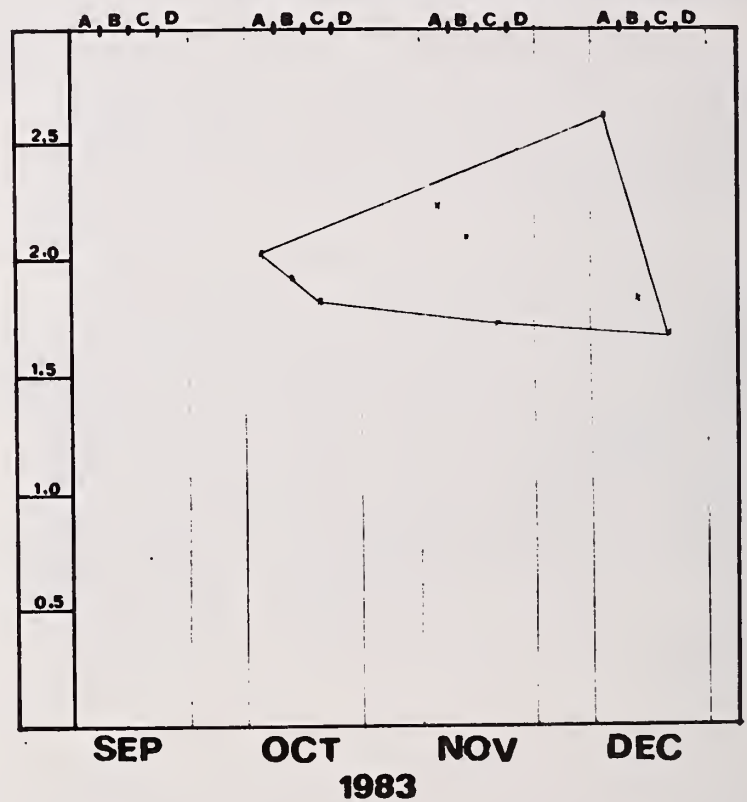

Figure 2. The mean number of vertebrates in a pellet. C - site near the village of Kostelany. D - site near the village of Traplice.



In the opinion of most authors, birds are relatively important in the food of the Long-eared Owl, which was also reflected in my results. The situation is, however, changed in bad weather or during the winter season (Bejček 1980), particularly when owls are concentrated in so-called

winter societies. The above authors show a relatively narrow food spectra for the Long-eared Owl during autumn and winter, but, despite that, the number of food components found in the pellets reaches higher values than those in my case. The very low value of Shannon's formula (0.3823) indicates stenophagy and specialization of the Long-eared Owl to one type of prey. Bejček (1980) found almost twice as high values of Shannon's formula (0.7342) as I at the evenness index of 0.2447.

On the basis of data from the literature, I calculated Shannon's formula (0.6323) and the evenness index (0.2637) from the food found by Vondráček (1985). Different values of Shannon's formula are, in my opinion, due to the effect of the station where the pellets were collected, because the share of the individual food components is directly proportional to the species available in a given environment.

The original reason for the installation of T-shaped wooden perches was to encourage predation activity by birds of prey in selected fields, especially Buzzard species and the Rough-legged Buzzard. Among the collected pellets the highest numbers were those of Long-eared Owls. This means that these artificially installed devices are used by this owl in its hunting strategy.

I wish to thank Čestmír Folk, CSc, for valuable comments on the manuscript.

LITERATURE CITED

- Bejček, V. 1980. K zimní potravě kalouse ušatého, *Asio otus* L. 1758, na Chomutovsku. Sborník Okr. Musea v Mostě. Řada přírodovědná 2, 1980: 53-62.
- Boháč, D. and Michálková, D. 1970. Potrava Kalouse ušatého, *Asio otus*. Sylvia XVIII: 63-71.
- Farsky O. 1928. De l'utilité de quelques oiseaux de proie et Corvidés, déterminée par l'examen de leurs aliments. These de la Faculté des Sciences de Nancy.
- Folk, Č. 1956. Příspěvek k bionomii a potravě kalouse ušatého, *Asio otus*. Zool. listy 5: 271-280.
- Glue, D. E. and G. J. Hammond. 1974. Feeding ecology of the Long-eared Owl in Britain and Ireland. British Birds 67: 361-369.
- Pielou, E. C. 1969. An introduction to mathematical ecology. Wiley, New York.
- Shannon, C. E., and W. Weaver. 1949. The mathematical theory of communication. Univ. Illinois Press, Urbana.
- Vondráček, J. 1985. Příspěvek k zimní potravě kalouša ušatého, *Asio otus* L. Zprávy MOS 43: 73-78.
- Zelený, J. 1961. Potrava kalouse ušatého, *Asio otus* L. v zimním období v Polabí ve středních Čechách. Práce muz. Hradec Králové 2: 245-252.

Fidelity to Territory and Mate in Flammulated Owls¹

Richard T. Reynolds² and Brian D. Linkhart³

Abstract.--Adult flammulated owls were banded on a 452-ha area in Colorado. Nine adults nested 1 year only, five nested in 2 years, four in 3, one in 4, and one in 5. Males had a lower return rate than females. Once males established breeding territories, they returned to them each year. Females sometimes changed territories, and their corresponding dispersal distance (474 m) was similar to the mean distance across territories, 424 m.

INTRODUCTION

Fidelity to a mate or nesting site is widespread among birds, but is particularly common in adults of migratory species that return to breed in the same general area year after year. Fidelity to sites and mates has been studied in some charadriiformes (Wilcox 1959, Lenington and Mace 1975), passeriformes (Delius 1965, Darley et al. 1971, Harvey et al. 1979), seabirds (Coulson 1966, Richdale and Warham 1973, Ollason and Dunnet 1978), and falconiformes (Newton and Marquiss 1982). Little is known, however, about mate and site fidelity in strigiformes, particularly in migratory species.

In general, studies of birds show that males have greater fidelity to territories than do females, and that both males and females more often change territories and mates after a breeding failure than after a success (Greenwood 1980). Harvey et al. (1979) suggested that site fidelity is more likely in species that occupy stable environments, and that mate fidelity is more common among longer-lived species.

We report the annual rate of return to breeding territories, the duration of the pair bond, the frequency of reoccupancy of territories, and the breeding dispersal of flammulated owls nesting in Colorado. Although

we know of no recaptures of banded flammulated owls during migration or in winter, there is extensive evidence that this species is migratory (Jacot 1931, Phillips 1942, Phillips et al. 1964, Sutton 1960, Banks 1964, Phillips et al. 1964, Wolfenden 1970, Hubbard 1972, Balda et al. 1975).

STUDY AREA

This study was conducted on 452-ha of the Manitou Experimental Forest, Teller Co., in central Colorado. The forest on the study tract consisted of open old-growth (200+ yr) stands of ponderosa pine (*Pinus ponderosa*)--Douglas-fir (*Pseudotsuga menziesii*) on south- and west-facing slopes, dense younger (< 100 yr) stands of Douglas-fir--blue spruce (*Picea pungens*) on north aspects, and mixed quaking aspen (*Populus tremuloides*) and blue spruce in the drainages. Elevations ranged from 2550 to 2855 m, with ridges rising 100 to 250 m from bottoms. Trees had not been harvested on the tract since the 1880's (light selective cutting for railroad ties), and snags and cavity trees were relatively common on all slopes (Reynolds et al. 1985). Reynolds et al. (1985) and Reynolds and Linkhart (this volume) described the topography, vegetation, and soils on the study tract.

METHODS

Twenty-one adults were banded on the study tract during 5 nesting seasons (1981-1985). In addition, 9 nestlings were banded in 1981, 9 in 1982, 9 in 1983, 10 in 1984, and 15 in 1985. Three pairs and their nestlings from nests outside of our study tract were banded also. A suite of behavioral characteristics was used to identify the sex of individuals: males by their territorial, courtship, and copulatory behaviors, and high level of activity during nesting; and females by their recipient role in courtship feeding, food-begging behavior, and low level of

¹Paper presented at the Symposium on the Biology and Conservation of Northern Forest owls. [Winnipeg, Manitoba, Canada, February 3-7, 1987].

²Richard T. Reynolds is Research Wildlife Biologist, Rocky Mountain Forest and Range Experiment Station, 222 South 22nd Street, Laramie, Wyoming 82070.

³Brian D. Linkhart is a Wildlife Biologist, 240 West Prospect, Fort Collins, Colorado 80526-2098.

activity during nesting (Reynolds and Linkhart 1984).

Each spring and summer, we searched the entire study tract and some of the surrounding forest for territorial males (Marshall 1939, Winter 1971). Nesting territories and home ranges were identified by marking territorial song trees (Reynolds and Linkhart 1984) and by radio-telemetry (Linkhart et al. in review). Once the boundaries of territories were known, all suitable nest cavities within territories were examined for nesting activity. Because our searches were intensive, we are confident that all nesting pairs and unpaired, territorial males on the study tract were found. All owls except for one pair (A18) and several unpaired, territorial males were captured and banded. We define "territory" as that area used exclusively (Schoener 1968) by a pair or by an unpaired, territorial male. By this definition, because there was no overlapping use of home ranges among flammulated owls (Linkhart et al. in review), home range for this species is synonymous with territory.

RESULTS

Our early spring surveys showed that adult males arrived and established territories during the first week of May (Reynolds and Linkhart this volume). Some females arrived at the same time, but the arrival period of females was longer. For example, we followed an unpaired female as she passed through the tract from south to north giving food solicitation calls on 20 May 1982. Another female was first found on 8 June 1981 in what appeared to be the early stages of pair formation with a previously unattached, territorial male. If young males continued to arrive through May, their arrival went undetected. As many as 6 nesting territories and 3 nonnesting territories on the study tract were occupied by males by the third week of May each year.

The nesting history of 20 of the 21 adults banded during this study was determined. Nine adults nested one year only, 5 returned and nested for two years, 4 for three years, 1 for four, and 1 for five (table 1). Males returned less often than females; banded males returned an average of 1.75 years, while females averaged 2.38 years. The maximum number of seasons an owl returned to nest was 3 years for males and 5 years for females. No birds banded on our tract as nestlings returned to nest or were ever recaptured in subsequent years.

The maximum number of years adults remained paired to the same mate was 3; 10 pairs nested together only 1 year, and 1 pair remained paired for 2 and 1 pair for 3 years. The occupancy of nine nesting territories (MN1 was outside the study tract) through the 5-year study followed a different pattern. One territory was occupied for a single year, three were occupied for 2 years, four for 3 years, and one for 5 years (fig. 1).

Table 1.--Number of years banded flammulated owls nested on the study tract in 5 years, 1981-1985.

Years	No. of males	No. of females	Total
1	6	3	9
2	3	2	5
3	3	1	4
4	0	1	1
5	0	1	1

On six of the nine nesting territories, either the adult male or the female (in one case both adults) was replaced by a new male or female once or twice during the 5-year study (table 2, fig. 1). In none of these cases did an adult male move from one territory to another within our study tract--each replacement male

YEAR	TERRITORY									
	A39	A15	A4	A24	A29	A12	A10	A18	A11	MN1
1981	M-F		M-F	M-F	M-F	M-F	M	M-F		
1982		M-F	M-F	M-F	M-F	M	M-F	M		M-F
1983			M-F	M-F	M-F	M		M	M-F	M-F
1984		M-F			M-F	M-F		M-F	M-F	
1985	M-F				M-F	M-F		M	M-F	

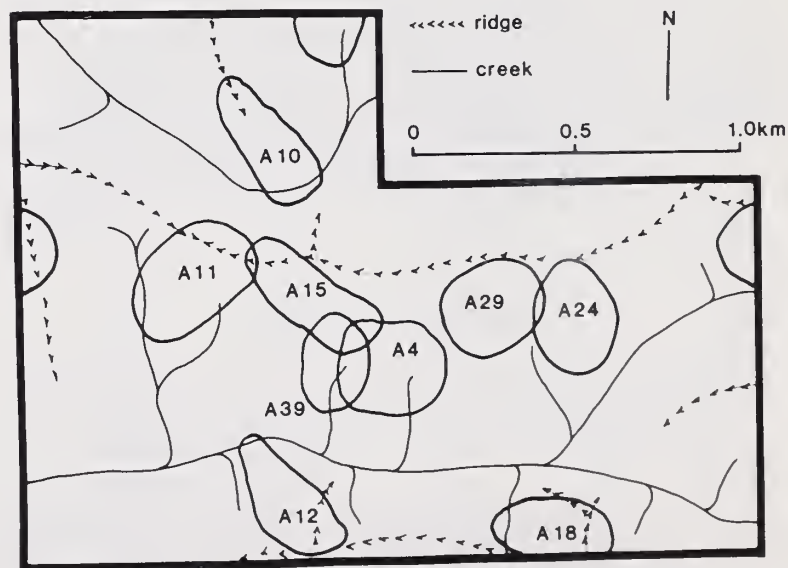

Figure 1.--Fidelity to mate and territory, female breeding dispersal, and schematic of study tract showing approximate boundaries of territories. Unmarked peripheral territories were occupied by unidentified male owls. Territory MN1 did not occur on tract (see text).

was unbanded. In contrast, 4 of the 7 female replacements were banded adults that had nested elsewhere on the study tract in a previous year. In one case, a female (originally A39) nested 3 consecutive years on the tract in different but adjacent territories (fig. 1). In another case, two females (originally A29-83 and A15-84) nested with a male on his (A12) territory in 2 consecutive years (female A29 in 1984 and female A15 in 1985). The overall replacement rate (total replacements per year for all territories) was 22.2% for males and 38.9% for females. Thus, even though males have a lesser chance of returning to nest than females, males were replaced less often on a territory.

Breeding dispersal (Greenwood 1980) is the distance moved by an individual owl between its nest of one year (either the first or subsequent nestings) and the nest of the following year. Two categories of movements by flammulated owls between years were noted. The first category (3 cases) involved the same pair, or at least the same male of the pair, moving (\bar{x} = 71.7 m, SD = 44.2, range 30-118 m) to a different nest tree from one year to the next, but staying within an existing territory. Because these movements occurred within a territory, they were not considered breeding dispersal. The second category involved the changing of territories between years. This dispersal occurred only among females (5 of 10 that returned to nest) and averaged 474 m (SD = 201.8, range 256-798 m) (fig. 1). The mean dispersal distance was only slightly greater than the mean distance across the measured home ranges (424 m) (Linkhart et

al., in review). Thus, on average, females dispersed to adjacent territories. Harvey et al. (1979) found that great tits (*Parus major*) in England also dispersed the distance of a territory's width.

The proximate reasons for dispersal of females could not be determined; however, in all but one case, the original male at the abandoned territory had not returned. The exception involved a male (A12) who was unpaired for at least 1 year (1983) but who nested the following 2 years in the same territory but with different females (fig. 1). The original female (A29-83) had dispersed (798 m) to this territory in 1984, and the second female (A15-84) dispersed 495 m to the territory the following year (1985). There was no evidence that the first female (A29-83) returned to the study tract in 1985. Also, all but one dispersing female paired with an experienced male. In 1984, the male of A29-83 did not return and was replaced by an unbanded male (A29-84) who had paired with female A24-83 from an adjacent territory. The nest of A24 female had failed in 1983, and the fate of her original male was unknown. In only this case did a previously nesting female disperse to pair with a first-time nesting male--all other dispersals were to territories of males that had either nested, or were at least presumed to be the same male that defended a territory (e.g., A12), in previous years.

The nesting success of pairs (number of fledglings) may be related to the nesting experience of adults (table 3). Pairs consisting of males and females known to be nesting for the first time had an average of 0.58 fewer ($t = -2.02$, $df = 8$, $p < 0.1$) fledglings than pairs consisting of males and females known to have nested previously. If this relationship exists, there is a reproductive advantage for a male to return to its previous territory and for a female to choose an experienced male. We assumed that birds nesting for the first time on the tract were first-time breeders. The strength of our assumption obviously depends on the size of a study area and the likelihood that males in fact are not long-distance dispersers. However, because females are known to change territories, they may have dispersed onto the tract after nesting elsewhere. As a result, the category of first-time nesting females in the table may actually include experienced breeders. If so, any differences in brood size between experience categories would be diluted.

DISCUSSION

As in many other birds, flammulated owls demonstrated a marked between-year site fidelity, with males showing more faithfulness than females. The apparent absence of breeding dispersal in male flammulated owls may be related to the benefits accrued to males who establish territories in areas where they have had previous experience with the spatial and temporal variation in resources. Previous

Table 2.--The number of known replacement males and females on territories used more than once.

Territory	Males		Females	
	Replacement	Opportunities ¹	Replacement	Opportunities ¹
A24	0	2	0	2
A29	1	4	1 ²	4
A4	1	2	1 ²	2
A39	1	2	1	2
A15	1	2	1 ²	2
A12	0	3	2 ³	3
A11	0	2	1	2
MN1	0	1	0	1
Total	4	18	7	18

¹Opportunities is the number of years that a territory was reoccupied by any male or female. Tally was not limited to territories reoccupied in consecutive years.

²Involved a female changing territories between years.

³Involved two females changing territories between years.

Table 3.--Relationship between male and female nesting experience and productivity (number of fledglings). Three pairs that nested in 1986 are included.

	Number of fledglings			
	Males breeding 1st yr ¹		Males breeding > 2 yr ²	
	\bar{x} (SD)	n	\bar{x} (SD)	n
Females breeding 1st yr ¹	2.25 (0.50)	4	2.50 (0.71)	2
Females breeding > 2 yr ²	2.67 (0.58)	3	2.83 (0.41)	6
Combined	2.43 (0.53)	7	2.75 (0.46)	8

¹Males and females in the first yr are assumed to be first-time nesting birds (see text).

²Males and females nesting 2 or more yrs are birds known to have previous nesting experience.

experience may also predispose them to better establish and defend territories.

Because female flammulated owls are not involved in territorial defense and their role is primarily one of incubating and brooding (Reynolds and Linkhart this volume), they should pair with males already established in suitable habitat. If, upon return to their territory in the spring, their previous mate has not returned, females should immediately abandon that territory and pair with another male in suitable habitat. If nesting success is related to nesting experience, then a dispersing female should choose an experienced male with which to pair. If a female can recognize the voice of neighboring males from previous years, she could likely identify an experienced male in territories adjacent to her previous territory; that is, female breeding dispersal should be on the order of the width of 1-2 breeding territories. That females have the opportunity to judge the success of adjacent pairs is demonstrated by the occasional visits females made to the nests of adjacent pairs.

Species composition and structure of the forests on our study tract undergo relatively little change within the life span of individual flammulated owls. Site fidelity is expected to be prevalent among species living in stable environments (Harvey et al. 1979). Also, sexual differences in dispersal distances is likely to occur in species in which territorial establishment and defense is the duty of one sex and where success of the territorial defender is enhanced by retention of the same breeding area from year to year (Greenwood and Harvey 1976). In flammulated owls, it appears that competition among males for females is mediated through the ability of males to gain and hold a territory. Females do not have the costly constraint of establishing and defending territories. They do, however, have the option of choosing between available territories and/or males, provided they arrive on the nesting grounds early enough--that is, while there still are available

males.

Young males attempting to establish territories for the first time may be forced to occupy less suitable habitat and may remain unpaired until suitable habitat becomes available. In fact, we found unpaired, territorial males in small patches of old-growth ponderosa pine--Douglas-fir on the periphery and outside of our study tract. These males were difficult to capture and were not banded. Because of this, it was not known if the replacement males on our study tract were formerly peripheral males which had moved into vacated nesting territories. However, if young, inexperienced males occupied less suitable habitat for one or more seasons, this could account for the lower return of males compared to females--males may already be 2-3 years old before they gain breeding territories.

ACKNOWLEDGEMENTS

We thank J. Jeanson for help with finding, capturing, and marking flammulated owls, and G. Crouch, T. Gavin, R. Goggins, R. King, W. Mannan, and R. Ryder for reviewing the manuscript.

LITERATURE CITED

- Balda, R. P., B. C. McKnight, and C. D. Johnson. 1975. Flammulated owl migration in the southwestern United States. *Wilson Bulletin* 87:520-533.
- Banks, R. C. 1964. An experiment on a flammulated owl. *Condor* 66:79.
- Coulson, J. C. 1966. The influence of the pair-bond and age on the breeding biology of the kittiwake gull *Rissa tridactyla*. *Journal of Animal Ecology* 35:269-279.
- Darley, J. A., D. M. Scott, and N. K. Taylor. 1971. Territorial fidelity of catbirds. *Canadian Journal of Zoology* 49:1465-1478.
- Delius, J. D. 1965. A population study of

- skylarks *Alanda arvensis*. *Ibis* 107: 466-492.
- Greenwood, P. J. 1980. Mating systems, philopatry, and dispersal in birds and mammals. *Animal Behavior* 28:1140-1162.
- Greenwood, P. J., and P. H. Harvey. 1976. The adaptive significance of variation in breeding area fidelity of the blackbird (*Turdus merula* L.). *Journal of Animal Ecology* 45:887-898.
- Harvey, P. H., P. J. Greenwood, and C. M. Perrius. 1979. Breeding area fidelity of great tits (*Parus major*). *Journal of Animal Ecology* 48:305-313.
- Hubbard, J. P. 1972. King rail and flammulated owl at El Paso, Texas. *Condor* 74:481.
- Jacot, E. C. 1931. Notes on the spotted and flammulated screech owls in Arizona. *Condor* 33:8-11.
- Lenington, S., and T. Mace. 1975. Mate fidelity and nesting site tenacity in the killdeer. *Auk* 92:149-151.
- Marshall, J. T., Jr. 1939. Territorial behavior of the flammulated screech owl. *Condor* 41:71-78.
- Newton, I., and M. Marquiss. 1982. Fidelity to breeding area and mate in sparrowhawks *Accipiter nisus*. *Journal of Animal Ecology* 51:327-341.
- Ollason, J. C., and G. M. Dunnet. 1978. Age, experience, and other factors affecting the breeding success of the fulmar, *Fulmarus glacialis*, in Orkney. *Journal of Animal Ecology* 47:961-976.
- Phillips, A. R. 1942. Notes on the migration of the elf and flammulated screech owls. *Wilson Bulletin* 54:132-137.
- Phillips, A. R., J. Marshall, Jr., and C. Manson. 1964. *The birds of Arizona*. University of Arizona Press, Tucson.
- Reynolds, R. T., and B. D. Linkhart. 1984. Methods and materials for capturing and monitoring flammulated owls. *Great Basin Naturalist* 44:49-51.
- Reynolds, R. T., and B. D. Linkhart. 1987. The nesting biology of flammulated owls in Colorado. Symposium on the Biology and Conservation of Northern Forest Owls, Winnipeg, Manitoba, Canada, February 3-7.
- Reynolds, R. T., B. D. Linkhart, and J. Jeanson. 1985. Characteristics of snags and trees containing cavities in a Colorado conifer forest. USDA Forest Service, Rocky Mountain Forest and Range Experiment Station. Research Note RM-455, 6 p.
- Richdale, L. E., and J. Warham. 1973. Survival, pair bond retention, and nest-site tenacity in buller's molly mawk. *Ibis* 115:257-263.
- Schoener, T. W. 1968. Sizes of feeding territories among birds. *Ecology* 49:123-141.
- Sutton, G. M. 1960. Flammulated owl in Lubbock County, Texas. *Southwest Naturalist* 5:173-174.
- Wilcox, L. 1959. A twenty-year study of the piping plover. *Auk* 76:129-152.
- Winter, J. 1971. Some critical notes on finding and seeing the flammulated owl. *Birding* 3:205-209.
- Wolfenden, G. E. 1970. A putative skeletal specimen of the flammulated owl with Alabama locality data. *Wilson Bulletin* 82:223-224.

The Nesting Biology of Flammulated Owls in Colorado¹

Richard T. Reynolds² and Brian D. Linkhart³

Abstract.--Spring arrival of flammulated owls to a 452-ha area in Colorado occurred in early May. Each year, 4-6 territories were occupied by pairs and 2-3 territories by unpaired males. Clutch size was 2.7 eggs, incubation was 22 nights, brood size was 2.4 young, and young were in the nest 23 nights. Owlets dispersed in late August and adults in early October. The affinity of flammulated owls for old yellow pine forests stems from the abundance of nest cavities, the structure of the trees and stands, and the arthropods found in these forests.

INTRODUCTION

The flammulated owl (*Otus flammeolus* [Kamp]) is a little known insectivorous species (Ross 1969) that is widely distributed in montane forests from southern British Columbia southward through the highlands of Mexico and Guatemala (Bent 1938). The owl is one of the smallest in this region (Earhart and Johnson 1970), is an obligate cavity-nester, and is assumed to be migratory in the northern part of its range (Marshall 1957, Winter 1974, Balda et al. 1975). It breeds from the Rocky Mountains (Reynolds and Linkhart 1984, and others) to the Pacific (Winter 1974) and from southern British Columbia (Cannings et al. 1978) south to Vera Cruz, Mexico (Sutton and Burleigh 1940). The winter range is thought to be from Guatemala and El Salvador north to Jalisco, Mexico (Phillips et al. 1942).

In spite of its wide distribution, little is known of the flammulated owl's nesting biology and population status. In fact, its status is so obscure that gross population changes would remain undetected.

Flammulated owls typically are found in the yellow pine belt--from lower elevations where the pine is mixed with oak (*Quercus* sp.) (Marshall 1957, Marcot and Hill 1980) or pinyon pine (*Pinus monophylla*) (Huey 1932) to its upper

reaches where the pine mixes with firs (*Abies* sp.), Douglas-fir (*Pseudotsuga menziesii*), larch (*Larix* sp.), or incense-cedar (*Libocedrus decurrens*) (Marshall 1939, Phillips et al. 1964, Johnson and Russell 1962, Bull and Anderson 1978, Reynolds and Linkhart 1984). The owl also has been recorded in quaking aspen (*Populus tremuloides*) (Webb 1982) and second-growth ponderosa pine (*P. ponderosa*) (Winter 1974). However, only Bull and Anderson (1978), Reynolds and Linkhart (1984), and Goggins (1986) extensively searched for nests, and only Reynolds and Linkhart (1984) estimated the density of nesting pairs. The owl's preference to forage in old-growth (> 200 yr old) ponderosa pine-Douglas-fir stands (Linkhart et al. in review)--a type and age class that is extensively managed in North America--its dependence on cavities for nests, and reports that the owl is not found in cutover forests (Marshall 1957, Phillips et al. 1964, Franzreb and Ohmart 1978) suggest a critical need for information about its nesting biology, nesting density, and habitat affinities.

We studied flammulated owls in the montane forest in central Colorado from 1980 to 1986 (Reynolds and Linkhart 1984, this volume; Linkhart and Reynolds, in press; Linkhart et al., in review). Nesting pairs and non-nesting territorial males on the study tract, as well as several pairs outside the tract, were studied each year. Movements and habitat use by nesting owls were determined with radio-telemetry in 1982-1983. Here we report the density of territorial males, territorial and nesting behavior, productivity, and foraging, and discuss the habitat associations of this owl.

STUDY AREA

The study was conducted on a 452-ha area of the Manitou Experimental Forest in central Colorado. Forest on the study tract consisted

¹Paper presented at the Symposium on the Biology and Conservation of Northern Forest Owls. [Winnipeg, Manitoba, Canada, February 3-7, 1987].

²Richard T. Reynolds is Research Wildlife Biologist, Rocky Mountain Forest and Range Experiment Station, 222 South 22nd Street, Laramie, Wyoming 82070.

³Brian D. Linkhart is a Wildlife Biologist, 240 West Prospect, Fort Collins, Colorado 80526-2098.

of open, park-like stands of ponderosa pine mixed with Douglas-fir on south- and west-facing slopes, dense stands of Douglas-fir mixed with blue spruce (*Picea pungens*) on north aspects, limber pine (*P. flexilis*) mixed with ponderosa pine and Douglas-fir on ridgetops, and quaking aspen mixed with blue spruce in drainage bottoms. Ages of the forest stands on the tract, as well as on the surrounding slopes, were mature (100-200 yr) to old-growth (200+ yr), but stands of second-growth (< 100 yr) occurred on most north-facing slopes.

Understories on slopes consisted of shrubs, such as common juniper (*Juniperus communis*), kinnikinnik (*Arctostaphylos uva-ursi*), cliffbush (*Jamesia americana*), and numerous grasses and forbs (Reynolds et al. 1985). Understories in creek bottoms consisted of willow (*Salix* spp.), water birch (*Betula occidentalis*), Rocky Mountain maple (*Acer glabrum*), grasses, and forbs. Elevations ranged from 2,550 to 2,855 m. The tract had not been logged since the 1880's, and snags (many containing suitable nesting cavities) were common on all slopes and aspects (Reynolds et al. 1985). Scattered snow drifts remained on the tract into early May, and a light to heavy snow fell 1-3 times per week through the month of May. Mean nightly low temperatures (taken in 1983) were -1.7° C for May, 2.8 for June, 7.3 for July, 7.9 for August, 2.2 for September, and -1.6 for October.

METHODS

Owls were observed from early May to mid-October, 1980-1985, and during 1 week in mid-July in 1986. Behavior was used to identify the sex of owls: males by their courtship feeding, copulatory and territorial behavior, and high level of activity during nesting; females by their recipient role in courtship feeding, food-begging vocalizations, and low level of activity during nesting (Reynolds and Linkhart 1984, Linkhart et al. in review). The sex of owlets was not determined.

Breeding adults were located from early May to late July by imitating their territorial song (Marshall 1939, Winter 1971, Marcot and Hill 1980). Prior to egg-laying, adults were located by their courtship vocalizations. Territory boundaries were identified by marking the song trees of singing males (after Wiens 1969). Once territory boundaries were known, all tree cavities with entrance diameters greater than 4 cm were checked for nesting owls (Reynolds and Linkhart 1984). Incubation period was the time (nights) from laying to hatching of the last egg. Fledged young were located by their food-begging vocalization, calls of attendant adults, and radio-tagged individuals (Reynolds and Linkhart 1984, Linkhart et al. in review).

Radio-telemetry was used to determine home range size, foraging locations, and activity of owls in 1982-1983 (Linkhart et al. in review). Capture of owls is described by Reynolds and

Linkhart (1984). Males were equipped with tail-mounted or backpack-mounted transmitters (3.0 g) shortly after egg-laying, and females and young were equipped with backpack-mounted transmitters (Reynolds and Linkhart 1984). We followed the radio-tagged owls with a portable radio-receiver and hand-held yagi antenna.

Composition of diets and frequency of food delivery were determined by observing males delivering food to females during courtship and later to nests. Observations at nests were facilitated by gasoline lanterns, binoculars, and cameras placed adjacent to nest cavities (Reynolds and Linkhart 1984).

Foraging behavior was determined by observing radio-tagged owls and incidental observations of nonradioed owls. The rate of food delivery during courtship, incubation, and nestling stages was determined during 61 observation bouts (total 97 hr) between 20:30-03:00 hr MDT from 1981-1984 (16 hr during courtship for 9 pairs, 26 hr during incubation at 8 nests, and 55 hr during the nestling stage at 12 nests). Mean length of observation bouts was 1.6 hr (SD = 0.90, range = 0.5-3.9). Hourly delivery rates were calculated by dividing the total number of deliveries tallied per hour per night at nests by total hours of observation at nests. Hourly rates were grouped in 4-night intervals, and a mean hourly rate among the 4 nights was calculated. This procedure was used to determine the delivery rates during courtship and incubation stages.

Because females were fed in the cavities for only the first 12 nights of the nestling stage, and brood size varied among nests (2-3 nestlings), the delivery rate during the nestling stage could not be determined directly. To estimate the rate after hatching, we first assumed that females consume two arthropods per hour during the 12 days after hatch (the delivery rate during the last days of incubation). We then subtracted two deliveries per hour per female from the total deliveries tallied during a night's observations. The remaining number of deliveries then was divided by the number of young being fed, and a mean hourly rate per young for each 4-night period was determined as above. A delivery rate for a brood of three was estimated by multiplying the mean hourly rate per young by 3.

Body mass of adults and owlets were determined to the nearest 0.5 g with Pesola spring scales. No attempt was made to adjust for stomach contents. Adults were weighed at night after some foraging had occurred. Nestlings were weighed in the latter half of the diurnal fasting period. We examined seasonal lability of body mass using mean weights of owls captured during the stages of nesting. Seasonal changes in mass of individuals, for which we had repeated measures, mimicked the seasonal patterns of the means.

Nocturnal flying insects on the study tract were sampled during the summer of 1981 and 1982 using a battery-powered (12-volt) black-light trap fitted with a photo-sensitive cell. The trap was operated at a lower-slope position for 1 to 3 nights/week from 20 May-27 August 1981 and 1-2 nights/week between 18 May and 29 September 1982. Traps were cleaned each morning. Specimens of each species were pinned, and the number of individuals per family per night counted.

In the summer of 1980, we placed 17 nest boxes (see Gary and Morris 1980 for dimensions) within the home ranges of six males. Boxes were placed below the crowns on trunks of large-diameter trees (all between 3-4 m high).

RESULTS

Spring Arrival, Pair Formation, and Territoriality

Some adult males appeared on territories as early as the first week of May, and all territories were occupied by the third week of May. Although some females arrived in early May, they appeared to arrive over a longer period than males. A few owls, apparently already paired, were observed as early as 3 May at nests used in previous years. Nesting males sang frequently during the incubation period, but less often after the eggs hatched. Territorial males that remained unpaired sang throughout the summer.



Foraging habitat of Flammulated Owls on the Manitou Experimental Forest.

During the courtship period, pairs moved through their territories visiting prospective nest-cavities. Males entered cavities and gave quiet, hoarse "boop-boop" calls once inside. Females followed males into cavities. After a nest tree had been selected (usually by late May), females remained in the close vicinity of the tree. During courtship feeding, males approached females and gave quiet "boop-boop" calls to which females responded with food-begging ("meow") vocalizations. Males then perched next to females and transferred food to them. Copulation, when it occurred, usually followed food transfers. On several occasions, the birds preened one another after copulating.

Each year, four to six nesting territories and two to three non-nesting territories were occupied on the tract (0.9-1.3 nests/100 ha and a maximum of 2 territorial males/100 ha). Counts of singing males in other areas ranged from 1 to 5 males per 40 ha (Marshall 1939, Winter 1974, Balda 1977, Franzreb and Ohmart 1978). Five territories were on the south-facing slope of the principal ridge running east to west through the tract, and during the years from 1981 to 1985, each of these five territories was occupied by pairs a mean of 3.0 yr (SD = 1.22, range = 2-5) (Reynolds and Linkhart, this volume). This south-facing slope had a continuous cover of old-growth ponderosa pine mixed with Douglas-fir. Two nesting territories in the northwest quarter of the tract contained a mosaic of stands of old-growth ponderosa pine--Douglas-fir, mature quaking aspen--blue spruce, and mature quaking aspen. One of these territories (A10) was occupied for a single year, and the other (A11) was occupied for 3 years (1983-1985) by the same male.

Two nesting territories were located in old-growth ponderosa pine--Douglas-fir on the upper portions of west-facing slopes of terminal ridges along the southern boundary of the tract. The area of old-growth in each was restricted; both territories were bounded below by young stands of Douglas-fir mixed with blue spruce. One of these territories (A18) was occupied by a nesting pair in 1981 and 1984 and an unpaired male in other years. The other territory (A12) was occupied by a courting pair in late spring of 1981. Although their nest was not located, the pair probably produced a clutch. In 1982 and 1983, this territory was occupied by an unpaired male. In 1984-1986, a male occupying this territory nested in trees in a creek bottom in the extreme northwest portion of his range. Observations of the male showed that he departed and arrived at the nest with food from the center of his territory on top of the ridge. In 1982, another pair nested on the periphery of a territory that had been occupied in 1980 and 1981 by an unpaired male. This pair (A10) nested in a quaking aspen in a creek bottom in the extreme southeast portion of the territory. The radio-tagged male primarily foraged 400 m to the northwest of the nest in old-growth ponderosa pine--Douglas-fir.

Observations indicate that males may expand their territories when adjacent territories are not occupied. Territory A24 contained a nesting pair during 1981-1983. In 1984 and 1985, A24 was not occupied, and a banded male from an adjacent territory (A29) day-roosted in the nest area of A24 during late summer and fall of both years (see fig 1, Reynolds and Linkhart, this volume). In 1982, territory A15 was occupied by a radio-tagged male who used the northern part of unoccupied territory A39. In 1983, a radio-tagged male in territory A4 used the eastern parts of unoccupied territories A39 and A15. Territory A39 was occupied in 1985 and 1986 while A4 and A15 were not. In 1986, the male in A39 nested 150 m to the east of his 1985 nest in a tree adjacent to the western-most nest of A4. In no year were all three of these territories occupied simultaneously.

In the 6 years (1981-1986) that nest boxes were available on our study tract, 2 of the 17 were used; a pair in territory A4 produced two fledglings in 1983 and a pair in A39 produced three fledglings in 1985. Use of nest boxes by flammulated owls in other areas has been reported (Hasenyager et al. 1979, Cannings 1982, Bloom 1983).

Nesting Chronology and Productivity

Mean clutch size for 11 pairs from 1981-1985 was 2.7 eggs (SD = 0.47, range = 2-3, mode = 3). The interval between laying of the first and second eggs was undetermined, but two nights elapsed between laying of the second and third eggs for two females. The mean date of clutch completion (the laying of the last egg) for 14 females was 7 June (SD = 4.6, range = 29 May-14 June). Observations at one nest indicate that incubation began after the second egg was laid. At this nest, two eggs were on opposite sides of the nest cavity on 8 June 1982 and the female was day-roosting on the floor of the cavity. On 9 June, the female sat tightly on the eggs, which had been moved to the center of the cavity. The clutch contained three eggs on the night of 10 June, and all eggs were touching one another.

The incubation period, determined for three clutches whose laying and hatching dates were known, was 22 nights (SD = 0.6, range = 21-22). All clutches hatched over two nights. The mean date on which the last egg hatched in 14 clutches was 29 June (SD = 4.6, range = 20 June-6 July). Mean size of 26 broods was 2.4 young (SD = 0.80, range = 1-3), and for 23 successful nests the mean number of fledglings per nest was 2.6 (SD = 0.59, range = 1-3). Mean length of the nestling period, determined for five broods, was 23 nights (SD = 1.1, range = 22-24), and mean fledging date for 14 broods was 22 July (SD = 4.5, range = 13-29 July). Broods fledged over two nights, and all broods separated shortly after fledging, with one portion of the brood being tended by the male and the other by the female (Linkhart and Reynolds, in press).

Owlets were foraging successfully and no longer provisioned with food by late August, 25-32 nights after fledging.

Sex Roles, Food, and Foraging

As in other strigiforms, there is a division of labor between the sexes in flammulated owls. Females were fed by males for 2 to 3 weeks (beginning as early as 23 May) prior to egg laying. Although we did not determine exactly when females ceased foraging, we never observed them doing so after courtship feeding began. In the few nights prior to laying, females spent the entire night perched within 20 m of the nest-cavity and were fed at high rates by males. Female body mass increased by as much as 68% before laying (see below). Females did all of the incubating and brooding. On the tenth or eleventh night after hatch, females began foraging and, through the remainder of the nestling stage, gradually increased the number of foraging trips. At the time of fledging, females had resumed foraging full-time.

Flammulated owls were entirely insectivorous (also see Ross 1969); most food items delivered to nests or fledglings were small- to medium-sized moths (mostly Noctuidae). However, by midsummer, the owls also captured various lepidopteran larvae, orthopterans, coleopterans, spiders, and other arthropods. When adults delivered food to nests or fledged young, they always brought one prey at a time.

Adults used four foraging tactics: hawk-gleaning, hover-gleaning, hawking, and drop-pouncing. Hawk-gleaning, which occurred inside the crowns of trees, consisted of flying from a perch inside the crown to take resting arthropods from branches, trunks, or inner portions of needle bunches. Hover-gleaning consisted of an owl flying from a perch in one tree to glean moths from the outer needles of adjacent crowns while hovering. Both hawk-gleaning and hover-gleaning, the most frequently used tactics, occurred in the more open lower two-thirds of tree crowns. From the middle of summer, and especially in late summer, adults and fledglings frequently dropped from the lower portions of a tree crown to pounce on arthropods on the ground, grasses, or shrubs. Hawking, the least frequently used tactic, occurred either within crowns or in the spaces between crowns and consisted of an owl leaving a perch to capture a flying insect and returning to a new perch.

Individuals of the lepidopteran family Noctuidae were by far the most abundant moths in the black-light trap samples during May-September (fig. 1). These moths never contributed less than 67% of the total catch in any month during the sample periods in 1981 and 1982. Only two other families, Sphingidae and Geometridae, were common in the samples; sphingids in the spring and early summer (a high of 18% in May) and geometrids in August (high of

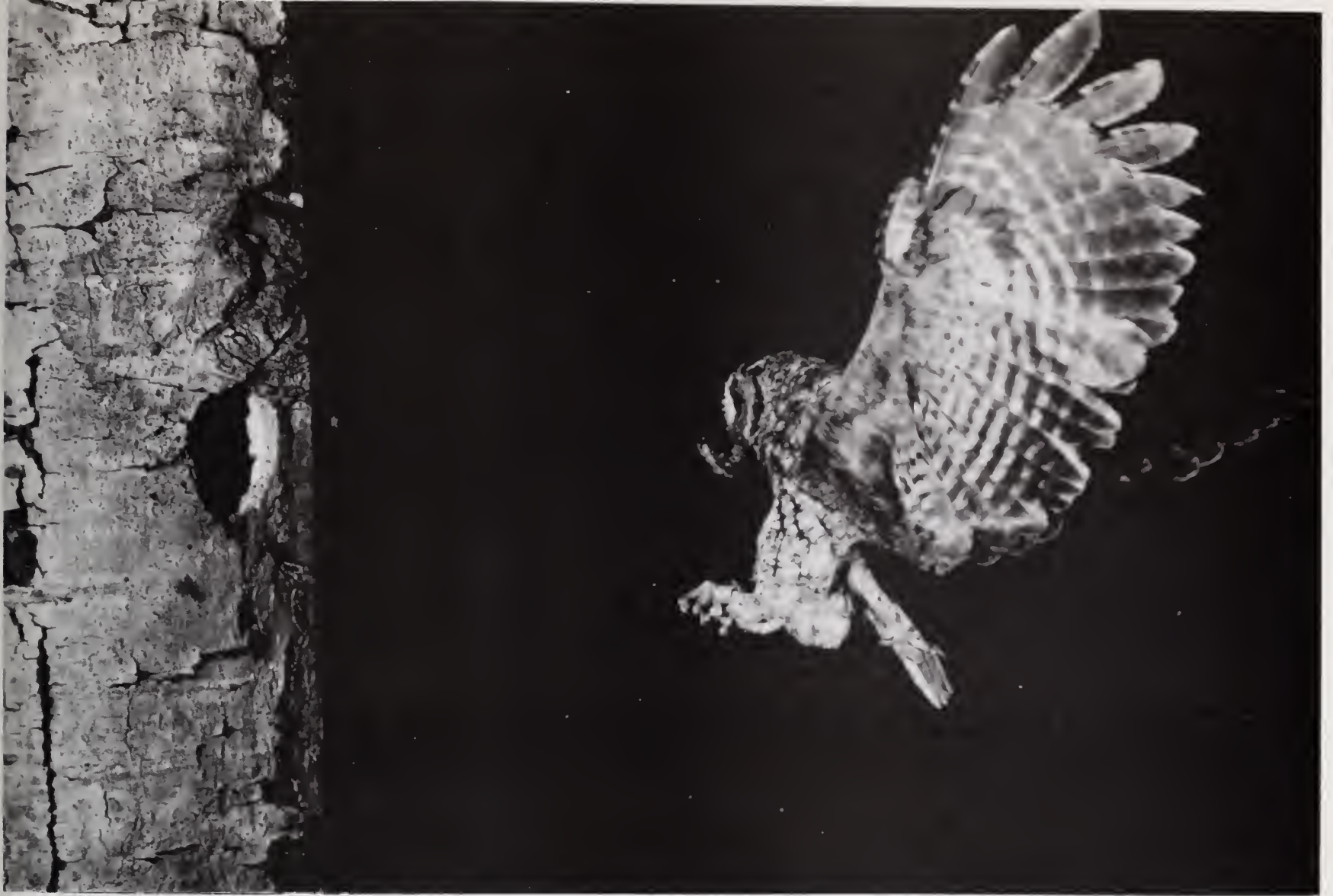

The male Flammulated Owl always delivered a single prey item at a time to the nest.

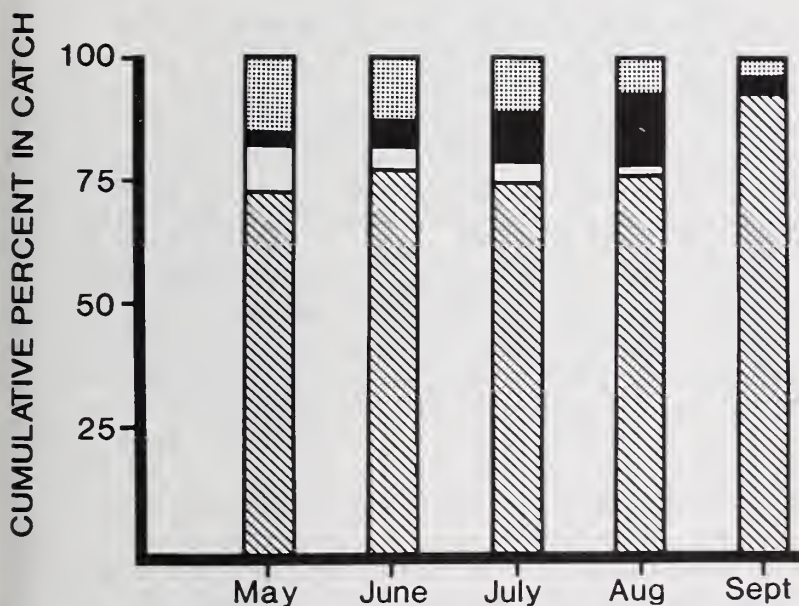

Figure 1.--Percent composition of lepidopteran (moth) families in black-light trap. Data are percentages of combined (1981 and 1982) catch by month. Striped bars = Noctuidae, open = Sphingidae, dark = Geometridae, stippled = all their families (Arctiidae, Saturniidae, Notodontidae, Lasiocampidae, Lithosciidae, Ethmiidae, Pyralidae, Tortricidae, Limnophilidae). Total combined catch for May = 472 moths, June = 2,710, July = 4,973, August = 1,970, September = 203.

17%). Members of "all other families" were abundant in May, but their combined relative frequency declined as summer progressed. On our study tract, noctuids appeared to be the only food available to the owls during cold spring nights. These moths generally are robust, nocturnal insects with strong flight capabilities and were frequently seen in May flying about the forest canopy when temperatures were below freezing.

Seven nesting home ranges averaged 14.1 ha. Although owls foraged throughout these ranges, each range had 1 to 4 areas within which foraging by males was concentrated; 81% of 221 observed foraging attempts occurred in these intensive foraging areas (IFAs) (Linkhart et al., in review). Mean total area in IFAs within ranges was 1.0 ha (range = 0.6-1.5), and all but 1 of the 7 nests were contained within an IFA. Mean distance from nests to IFA centers was 125 m (range = 10-410). Of the 15 IFAs, 12 contained old-growth ponderosa pine--Douglas-fir, 2 contained mature quaking aspen--blue spruce, and 1 a mix of old-growth ponderosa pine--Douglas-fir and mature aspen. Although the behavior was not quantified, we observed males foraging in IFAs nearest their nests during bursts of foraging activity in the early evenings (see below) and at other times when food demands at nests were high. Males foraged

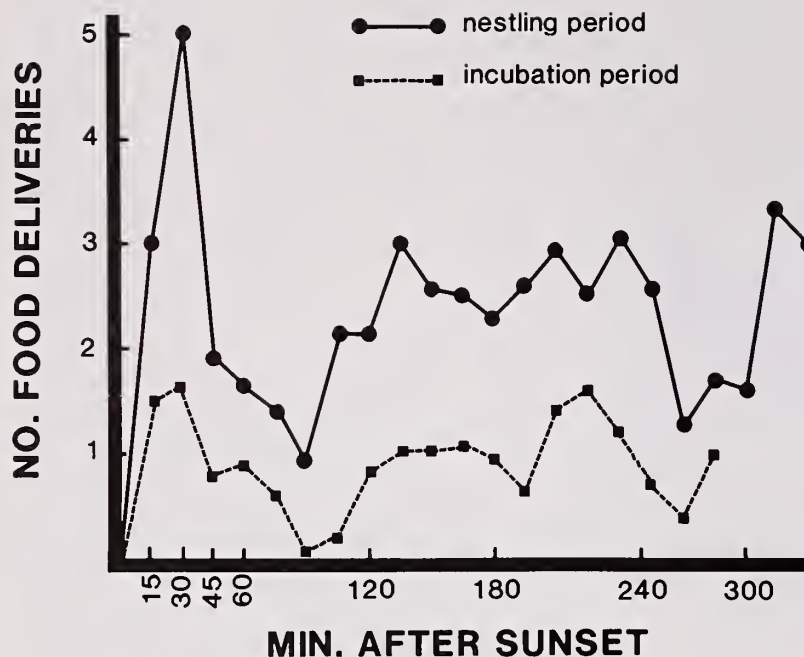

Figure 2.--The number of food deliveries to nests in 15-min. periods during incubation and nestling stages. Observations began at 20:30 hr and ended at 03:00 hr MDT, and were made at 8 nests (total 26 hr) during incubation and at 12 nests (total 55 hr) during the nestling stage.

in more distant IFAs when rates of food delivery to nests were low.

The pattern of nightly food deliveries by males during courtship and nesting was a burst of feeding activity 15-30 min after sunset, followed by a decline over the next hour, and then a return to an intermediate level for the remainder of the observation period (fig. 2). Observations at nests terminated at 03:00 hr, but radio-tracking of foraging males showed that the delivery rate continued at the intermediate level through the late night, and that another burst of food deliveries took place 1-1.5 hr before sunrise. Males stopped foraging and went to roost about 0.5 hr before sunrise. This pattern of food delivery was essentially the same at all stages of the nesting cycle, the only difference being the rate. A similar pattern was found for a single pair of flammulated owls in Idaho from hatching through the first two-thirds of the nestling period (Hayward 1986).

Nightly delivery rates from courtship through the nestling stages (fig. 3) show patterns associated with expected energy demands at each stage of the cycle. From the beginning of courtship feeding, males increased the rate of feeding of females to almost 12 moths per hr in the 4 days prior to laying the first egg--an increase associated with the energy demands of egg formation. After laying, food deliveries decreased to a low of about two moths per hour the 8 days prior to hatching. After hatching, the delivery rate increased and peaked at over 16 trips/hr during the period 8-12 days after hatch. It was at the end of this period that females began foraging. The subsequent decrease

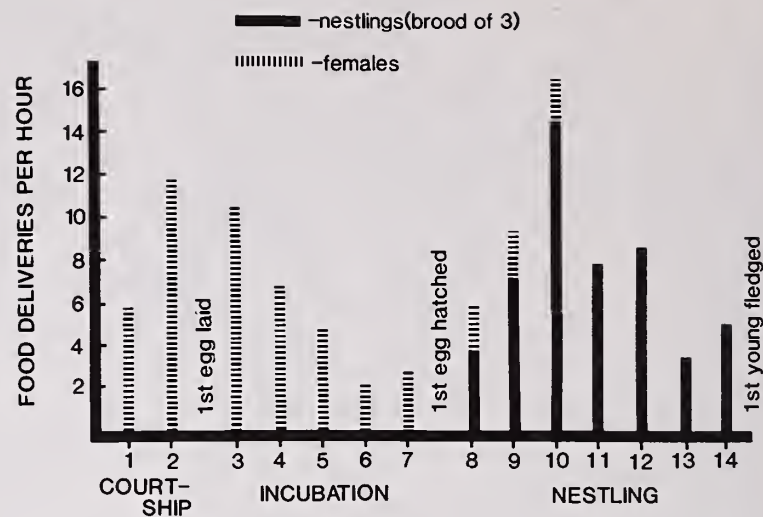

Figure 3.--Food delivery rates by males to females during courtship and to nests during incubation and nestling stages for 14 pairs of flammulated owls. Rate during the nestling stage represents the feeding of a brood of three young plus the female during the first 12 days and thereafter just the brood (see text). Mean observation period was 1.6 hr ($s = 0.90$, range = 0.5-3.9, $n = 61$), and all observation periods were between 20:30-03:00 hr MDT. Data are presented in 4-night periods, except for the last period in the incubation and nestling stages, which include 5 nights.

in deliveries probably reflects the decreasing growth rate of the young.

Adult owls ceased all activity during periods of snow or rain. For example, a severe thunderstorm at 22:00 hr on 25 June 1982 caused male A24 to cease foraging and seek shelter in a densely crowned ponderosa pine. As the storm intensified, the male changed trees three times, apparently seeking better shelter. Inclement weather also caused fledglings to become inactive. During 5 consecutive nights (25-29 July) of rain, the adults in A10 fed the owlets infrequently and only during periods of light rain, despite the frequent food-begging of the young. The fledglings perched near the ground on rocks, logs, and stumps during the rain.

Changes in Body Mass During Nesting

Body mass of adult females varied considerably through the nesting cycle (table 1). Female mass peaked just before egg laying. Female A10-82 was 96.0 g five nights prior to laying her third egg--39.0 g heavier than two nights prior to the fledging of her brood. During capture attempts on the night before egg-laying, females flew with difficulty and, after several flushes, ended up perched low to or on the ground. Females gradually lost weight after egg-laying. Female A11-83 was 68.0 g the night after her eggs hatched, 7.0 g less than she weighed 13 nights prior to laying. Mean mass of 16 adult females during the nestling stage was

Table 1.--Body mass of adult flammulated owls in four stages of the nesting cycle. Body mass of owls weighed more than once in a stage were averaged.

Stage	Males			Females		
	$\bar{x}(n)$	SD	Range	$\bar{x}(n)$	SD	Range
Prelaying				81.7(3)	12.42	74.0-96.0
Incubation	56.7(9)	3.42	53.0-62.0	78.3(4)	7.92	76.5-85.5
Nestling	53.2(15)	2.09	49.5-56.5	63.3(16)	4.45	56.0-70.5
Fledgling	55.8(3)	7.07	50.0-60.0	58.2(2)	6.72	53.5-63.0
Total season	54.7(27)	3.28	49.5-62.0	65.6(25)	10.85	53.5-96.0

63.3 g, a decrease from a mean of 78.3 g for four females during the incubation stage ($t = 5.17$, $df = 18$, $p < 0.05$).

Body mass of males fluctuated relatively little through the cycle (Table 1). The mean mass of nine males during incubation was 56.7 g. After hatching, the mean mass of 15 males was 53.2 g ($t = 3.13$, $df = 22$, $p < 0.05$). One male (A4-83) was 56.0 g three nights prior to hatching; 58.5 g three nights prior to fledging; and 60.0 g eleven nights after his young fledged. Two nights after his brood subgroup achieved independence, the male had dropped to 56.5 g. In mid-September (24 days post-fledging), he still was 56.5 g. However, on 6 October, the male was 67.0 g--a gain of 10.5 g during the previous 3 weeks. The male, radio-tagged, left the study tract on the night of 12 October.

Loss of weight by females after hatching to a low during the molt in September was similar to weight changes of nesting female long-eared owls in the Netherlands (Wijnandts 1984). Weight decrease of male flammulated owls, however, was not as great as the 12% decrease among male long-eared owls during nesting.

Owlets were first weighed 6-10 days after hatch (fig. 4). Mean mass of 11 nestlings was 61.3 g during the 5 days prior to fledging. In the 5 days following fledging, mass decreased to a mean of 54.6 g and ranged from 38.0 to 68.0 g. Some weight loss may have resulted from the increased activity associated with free flight, but most is attributable to decreased feeding during inclement weather that occurred at the time of fledging each year. For example, one owlet was 48.0 g 6 days prior to fledging, 44.0 g 2 days after fledging (26 July), and 38.0 g 5 days after fledging (29 July). Two siblings of this owlet also lost weight during this period--one was 56.0 g at fledging and 48.0 g 6 nights after fledging, and the other 51.0 g 5 nights before fledging and 50.0 g 5 nights after fledging. Weather on these 5 nights consisted of late afternoon or evening thundershowers followed by late night tree drip and fog. These and other owlets gained weight through the next 10 days, when, after independence, they again lost weight.

Predation and Mortality

There was no evidence of predation on adults or nestlings during the study. However, many old nesting cavities in quaking aspen on the study tract had been broken open by black bears (*Ursus americanus*). Predation on a flammulated owl nest in Colorado, by either a bobcat (*Lynx rufus*) or black bear, was reported by Richmond et al. (1980).

Three radio-tagged fledglings in our study were killed by predators within 6 days after fledging. Two were killed by *Accipiter* sp. and the third by an unknown mammal. Only one adult death was noted. A female (A11) was begging for food approximately 300 m west of her nest on 2 August 1983, 2 nights after her young fledged

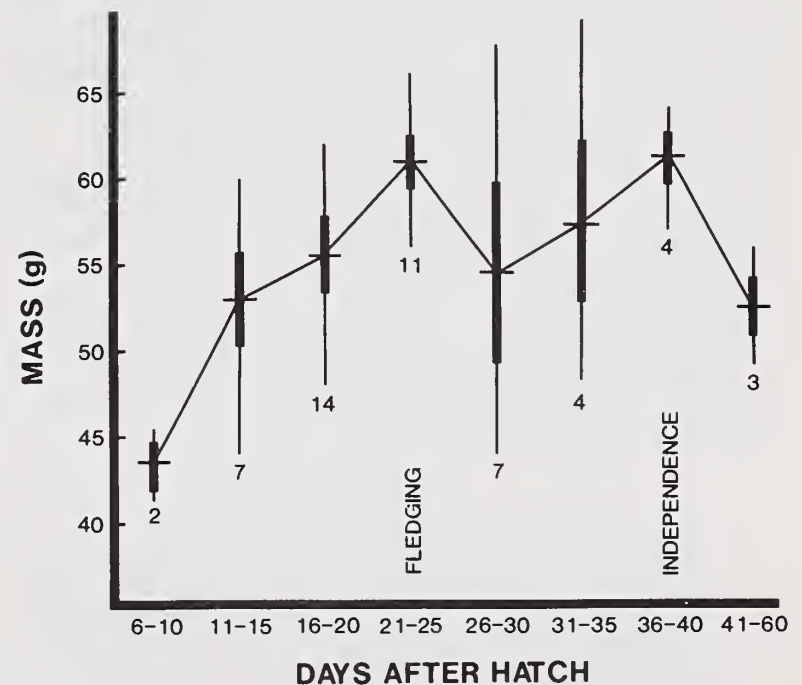

Figure 4.--Changes in body mass of owlets from 6-10 days after hatching. Horizontal bars are mean weights, thick vertical bars are 1 standard deviation around means, and vertical lines are ranges. Numbers below bars are number of owlets weighed during period.

and 1 or 2 nights after one of the fledglings was killed. Two males, one probably her mate, appeared to be feeding her, but she also captured several moths. She weighed 60 g and was well into the molt of her primaries. We attached a transmitter, and on 3, 4, and 5 August, she was observed on day-roosts. However, she was found dead 2 km from her nest on 8 August, and the emaciated carcass weighed 40.0 g. We had not observed other females begging for food after their broods had fledged.

Molt

Although all owls were examined for molt with each capture, only 5 adults were captured while molting. The molt of one male was assessed four times (4 and 19 August, 13 September, and 6 October) and once each for two other males (23 July and 18 September). Two females were assessed once each (18 July and 2 August). These assessments indicated that molt of the primaries in males and females is sequential (1 through 10), beginning during the second or third week of July and, at least for males, is completed by the end of September. Molt of the secondaries began in late September for one male, and there was no apparent order to the loss of secondaries. Tail molt in both males and females began with the central rectrices in early August and appeared to be centrifugal (Mayr and Mayr 1954). However, because only a few rectrices had been lost by October in birds assessed, the tail molt may be partial in this species (see Forsman 1981). We saw no evidence among owls observed or captured that molt of the rectrices was simultaneous (contra Bloom 1983).

Owlets were sparsely covered by white natal down after hatching. Within 10 days after hatch, a soft gray and horizontally banded juvenal plumage began to replace the natal down. The juvenal plumage was nearly completed at fledging, and the remiges of the owlets were about three-fifths and the rectrices about one-half developed. Both remiges and rectrices reached full development between 20 and 25 days after fledging. Replacement of the juvenal plumage began around the eyes several days after fledging and progressed slowly through the end of August. When owlets left our study area in late August, they retained some juvenal plumage on their backs and lower undersides.

DISCUSSION

Flammulated owls delivered prey to the nest at a greater rate during the first hr after dark and irregularly thereafter whenever food demands at nests were high. Males minimized travel time by foraging in IFAs close to the nest during these periods. Foraging in distant areas between periods of high demands may (1) reserve food in near patches, (2) reduce the attraction of predators to the nest, (3) facilitate territorial defense, or (4) allow more varied prey to be captured (Brooke 1981, Tinbergen 1981, Kacelnik 1984). Even though foraging in distant

patches increased the travel time, the effect was minimal because distant foraging occurred when food demands were low. It is interesting that the flammulated owl does not deliver more than a single food item per foraging trip. For birds feeding on prey whose mass seldom exceeds 0.5% of their mass, the high feeding rate at nests is not surprising. Furthermore, because the male is the sole provider of food through much of the nesting cycle, it is not surprising that most nests were contained within an IFA.

Linkhart et al. (in review) report that returning flammulated owls settled in stands of old-growth (> 200 yr) ponderosa pine--Douglas-fir and avoided other overstory types. Furthermore, after settling, the owls significantly preferred to forage in old-growth pine--fir patches and avoided young (< 100 yr), denser stands of Douglas-fir mixed with blue spruce. Other studies of this owl (e.g., Marshall 1939, 1957; Johnson and Russell 1962; Cannings et al. 1978; Bull and Anderson 1978; Winter 1974; Marcot and Hill 1980; Goggins 1986) associated the bird with mature trees of one of the yellow pines [Subsection Ponderosae (Laud.)] (Critchfield and Little 1966) mixed with other conifers or hardwoods.

The reasons for this association likely involves both food and habitat. First, the owl is an obligate cavity-nester, and older forests typically have an abundance of snags and live trees with suitable cavities. Second, old yellow pines typically form open stands with extensive grass or shrub understories (Moir 1966, Franklin and Dryness 1969). The understories provide a substrate for feeding and resting arthropods, and drop-pouncing to this substrate was frequently used by the owls during late summer (this study, Goggins 1986). Third, because widely spaced trees allow for greater movement of air, and therefore, faster drying and warming (Sukachev and Dylis 1964), moisture (within-canopy drip) from rains evaporate faster in open-canopied forests. As a result, the activity of arthropods--and foraging by the owls--would resume sooner in open forests after a rain. Fourth, although the abundances of noctuids and other arthropods, and the extent to which they are limited to pine-fir forests are unknown, many are host-plant specific and tend to be limited to specific habitats (Munroe 1979). Also, there are up to 4-times as many lepidopteran species associated with ponderosa pine or Douglas-fir than with other common western conifers (Furniss and Carolin 1977). Before the role of food in the owl's choice of habitat can be assessed, however, the composition, abundance, and activity periods of arthropods in the western forest types must be determined. Finally, at least 3 foraging tactics (hawk-gleaning, hover-gleaning, and hawking) require large, open crowns, and space between crowns. The interior portions of the crowns of large yellow pines and associated conifers (e.g., Douglas-fir) are open, exposing limbs and trunks that provide the owls with

perches and access to areas where arthropods rest. The openness of these stands also provides space between trees for hawking and gleaning insects. That the unique structure of older ponderosa and jeffrey pine (*P. jeffreyi*) forests in the north of the owl's range also occurs in similar yellow pine forests in their winter range (Mexico and Central America) suggests that the owl's foraging repertoire could be fine-tuned to this structure and, perhaps, to associated arthropods.

ACKNOWLEDGEMENTS

We thank Judy Jo Jeanson for help in the field. J. Schmid, R. Stevens, and D. C. Ferguson helped with the identification of the lepidoptera and other arthropods. B. Cade, G. Crouch, R. King, and R. Ryder critically reviewed the manuscript.

LITERATURE CITED

- Balda, R. P. 1977. The relationship of secondary cavity nesters to snag densities in western coniferous forests. Wildlife Habitat Technical Bulletin No. 1, USDA Forest Service, 37 pp.
- Balda, R. P., B. C. McKnight, and C. D. Johnson. 1975. Flammulated owl migration in the southwestern United States. *Wilson Bulletin* 87:520-523.
- Bent, A. C. 1938. Life histories of North American birds of prey. Part 2. U.S. National Museum Bulletin No. 170, 466 pp.
- Bloom, P. H. 1983. Notes on the distribution and biology of the flammulated owl in California. *Western Birds* 14:49-52.
- Brooke, M. L. 1981. How an adult wheatear (*Oenanthe oenanthe*) uses its territory when feeding its nestlings. *Journal of Animal Ecology* 50:686-696.
- Bull, E. L., and R. G. Anderson. 1978. Notes on flammulated owls in northeastern Oregon. *Murrelet* 59:26-27.
- Cannings, R. J. 1982. A flammulated owl nests in a nest box. *Murrelet* 63:66-68.
- Cannings, R. J., S. R. Cannings, J. M. Cannings, and G. P. Sirk. 1978. Successful breeding of the flammulated owl in British Columbia. *Murrelet* 59:74-75.
- Critchfield, W. B., and E. L. Little, Jr. 1966. Geographic distribution of the pines of the world. USDA Forest Service, Miscellaneous Publication 991. 97 p.
- Earhart, C. M., and N. K. Johnson. 1970. Size dimorphism and food habits of North American owls. *Condor* 72:251-264.
- Forsman, E. D. 1981. Molt of the spotted owl. *Auk* 98:735-742.
- Franklin, J. F., and C. T. Dryness. 1969. Vegetation of Washington and Oregon. USDA Forest Service, Research Paper PNW-80. 216 p.
- Franzreb, K. E., and R. D. Ohmart. 1978. The effects of timber harvesting on breeding birds in a mixed coniferous forest. *Condor* 80:431-441.
- Furniss, R. L., and V. M. Carolin. 1977. Western forest insects. 654 p. USDA Forest Service, Pacific Northwest Forest and Range Experiment Station, Miscellaneous Publication No. 1339.
- Gary, H. L., and M. J. Morris. 1980. Construction of wooden boxes for cavity-nesting birds. USDA Forest Service, Rocky Mountain Forest and Range Experiment Station, Research Note RM-381, 7 p.
- Goggins, R. 1986. Habitat use by flammulated owls in northeastern Oregon. Unpublished M.S. Thesis, Oregon State University, Corvallis, Oregon. 54 p.
- Hasenyager, R. N., J. C. Pederson, and A. W. Hagen. 1979. Flammulated owl nesting in a squirrel box. *Western Birds* 10:224.
- Hayward, G. 1986. Activity pattern of a pair of nesting flammulated owls (*Otus flammeolus*) in Idaho. *Northwest Science* 60:141-144.
- Huey, L. M. 1932. Two noteworthy records for California. *Auk* 49:107.
- Johnson, N. K., and W. C. Russell. 1962. Distribution data on certain owls in the western Great Basin. *Condor* 64:513-514.
- Kacelnik, A. 1984. Central place foraging in starlings (*Sturnus vulgaris*). I. Patch residence time. *Journal of Animal Ecology* 53:283-299.
- Linkhart, B. D., and R. T. Reynolds. 1987. Brood division and postnesting behavior in flammulated owls. *Wilson Bulletin* 99:240-243.
- Marcot, B. G., and R. Hill. 1980. Flammulated owls in northwestern California. *Western Birds* 11:141-149.
- Marshall, J. T., Jr. 1939. Territorial behavior of the flammulated screech owl. *Condor* 41:71-78.
- Marshall, J. T., Jr. 1957. Birds of the pine-oak woodland of southern Arizona and adjacent Mexico. *Pacific Coast Avifauna* 32:1-125.
- Mayr, E., and M. Mayr. 1954. The tail molt of small owls. *Auk* 71:172-178.
- Moir, W. H. 1966. The influence of ponderosa pine on herbaceous vegetation. *Ecology* 47:1045-1048.
- Munroe, E. 1979. Lepidoptera. In *Canada and Its Insect Fauna*. Memoirs of the Entomological Society of Canada, No. 108. Ed., H. V. Danks. The Entomological Society of Canada, Ottawa, Canada.
- Phillips, A. R. 1942. Notes on the migration of the elf and flammulated screech owls. *Wilson Bulletin* 54:132-137.
- Phillips, A. R., J. Marshall, Jr., and G. Monson. 1964. *The birds of Arizona*. University of Arizona Press, Tucson, 212 pp.
- Reynolds, R. T., and B. D. Linkhart. 1984. Methods and materials for capturing and monitoring flammulated owls. *Great Basin Naturalist* 44:49-51.
- Reynolds, R. T., and B. D. Linkhart. 1987. Fidelity to territory and mate in flammulated owls. *Symposium on the Biology*

- and Conservation of Northern Forest Owls, Winnipeg, Manitoba, Canada, February 3-7.
- Reynolds, R. T., B. D. Linkhart, and J. J. Jeanson. 1985. Characteristics of snags and trees containing cavities in a Colorado conifer forest. USDA Forest Service, Rocky Mountain Forest and Range Experiment Station, Research Note RM-455, 6 pp.
- Richmond, M. L., L. R. DeWeese, and R. E. Pillmore. 1980. Brief observations on the breeding biology of the flammulated owl in Colorado. *Western Birds* 11:35-46.
- Ross, A. 1969. Ecological aspects of the food habits of insectivorous screech owls. *Proceedings of Western Foundation of Vertebrate Zoology* 1:301-344.
- Sukachev, V., and N. Dylis. 1964. *Fundamentals of forest biogeocoenology*. Oliver and Boyd, London. 672 p.
- Sutton, G. M., and T. D. Burleigh. 1940. Birds of Las Vigas, Vera Cruz. *Auk* 57:234-243.
- Tinbergen, J. M. 1981. Foraging decisions in starlings (*Sturnis vulgaris* L.). *Ardea* 69:1-67.
- Webb, B. 1982. Distribution and nesting requirements of montane forest owls in Colorado. Part III: flammulated owl (*Otus flammeolus*). *Colorado Field Ornithologist Journal* 16:76-81.
- Wiens, J. A. 1969. An approach to the study of ecological relationships among grassland birds. *Ornithological Monographs* 8.
- Wijnandts, H. 1984. Ecological energetics of the long-eared owl (*Asio otus*). *Ardea* 72:1-92.
- Winter, J. 1971. Some critical notes on finding and seeing the flammulated owl. *Birding* 3:205-209.
- Winter, J. 1974. The distribution of the flammulated owl in California. *Western Birds* 5:25-44.

Distribution, Habitat Selection, and Densities of Flammulated Owls in British Columbia¹

R. Richard Howle and Ralph Ritcey²

Abstract.--Prior to 1980, there were only six records of Flammulated Owl for British Columbia. Literature records and field surveys were used to determine distribution and densities within preferred habitat. Birds appear restricted to older growth Douglas Fir forests between 375 m and 1250 m elevation in the southern Rocky Mountain Trench, Okanagan and South Thompson valleys. Densities varied from .03-1.6 singing males per 40 hectares but distribution was not contiguous.

INTRODUCTION

The Flammulated Owl (*Otus flammeolus*) is distributed from Guatemala north through forests of the western cordillera to southern British Columbia (Bent 1938). Distribution and ecology of this insectivorous cavity-nester remained virtually unknown in this province during the first seventy-five years after the owl was discovered here in 1902. The bird is assumed to be migratory and was considered to be a rare summer resident of the dry interior forests (Guiget 1960). Density estimates for singing males elsewhere in North America range from 1-5 per 40 ha (Marshall 1939, Winter 1974, Balda 1977, Franzreb and Ohmart 1978).

South of British Columbia, Flammulated Owls are typically associated with the ponderosa pine (*Pinus ponderosa*) belt from its lower admixture with oak (*Quercus* sp.) to the upper limits where the pine mixes with Douglas fir (*Pseudotsuga menziesii*), true firs (*Abies* sp.), Larch (*Larix* sp.) or incense cedars (*Libocedrus* sp.) (Marshall 1939, 1957, Phillips et al. 1964, Marcot and Hill 1980, Johnson and Russell 1962, Bull and Anderson 1978, Reynolds and Linkhart 1984). In Colorado, owls show a preference to forage in old-growth ponderosa pine-Douglas fir stands (Linkhart et al. in review) but they have been recorded in trembling aspen (*Populus tremuloides*) (Webb 1982) and second growth pine (Winter 1974). Searches for nests have been very limited (Bull and Anderson 1978, Reynolds and Linkhart 1984, Goggans 1986).

The lack of knowledge about Flammulated Owls in British Columbia was cause for concern due to their presumed preference for dry belt forests and dependence upon cavities for nests. The dry interior pine and fir forests are intensively managed for timber production in British Columbia and a little-known secretive owl species could suffer severe reductions in numbers that would remain undetected.

We accumulated information about owl records throughout British Columbia and conducted surveys near Kamloops in order to determine the habitat preferences for Flammulated Owls in the province. Estimates of singing male densities were made for some areas and distributional limits are discussed. Here we report our findings based upon limited surveys.

Fig. 1 Kamloops Study Area

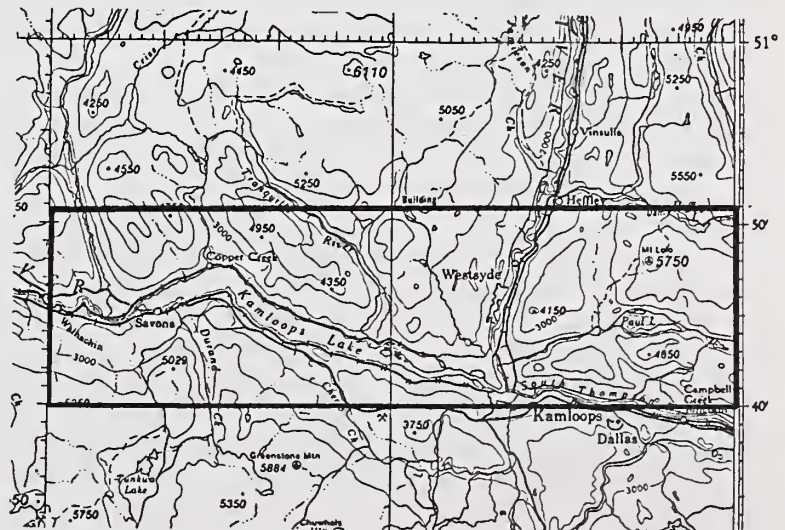

¹ Paper presented at the symposium, Biology and Conservation of Northern Forest Owls, Feb. 3-7, 1987, Winnipeg, Manitoba. USDA Forest Service General Technical Report RM-142.

² Howle is with the Parks and Outdoor Recreation Division and Ritcey is with the Wildlife Branch, Ministry of Environment and Parks, Kamloops, British Columbia.

STUDY AREA

Surveys were conducted along the South Thompson River drainage within an area approximately 70 km long and 20 km wide near Kamloops, British Columbia (Fig. 1). The area is an incised valley within the intermontane Thompson Plateau where maximum elevations approximate 2000 metres. Elevations within surveyed areas ranged from 350–1300 m. The forests in the study area consisted of ponderosa pine at lower elevations and mixed Douglas fir – ponderosa pine at middle elevations and south-facing slopes. Above 850 m, Douglas fir was dominant and ponderosa pine occurred as a seral species after fires and persisted as a veteran subdominant on drier, south-facing slopes. Trembling aspen occurred as a seral species on wetter ecosystems. At the highest elevation, Douglas fir maintained its dominance but lodgepole pine (*Pinus contorta*) occurred as a seral or fire climax species on drier sites. Selective logging had occurred extensively throughout the study area for at least 100 years resulting in mixed age stands and variable tree densities. Old growth stands (200+ years) generally occurred only on sites unsuitable for timber harvesting. Elsewhere, stand age classes ranged from mature (100–200 years) to second growth (< 100 years). Within most age classes, selective harvesting had resulted in variable canopy closures and stand structures. Snags and cavity-bearing trees occurred in varying densities throughout the area. The forest understory depended upon stand history, canopy closure and topographic factors but generally consisted of mixtures of grasses, forbs and shrubs as described by various authors (Mitchell and Green 1981, Brayshaw 1965, Tisdale and Maclean 1957). Common species were bluebunch wheatgrass (*Agropyron spicatum*), pinegrass (*Calamagrostis rubescens*), birch-leaved spirea (*Spirea betulifolia*) and saskatoon (*Amelanchier alnifolia*). Terrain was moderately steep (25–75 per cent slope.). Annual precipitation averages 32–43 cm with annual maxima in May–June and December–January. The mean annual temperature is –4 to –6°C with a mean July temperature of approximately 16°C. (Mitchell and Green 1981). With increased elevation, precipitation increases and temperatures decrease in the study area. More frequent surveys were conducted on Wheeler Mountain within the Tranquille Provincial Forest. The forest type was predominantly Douglas fir with ponderosa pine occurring on some south-facing slopes. The area was selectively logged 20–30 years prior to the surveys but many old and mature trees still existed. Stand ages varied from 80–200+ years with complexity provided by second-growth firs. Thickets of regenerating firs were common as were openings up to 1 or 2 ha in size. The forest structure was generally open but quantitative measurements were not made.

METHODS

Literature records and information from observers were obtained for areas throughout British Columbia where Flammulated Owls had been observed. From 1979–1986, random site visits were made to locations near Kamloops where owls were expected or known to occur. Birds were located by listening for singing males or eliciting responses by playing tape recorded territorial songs during May, June and early July. From 1983–1985, 10 linear census routes were driven along roads penetrating forests within the ponderosa pine and Douglas fir forest belts. The routes were driven between 2200 and 0100 hours during May, June and early July and stops were made every 0.5 km. Routes varied from 3–10 km in length. At each stop the first three minutes were spent listening for singing birds. If none were heard, a tape recorded song was played in order to elicit responses. The locations of all birds were plotted as closely as possible on 1:50,000 scale topographic maps. Weather conditions were noted and generally, routes were not surveyed during rain or if wind noise was considered excessive.

Given the terrain, forest cover and other factors, it was assumed that the radius within which owls might be heard would not exceed 0.5 km. Across open grasslands under very quiet conditions, birds have been heard up to 0.75 km away but this was considered exceptional.

An approximation of the area in hectares surveyed aurally (soundscape) along each route was calculated using the formula:

$$100 [n(.78) - (n-1).24]$$

where n equals the number of stops per route. This overestimates the actual area censused due to the curvilinear nature of the outer boundaries of the soundscape. Density figures were converted to singing males per 40 ha. Habitat characteristics were derived from simple field observations and forest cover maps prepared by the British Columbia Ministry of Forests and Lands. Detailed field measurements of tree and stand characteristics were not made.

RESULTS

DISTRIBUTION

Literature evidence and surveys resulted in records for 104 Flammulated Owls between 1902 and 1986 (Table 1). This included 10 juvenile, recently-fledged or nestling birds. Three centres of abundance are shown in Figure 2: the Okanagan Valley, the South Thompson River Valley and the southern Rocky Mountain Trench. The most northerly records occurred near Kamloops at 50° 51' latitude and at Radium in the Rocky Mountain Trench at 50° 40' latitude. Near Kamloops birds were recorded

west to 120° 55' longitude and east to 119° 50'. In the Okanagan Valley, records were obtained for the Vernon, Kelowna, Penticton and Okanagan Falls area south to about 40° 15' latitude. The Okanagan Valley runs generally north-south such that all sightings were between 119° 15' and 119° 35' W longitude. In the Rocky Mountain Trench all records were from the Radium-Windermere area at 50° 40' N latitude. Throughout the province, owls were only recorded between 375 m and 1250 m in elevation. Records occurred from 4 May - 22 October but the latest that a live bird was seen was 14 September. The 22 October record was of a dead bird and was an estimate of time of death (Brooks 1909).

HABITAT SELECTION

Except for 3 occasions, all birds were found within the interior Douglas fir biogeoclimatic zone (Krajina 1969). Within the more intensely surveyed study area near Kamloops, birds were

Table 1.--Summary of Flammulated Owl Sightings in British Columbia 1902-1986.

Year	# Birds	General Location	Reference
1902	1	Penticton	Brooks, A. 1909
1935	1	Kamloops	Williams & Spencer, 1942
1947	1	Penticton	Cannings, S. (pers. comm.)
1962	1	Penticton	Atkinson, R. 1963
1975	1	Radium	¹ Van Tighem, K. 1977
1977	1	Windermere	B.C.P.M.
1977	4	Penticton	Cannings, R.J. et al. 1978
1978	2	Penticton	B.C.P.M.
1979	3	Penticton	B.C.P.M.
1979	2	Kamloops	B.C.P.M.
1979	2	Kamloops	Howie, R. (unpub. rep.)
1980	2	Okanagan Falls	B.C.P.M.
1980	4	Penticton	Cannings & Cannings 1982
1981	2	Penticton	Cannings & Cannings 1982
1981	5	Kamloops	Howie, R. (unpub. rep.)
1982	2	Kamloops	Howie, R. (unpub. rep.)
1983	11	Kamloops	Howie & Ritcey (unpub. rep.)
1983	2	Penticton	B.C.P.M.
1984	19	Kamloops	Howie & Ritcey (unpub. rep.)
1984	2	Pritchard	Bowling, J. (pers. comm.)
1984	3	Kelowna	Bowling, J. (pers. comm.)
1984	1	Vaseaux Lake	Cannings, R.J. (pers. comm.)
1985	21	Kamloops	Howie & Ritcey (unpub. rep.)
1985	1	Vaseaux Lake	Cannings, R.J. (pers. comm.)
1986	7	Kamloops	Howie, R. (unpub. rep.)
1986	5	Penticton	Cannings, S. (pers. comm.)

¹ British Columbia Provincial Museum Sight Records File.

Fig. 2-- Flammulated Owl Centres of Abundance

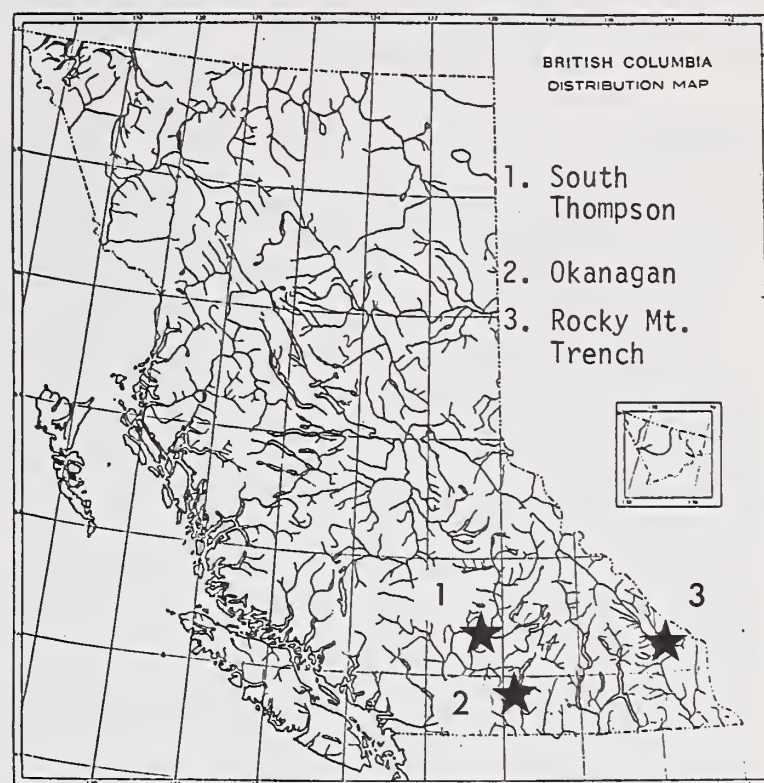

confined to a drier subzone referred to as the "very dry submontane interior Douglas fir (IDFa) (Mitchell and Green 1981). Observations of the habitat elsewhere in the province where Flammulated Owls have been recorded confirm a strong association with this forest type. No birds were found in the ponderosa pine belt. Near Kamloops where 70 per cent of all sightings have occurred, some owls were found in old growth (200 + yr) Douglas fir with veteran ponderosa pines scattered throughout the area. One site was moderately steep (60 per cent), south facing and had been selectively harvested more than 50 years prior to our survey. Most owls were found in mature-old (100-200 yr) growth stands of Douglas fir that had been selectively harvested 20-30 years prior to our surveys. On the intensively surveyed Wheeler Mountain (50° 46' N, 120° 28' W) stand age classifications ranged from 80-240 years with most of the area in the 140-250 year class. Harvesting had removed many large stems but veteran Douglas fir and ponderosa pine were common. The forest structure was generally open with canopy closure ranging from 35-65 per cent except in thickets of regenerating Douglas fir. At least two canopy layers were present in areas where owls were found with older firs and pines forming the upper layers and second-growth firs forming the lower layers. A poorly-developed shrub layer was generally present and was dominated by Saskatoon. Depending upon site moisture and canopy characteristics, the herb layer was well-developed and consisted of Pinegrass or Bluebunch Wheatgrass and various sub-dominants. Birch-leaved Spirea occurred on many sites.

No owls were found in clearcut areas nor areas where the general age class of the forest was less than 80 years. One bird was found in

mature timber adjacent to a regenerating clearcut and one bird was calling from a copse of Trembling Aspen in grassland but older Douglas fir forest was present within 250 m.

Densities

Survey results from 10 census routes near Kamloops are given in Table 2. Considering the soundscape censused along the entire length of the routes, densities of singing males ranged from .03 - .5 per 40 ha on surveys where birds were heard. On all except the Wheeler Mountain route, the number of males heard per survey ranged from 0-3. Distribution of males along the Wheeler Mountain route was not consistent between years and appears to be clumped (Table 3). Considering only the soundscape censused between the first and last stops where owls were heard, density estimates were higher than for the entire route and varied from 0.4 - 0.7 singing males per 40 ha. (Table 4). On two sites on Wheeler Mountain, more intensive ground surveys located 3 and 4 singing males within two 100 ha areas or 1.2 - 1.6 males per 40 ha. On a third site on Mount Fleet, 2 males were singing within an 80 hectare area or 1 bird per 40 ha.

DISCUSSION

The Flammulated Owl occurs in two disjunct areas of British Columbia. The major portion of the range is within the dry belt forest of the interior plateau north to 50° 51' latitude. Two records from the Radium Hot Springs area suggest that the Rocky Mountain Trench north to about 50° 40' latitude is the other major area of occurrence in the province. The two areas are about 350 km apart and separated by the Columbia Mountains which reach over 3000 m in elevation and are covered with dense, moist forests at lower elevations. Flammulated Owls have never been recorded from these forest types. Both major areas of the province are northern extensions of dry forest types found in Washington and Montana with no physiographic barriers to the natural expansion of owls from populations in these two states immediately south of B.C.

Table 2.--Survey Route Density Estimates.

Route	Date	Singing Males	Males per 40 ha
Wheeler Mountain	83.06.16	8	.30
Upper Dewdrop	83.06.23	1	.05
Opax Mountain	83.06.29	1	.06
Wheeler Mountain	84.06.25	8	.30
Sabiston Lake	84.06.27	0	.00
Timber Lake	84.06.29	0	.00
Eagle Hill	84.07.09	3	.00
Wheeler Mountain	85.06.20	13	.50
Wheeler Mountain	85.07.05	11	.40
Indian Garden	85.07.09	1	.03

Table 3.--Singing Males Wheeler Mountain Route.

Stop	June 16 1983	June 25 1984	June 20 1985	July 5 1985
1				1
2		1	1	1
3				
4	1			
5			1	
6	2	1	1	
7		1	2	
8	1	1	1	1
9	1	1	2	1
10	1		2	1
11	2	2	2	1
12			1	
13		1	1	
14				
15			1	1
16			2	1
17			1	1
18				1
19				1
20				
Totals	8	8	17	11
			(4 repeats)	(2 repeats)

Within the central portion of the range, all records have occurred along the sides of two major intermontane valleys: the Okanagan valley and the South Thompson River valley. Smaller drainages feeding into these larger basins also contain owls. Virtually all of the records have occurred within the distributional limits of the very dry submontane interior Douglas fir forest (IDFa). This open forest occurs as a belt around the sides of major valleys and averages between 850 and 1130 metres in elevation (Mitchell and Green 1981). It lies immediately above the ponderosa pine belt but pine does extend upwards as a seral species after fire or as a codominant with Douglas fir on south-facing slopes. Various authors have recognized the association of Flammulated Owls with ponderosa pine (Winter 1971, Bull and Anderson 1978, Goggans 1986) and a strong preference for foraging in old-growth ponderosa pine - Douglas fir forests (Reynolds and Linkhart 1986). In

Table 4.--Density Estimates Wheeler Mountain Route.

Date	Singing Males	Soundscape	Males Per 40 ha
June 16, 1983	8	450 ha	0.7
June 25, 1984	8	650 ha	0.5
June 20, 1985	13	850 ha	0.6
July 5, 1985	11	1000 ha	0.4

British Columbia, the association with mature-old growth Douglas fir is more clear than the affiliation with ponderosa pine forests. While pine may occur on some sites, it is never a dominant species and usually occurs as isolated veterans well above their normal altitudinal limits. On north-facing slopes, pine is absent but owls are present. Regardless of the presence of pine, the open nature of the fir forests coupled with natural or artificial openings created by logging probably resembles the physical structure of preferred forests in the southern portion of the owl's range. Distribution of the bird in British Columbia is most likely restricted to the IDFa forest belt and equivalent forest types in the Rocky Mountain Trench.

Surveys and random observations near Kamloops confirm a preference for forest in excess of 100 years of age and the highest density of owls occurred in age classes of 140-200+ years with many veteran trees. Selective logging has been a common practice throughout the dry forests of the interior and has resulted in a complex forest structure. The amount of large stems removed varies greatly, depends upon the faller's preference and may reach 80 per cent. The results have been stands with multi-layered canopies and thickets of regenerating firs suffering from crowding and growth restrictions. Owls appear to be restricted to areas with multi-layered canopies and an abundance of large well-spaced trees interspersed with grassy openings up to 2 ha in size. Cavity-bearing snags were moderately common on sites where owls were found. Seven nests were found within the commonly used habitat type. Regenerating thickets were used for roosting but no studies have been done in British Columbia which quantify habitat preference as have been done elsewhere. (Goggans 1986, Reynolds et al. 1987). Random field observations suggest that owls in the fir belt of this province are utilizing the physical characteristics of the forests in similar ways to those noted by Goggans (1986) and Reynolds et al. (1986).

Historical data on Flammulated Owl populations in this province are lacking so it is impossible to say whether the selective cutting practices have resulted in a change in numbers. Several studies have noted a decline in populations following timber harvesting (Marshall, 1957, Phillips et al. 1964, Franzreb and Ohmart 1978). The surveys we conducted were not specifically designed to estimate populations or densities, but some crude estimates were made in order to create a perspective for future studies. On Wheeler Mountain, selectively cut areas appeared to have singing male densities as high as 1.6 males per 40 ha. Transect surveys may have underestimated the real numbers of birds present by as much as 50 per cent, but this may have been due in part to erroneous assumptions made in the surveying procedure. The estimated soundscape surveyed from each stop on the transects was a circle with a radius of 0.5 km. This may be a generous assumption so that density estimates are likely low. Regardless, densities are in the

lower end of the scale reported for this species elsewhere within its range. They compare favorably with estimates of 0.72 singing males per 40 ha in northeastern Oregon (Goggans 1986) and roughly 0.8 per 40 ha in Colorado (Reynolds, Linkhart and Ryder 1986, in press). Densities varied within the total area of Wheeler Mountain. Our transects did not result in a census of the entire mountain, much of which is felt to be suitable habitat. Along transect routes, densities were only 0.4 - 0.7 males per 40 ha. The lowest density was determined from the July 5 survey during which only 1 male was singing voluntarily and was perhaps unmated. The other ten birds were found by playing tape recorded songs. The number of birds responding represents an unknown proportion of the real population but 13 birds were found along the same route two weeks earlier in the same year. The results along other routes should also be considered preliminary. Attempts were made to census only during optimal conditions, but wind noise and light rain were negative factors on some routes. It is felt that the lower densities along routes other than Wheeler Mountain resulted from extensive areas of marginal or unsuitable habitat being surveyed. Once we entered the optimal habitat type, Flammulated Owls were found. The patchy distribution of the habitat is likely responsible for the clumped distribution of owls and may be the reason that birds have been considered loosely colonial (Winters 1974).

Further studies are necessary in order to more clearly delineate the range of this little-known owl in British Columbia. Basic ecological relationships remain poorly understood but it is clear that the bird occupies older forests in areas that are very important to the lumber industry. As currently practised, selective harvesting techniques may enable us to afford this species protection and still manage forests for timber production. The alternative may result in the loss of a unique member of Canada's avifaunal component.

LITERATURE CITED

- Atkinson, R.N. 1963. Flammulated Owl nesting in British Columbia. *Can. Field Nat.* 77: 59-60.
- Balda, R.P. 1977. The relationship of secondary cavity nesters to snag densities in western coniferous forests. *Wildl. Hab. Tech. Bull.* No. 1 Forest Service, U.S.D.A. 37 pp.
- Bent, A.C. 1938. Life histories of North American birds of prey. Part 2. *U.S. Nat. Mus. Bull.* No. 170, 466 pp.
- Brayshaw, T.C. 1965. The dry forest of southern British Columbia. *Ecology of Western North America.* Vol. 1: 65-75.
- British Columbia Provincial Museum Sight Records File. B.C. Provincial Museum, 601 Belleville St., Victoria, British Columbia.
- Brooks, A. 1909. Some notes on the birds of the Okanagan, British Columbia. *Auk.* 26: 60-63.

- Bull, E. and R.G. Anderson, 1978. Notes on Flammulated Owls in northeastern Oregon. *Murrelet* 59: 26-28.
- Cannings, R.J. 1974. A record of the Flammulated Owl in Canada. *Can. Field Nat.* 88: 234-235.
- Cannings, R.J., S.R. Cannings, J.M. Cannings and G.P. Sirk. 1978. Successful breeding of the Flammulated Owl in British Columbia. *Murrelet* 59: 74-75.
- Cannings, R.J. and S.R. Cannings. 1982. A Flammulated Owl nests in a box. *Murrelet* 63: 66-68.
- Franzreb, K.E. and R.D. Ohmart. 1978. The effects of timber harvesting on breeding birds in a mixed coniferous forest. *Condor* 80: 431-441.
- Goggans, R. 1986. Habitat use by Flammulated Owls in northeastern Oregon. Unpublished Masters Thesis, Oregon State University. 54 pp.
- Guiget, C. 1960. The birds of British Columbia. Pt. 7. The Owls. *British Columbia Prov. Mus. Handbook No. 18.*
- Johnson, N.K. and W.C. Russell. 1962. Distributional data on certain owls in the western Great Basin. *Condor* 64: 513-514.
- Krajina, V. 1969. Ecology of forest trees in British Columbia. Vol. 2 No. 1. Dept. of Botany, University of British Columbia.
- Linkhart, B.D., R.T. Reynolds and R.A. Ryder. (In Review). Size, spacing and utilization of breeding ranges by Flammulated Owls. *J. Wildlife Management.*
- Marcot, B.G. and R. Hill. 1980. Flammulated Owls in northwestern California. *Western Birds* 11: 141-149.
- Marshall, J.T. 1939. Territorial behavior of the Flammulated Screech Owl. *Condor* 41: 71-78.
- Marshall, J.T. Jr. 1957. Birds of the pine-oak woodland in southern Arizona and adjacent Mexico. *Pac. Coast Avif.* 32: 1-125.
- Mitchell, W.R. and R.E. Green. 1981. Identification and interpretation of ecosystems of the western Kamloops forest region. Vol. 1. Prov. of British Columbia, Ministry of Forests, Victoria.
- Phillips, A., J. Marshall and G. Monson. 1964. *The birds of Arizona.* Univ. of Arizona Press, Tucson.
- Reynolds, R.T. and B.D. Linkhart. 1984. Methods and Materials for capturing and monitoring Flammulated Owls. *Great Basin Naturalist* 44(1): 49-51.
- Reynolds, R.T. and B.D. Linkhart and R.A. Ryder. 1987. Home ranges of Flammulated Owls. *Symposium on the Evolution and Ecology of Northern Forest Owls.* Winnipeg, Manitoba.
- Tisdale, E.W. and A. Maclean. 1957. The Douglas fir zone of southern British Columbia. *Ecological Monographs* 27: 247-266.
- Van Tighem, K. 1977. The avifauna of Kootenay National Park. Unpublished Report. Parks Canada.
- Webb, B. 1982. Distribution and nesting requirements of montane forest owls in Colorado. Part III: Flammulated Owl (*Otus flammeolus*). *Colorado Field Ornith. Journal* 16: 76-81.
- Winter, J. 1974. The distribution of the Flammulated Owl in California. *Western Birds* 5: 25-44.

Censusing Screech Owls in Southern Connecticut¹

Dwight G. Smith,² Arnold Devine,³ and Dan Walsh⁴

Abstract.--Eastern screech owls (*Otus asio*) were censused in southern Connecticut using playback of tape recorded song. Response frequency and type of response varied seasonally; rates were lowest during the breeding season and highest in fall and winter. Extreme temperatures, certain types and intensity of background noise, and wind decreased response frequency. Tests with radio-marked owls confirmed accommodation of some owls to repeated song playback. Comparison with population estimates obtained using a combination of playback and foot searches suggest that song playback provides estimates within 5-20% of actual screech owl populations.

INTRODUCTION

The eastern screech owl (*Otus asio*) is a small, cryptic owl that ranges from the foothills of the Rocky Mountains to the east coast and northward into adjacent portions of southern Canada. Throughout much of its range it is often the most common bird of prey, occupying a wide variety of habitats in which trees or other structures provide cavities for roosting and nesting. It is also among the most adaptable of raptors to man-modified habitats and may be found in suburban woodlots and the cemeteries, parks and other open spaces of towns and cities.

Despite its relative abundance in suitable habitats this screech owl is rarely noticed because of its nocturnal activity patterns and habit of roosting in concealed locations during daylight hours. Consequently, comparatively little is known of its behavior and population ecology.

Results of a 10 year census of Screech Owls in suburban-rural environments of southern Connecticut using playback of tape recorded song are presented herein. We investigated screech owl response to song playback and census variables such as month,

seasonal activity, moon phase and selected weather conditions. We also noted color phase when possible, and describe perch site selection and behavior of responding owls.

We compared estimates of screech owl abundance determined from playback censuses with estimates based on results of foot searches for roost sites and signs such as pellet deposits, feathers and kill sites.

REVIEW OF LITERATURE

The use of song for acoustic communication in birds has been detailed by Kroodsma et al. (1982) and more specifically for mating and spacing behavior by Catchpole (1982). Eastern screech owls use song for territorial establishment, defense and mating (Bent 1938; and others).

The use of playback of tape recorded song as an avian census technique has been reviewed by Johnson et al. (1981) and Marion et al. (1981) and as a census technique for raptors by Fuller et al. (1981). These authors emphasized the effectiveness of playback in sampling nocturnal or otherwise secretive birds and advocated wider use of this technique to census or locate birds which may respond to vocalizations. Johnson et al. (1981) used song playback to census western screech owls (*Otus kennicotti*) in riparian habitats of southern Arizona; they discovered the highest documented breeding density of screech owls in North America. Other censuses of screech owls using song playback included a fall survey in Michigan (Nowicki 1974), a spring survey in Kansas (Cink 1975) and a 16 week summer survey in Kentucky (Allaire and Landrum 1975).

¹Paper presented at the symposium, Biology and Conservation of Northern Forest Owls, Feb. 3-7, 1987, Winnipeg, Manitoba. USDA Forest Service General Technical Report RM-142.

²Dwight G. Smith is Professor of Biology, Southern Connecticut State University, New Haven, Conn.

³Arnold Devine is Environmental Analyst, Hazardous Waste Disposal Unit, Department of Environmental Protection, Hartford, Conn.

⁴Daniel T. Walsh is a zoology doctoral student at Brigham Young University, Provo, Utah.

Springer (1978) compared response to playback with a visual count of roosts and nests to estimate populations of the great horned owl (Bubo virginianus) in Ohio while McGarigal and Frazer (1984, 1985) evaluated response and habitat use of barred owls (Strix varia) in Virginia. In the last 2 decades playback has also been employed to count owls, mainly screech owls and great horned owls during the annual Christmas bird counts.

STUDY AREAS

Routes for censusing screech owls by song playback were located in the towns of Bethany, Branford, Hamden, Oxford, Orange, East Haven, and Watertown, all in New Haven and Litchfield Counties, Connecticut. Census route details are presented in table 1.

We conducted foot searches for pellets deposited beneath cavities and owls sunning at cavity entrances in Bethany, Oxford and Woodbridge in southern Connecticut and near Elizabethtown, Lancaster County in Pennsylvania. The Pennsylvania study area was described by Smith (1981, 1986). Screech owl accommodation to song playback was tested in New Canaan, Orange and Bethany, Connecticut, during fall and winter months of 1981, 1982 and 1985.

Excepting East Haven, the towns in which the surveys were conducted are suburban-rural habitats with population densities ranging from a low of 173 persons km² in Oxford to a moderate density residential population of 2400 persons km² in Hamden.

Table 1.--Descriptions of eastern screech owl census routes in southern Connecticut.

Route	Date Started	Date Stopped	Census Interval ¹	Census ² Pattern	Route Length (km)	No. Stations	No. Times Censused	Total Length (km) ³	Total ³ Stations	Observers ⁴
Bethany I	11/11/76	06/23/79	Biweekly	Grid	22.9	24	1	645	645	DGS, DS, MS
Bethany II	12/20/76	05/29/79	Biweekly	Grid	22.4	20	26	472	502	DGS, DS, MS
Bethany III	12/29/79	12/16/81	Biweekly	Grid	20.0	13	34	680	382	DW
Bethany IV	12/27/79	11/07/81	Biweekly	Grid	17.6	13	34	598	442	DW
Bethany V	01/06/82	07/21/85	Monthly	Grid	22.9	24	41	803	850	DGS, MS
Bethany VI	01/12/82	07/06/85	Monthly	Grid	22.4	20	41	781	737	DGS, MS
Branford	10/12/79	09/10/80	Irregular	Linear	11.2	6	16	154	87	DW
Hamden	01/12/80	11/09/81	Irregular	Grid	12.0	9	11	132	98	DW
Orange	02/07/80	02/15/82	Irregular	Linear	8-28.0	9-29	26	493	401	MD, DGS
Oxford I	10/06/76	10/23/78	Biweekly	Grid	28.0	19	43	1202	710	AD, DG
Oxford II	12/28/76	10/05/78	Biweekly	Grid	23.0	15	33	697	456	AD, DG
Watertown	12/27/80	10/02/81	Irregular	Grid	20.3	14	8	156	110	DW
Totals ⁵	--	--	--	--	236.3	188	344	6813	5534	--

¹Census intervals were biweekly, monthly or irregular.

²Census patterns were square grid, circular grid or linear.

³All route census data combined.

⁴Observers: AD, Arnold Devine; MD, Mark Drummond; DG, Debbie Gendron; DGS, Dwight Smith; MS, Maureen Smith; DS, Douglas Spencer; DW, Dan Walsh.

⁵Totals with Orange census route average of 12.8 km and 11 stations.

The towns lack major industries although a number of small industries are located in several. Habitats of the towns in which the censuses were conducted included wooded areas (38% to 72% of total area of each census route), farmland (0 to 13%), old fields, meadows, pastures (6% to 39.5%), wetland and aquatic habitats (2% to 14%) and residential (6% to 37%).

Historically, most of the study area was farmland and most of the woodlands were clear-cut for farming or for the lumber industry. Although farming is still practiced to some extent in the census areas most of the farmland was abandoned or sold and consequently some of the habitat is in successional stages, principally old field, although much has reverted to woodland. Woodlands in these areas are predominately deciduous and composed of maples (Acer), oaks (Quercus), hickories (Carya), American beech (Fagus grandifolia), white ash (Fraxinus americana) and tuliptree (Liriodendron tulipifera) with understory components of birches (Betula species) and dogwood (Cornus florida). A variety of ornamental trees and shrubs occur in the residential areas.

METHODS

Censusing by Playback of Tape Recorded Song

Census routes in Bethany and Oxford formed a grid pattern with stations located 0.5-1.8 km apart. In other towns, census routes were linear and were selected to ensure adequate coverage of the mix of residential and natural habitats present.

Stations were spaced approximately 0.7-1.2 km apart, based on a preliminary study conducted by AD in Oxford and Bethany from October through May, 1975-76, and estimates of the size of home ranges of 2 screech owls observed near Elizabethtown, Pennsylvania, by DGS. Results of this study and the sizes of screech owl home ranges determined using radiotelemetry (Smith and Gilbert 1984) in New Canaan, Orange and Bethany, Connecticut, support this spacing.

Exact location of each census station was influenced by its accessibility, proximity to woodlots or ornamentals, houses and parked vehicles and knowledge of previous owl responses.

The pairs of routes in Oxford and Bethany were censused alternately, so that each route was censused biweekly. This time interval was selected on the basis of preliminary studies conducted by DGS and AD in 1975 and 1976 to test accommodation of owls to song playback as a function of time interval between sequential surveys. Censusing of AD and DGS routes was performed in a random starting sequence on alternate weeks to determine if time of night influenced owl response. Censusing of all routes began within 0.5-1.5 hr after sunset.

At each station song playback, included a sequence of whinny and warble songs obtained from the Peterson Field Guide to Bird Songs. Tests conducted along census routes revealed that omnidirectional broadcast of song playback was audible (to us) for a minimum radius of 0.8 km.

Each station was censused for 7-8 min to elicit a vocal or visual response. This consisted of a 1 min listening interval, 5 min song playback interspersed by silent periods of approximately 15 sec and a 2 min listening interval. When an owl responded, the playback was continued for an additional 2 min to elicit response from a second owl. For each response we recorded the number of owls responding, direction of each owl, time interval from first playback to the first visual or audible response and type of response. Owls were illuminated with a flashlight when possible to observe color phase, perch site and behavior.

Variables recorded at the time of censusing at each station were time (EST), sky condition, types and intensities of background noise, moon phase, temperature and wind. Time was recorded as time of first playback. Sky condition was estimated as percent overcast, moon phase was recorded as quarter, half, three-quarter, full and no moon. The sources of background noises were recorded and their intensity estimated on a scale of 1-10 on Bethany census routes conducted by DW and DGS. Temperature was recorded to the nearest 0.5 C. Wind velocity was estimated using the terrestrial application of the Beaufort scale.

Foot and Vehicle Surveys

Foot searches were conducted in 2 isolated woodlots in Pennsylvania, each averaging about 2.59 km² in size and in randomly selected 2.59

km² portions of study areas in Bethany and Oxford. The Pennsylvania surveys were conducted by DGS. Separate surveys in Bethany were conducted by DW, AD and DGS and in Oxford by AD.

In each area we located all tree cavities and other likely roosting and nesting areas such as small, dense conifer stands. These were uniformly searched for signs of screech owls. In Pennsylvania, all cavities were checked by ascents.

Accommodation Tests

To test for accommodation of screech owls to playback of tape recorded song 4 groups, each comprised of 4 screech owls were captured and fitted with radiotransmitters. Owls were captured in roosts, nest boxes and using bal-chatri traps in New Canaan, Bethany and Orange, Connecticut. One owl from each group was censused using song playback at 1 day intervals, 1 at 3 day intervals, 1 at 7 day intervals and 1 at 14 day intervals for 3 months. Censusing of 2 groups was conducted from late September through late December and of 2 groups from November through January. Preliminary studies by DGS and AD had suggested that these were months of uniformly high screech owl response. Prior to each playback, the presence of the screech owl was confirmed by radiotelemetry.

Data Analysis

We used SPSS-X routines (SPSS 1983) for data organization and analysis. Principal components analysis (PCA) was used to search for the variable or combinations of variables which accounted for the highest amount of the total observed variation. Five climate variables (precipitation, cloud cover, wind, sky condition, and temperature), 3 temporal measures (month, time of night and sequence), noise and moon phase were included in the initial correlation matrix. Data entry for the PCA was a subsample obtained by a random sort. The PCA was varimax-rotated to improve interpretation axes.

RESULTS

Playback of Taped Song Surveys

Response Frequency

Screech owl responses were obtained on 37.7% of all calling attempts (2199 responses of 5534 attempts) with all stations on all census routes combined (table 2). At least 1 response was heard at 89.9% of all (169 or 188) calling stations, all routes combined, but the response frequency at each station varied from 3% to 78.8% and averaged 18.2%, suggesting that not all stations were located in screech owl habitat or home range. Thus 11 stations (5.9% of total stations) had a response frequency of less than 5% during the survey while 52 stations (27.7%) had an overall response frequency of over 50%; with the latter station response frequency suggesting the presence of a resident individual or pair.

Table 2.--Summary of eastern screech owl response rates:
by month and census route for southern Connecticut.

Month	Bethany 76-85			Bethany 80-81			Combined ¹			Orange			Oxford			Totals		
	#	Response		#	Response		#	Response		#	Response		#	Response		#	Response	
	Sta	#	%	Sta	#	%	Sta	#	%	Sta	#	%	Sta	#	%	Sta	#	%
Jan	158	84	53.2	102	24	23.5	46	9	19.6	44	16	36.4	46	14	30.6	396	147	37.1
Feb	230	119	51.7	76	19	25.0	49	14	28.5	39	14	35.9	66	26	39.2	460	192	41.7
Mar	404	173	42.8	50	7	14.0	18	6	33.3	61	3	4.9	101	29	28.7	634	218	34.4
Apr	197	51	25.8	46	5	10.8	17	4	23.5	63	6	8.7	93	19	20.2	416	85	20.4
May	168	44	26.1	99	10	10.1	23	2	8.7	40	6	14.8	116	35	30.2	446	97	21.7
Jun	99	50	50.5	118	32	27.1	26	1	3.8	8	3	37.5	98	59	40.2	349	145	41.5
Jul	43	18	42.0	69	8	20.5	26	7	26.9	12	1	8.3	86	36	41.2	236	70	29.7
Aug	132	61	46.2	82	21	25.6	11	7	63.6	---	---	----	100	52	52.0	325	141	43.4
Sep	309	138	44.7	90	26	28.9	14	3	21.4	22	8	36.4	59	27	46.0	494	200	40.5
Oct	228	92	40.4	96	24	25.0	23	13	56.5	46	18	39.1	183	98	53.4	576	245	42.5
Nov	400	253	63.2	55	8	14.5	37	12	32.4	40	21	52.5	136	86	63.4	668	380	56.9
Dec	366	196	53.6	36	18	50.0	5	0	0.0	26	18	69.2	101	47	46.5	534	279	52.2
Totals or Average	2734	1279	46.8	919	202	22.0	295	78	26.4	401	114	28.4	1185	528	44.6	5534	2199	39.7

¹Branford, Hamden, Watertown.

Monthly response frequency followed a seasonal cycle, varying from a low of 20.4% in April (results of all surveys combined) to a high of 56.9% in November. On all census routes the lowest response rates were in April and May while the highest response rates were during the winter months, especially November and December. The period of decreased response frequency occurred during the spring months from late February through May, and to a lesser extent during early summer. This period corresponds with screech owl breeding activities, including egg deposition and incubation, and raising of young in this region, suggesting that screech owls may be secretive during at least part of the nesting season. Allaire and Landrum (1975) also noted a decreased response frequency of nesting screech owls in Kentucky. The increase in response frequency noted during July and August is undoubtedly due to the activities of juvenile screech owls, which have augmented the local populations and are behaviorally often quite responsive during the post-fledging dependency period.

Approximately 14% of the responses were by screech owl pairs. Responses by pairs were recorded from October through June, most frequently in December and March, and were usually more intense and of longer duration than responses by individuals. Slightly less than 4% of responses were by 3 or 4 screech owls. Movements and perches selected by these owls suggested territorial limits, especially when several responses were obtained over a period of 1 or 2 months.

The time interval between the first playback of song and the first screech owl response also varied seasonally. Shortest response times occurred during fall and winter, with monthly averages ranging from 2.34 min in February to 3.05 min in December (table 3). Average response time increased during the spring and summer, with the longest recorded in April, May and June. This seasonal variation occurs synchronously with the

observed variation in overall response frequency and again suggests that screech owls are comparatively reluctant to answer playback of tape recorded song during the nesting season.

Screech Owl Response Forms

Screech owls responded to playback of tape recorded song with a variety of songs and other vocalizations. A few individuals also responded non-vocally; they were observed flying into the immediate area near the broadcasting tape recorder but did not sing or otherwise vocalize.

The most common screech owl response songs were the whinny and warble described by Bent (1938). Individuals in this area showed the greatest variation in the whinny song, which ranged from high to low in pitch and volume and to a much lesser extent varied in duration and number of times repeated. The warble was comparatively uniform in delivery by individuals and consisted of a series of hollow whistles of 1 pitch, separated initially, but merging in a tremolo. Frequently, screech owls responded with a whinny and subsequently switched to the warble song but the reverse also was occasionally noted. Other vocalizations consisted of "screams," "screeches" and bill clacking. The "scream" was occasionally given by juvenile owls and was a shrieking series of mouse-like squeaks, often given during flight. It was typically, but not always, followed by a series of soft whinnies, also given during flight.

Both whinny and warble songs were heard throughout the year, although a seasonal variation in frequency of each was evident (figure 1). During the period after the young had fledged, from June to August, both songs were heard with approximately equal frequency along with a variety of screams, screeches and other vocalizations made by fledged juveniles. Frequency of whinny song increased in August and essentially replaced the warble song throughout the fall and winter months,

Table 3.--Monthly summary of eastern screech owl response time and type, data from all census routes combined.

Month	Response Time (min)			Response Type										N Responses
	\bar{X}	SD	Range	Whinny		Warble		Both		Other		Visual ¹		
				N	%	N	%	N	%	N	%	N	%	
Jan	2.80	1.16	0.1-8.0	74	60.7	11	9.0	35	28.7	0	---	2	1.6	122
Feb	2.34	1.13	0.4-7.1	48	43.6	38	34.4	24	21.8	0	---	0	---	110
Mar	2.84	1.39	0.1-7.5	36	37.9	42	44.2	16	16.8	0	---	1	1.1	95
Apr	3.69	1.56	1.2-8.0	34	24.3	79	56.4	27	19.3	0	---	0	---	140
May	3.65	1.73	0.5-7.4	26	26.0	41	41.0	33	33.0	0	---	0	---	100
Jun	3.17	1.66	0.5-8.0	71	39.7	60	33.5	36	20.1	12	6.7	0	---	179
Jul	3.03	1.33	0.3-7.0	61	40.7	49	32.7	34	22.7	5	3.3	1	0.7	150
Aug	3.09	1.37	0.5-7.0	82	58.6	16	11.4	40	28.6	1	0.7	1	0.7	140
Sep	2.91	1.63	0.5-8.0	109	67.7	18	11.2	33	20.5	1	0.6	0	---	161
Oct	2.67	1.15	0.1-6.0	127	68.3	9	4.8	46	24.7	1	0.5	3	0.6	186
Nov	2.92	1.43	0.3-7.0	70	70.0	4	4.0	24	24.4	0	---	2	2.0	100
Dec	3.05	1.90	0.3-7.0	78	86.7	0	---	8	8.9	0	---	4	4.4	90
Totals	3.01	0.38	0.1-8.0	816	51.9	367	23.3	356	22.6	20	1.3	14	0.9	1573

¹Owls observed that flew into area but did not vocally respond to playback.

suggesting that the whinny song is used extensively for territorial establishment and defense. In late January, frequency of warble song increased and for a brief 2-6 week period both songs were heard with equal frequency on most census routes. From late February through May the warble song displaced the whinny as the most common response

song. The initial vocal responses by a screech owl pair usually consisted of the same song (whinny or warble) although occasionally either the male or female, or both, switched to the other song.

The observed seasonal difference in use of whinny and warble songs is significant when subjected to a chi-square test of a 2 x 12 contingency table (chi-square = 292.37, df = 11, P < 0.01). We further tested seasonality of response song by subdividing the contingency table by grouping warble song during the nesting season months (March through May) compared to its frequency during the remainder of the year. The resulting 2 x 2 contingency table chi-square was again significant (chi-square = 121.96, df = 1, P < 0.01).

These results agree with earlier comments by Bent (1938) and Hough (1960) regarding the function of the 2 basic screech owl songs. These and other authors and naturalists have noted that the "mating" song (warble) begins in February and is used throughout the spring months, to be replaced by a "territorial" song (whinny) in late summer, fall and winter. Hough (1960) also noted that screech owls near Kripplebush, New York, had a brief silent period in January, but we did not observe this on any of our census routes.

About 0.9% (14 of a sample of 1573 records of response behavior) of the responding screech owls flew directly into the area near to where the tape recorder was broadcasting screech owl songs, but did not respond vocally. These non-vocal individuals were most frequently observed during fall and winter months, suggesting that they may have been young of the year owls without an established territory. However, the lack of a similar frequency of non-vocal individuals during the rest of the year may have been a function of the lack of foliage in fall and winter, which made them more easily observable.

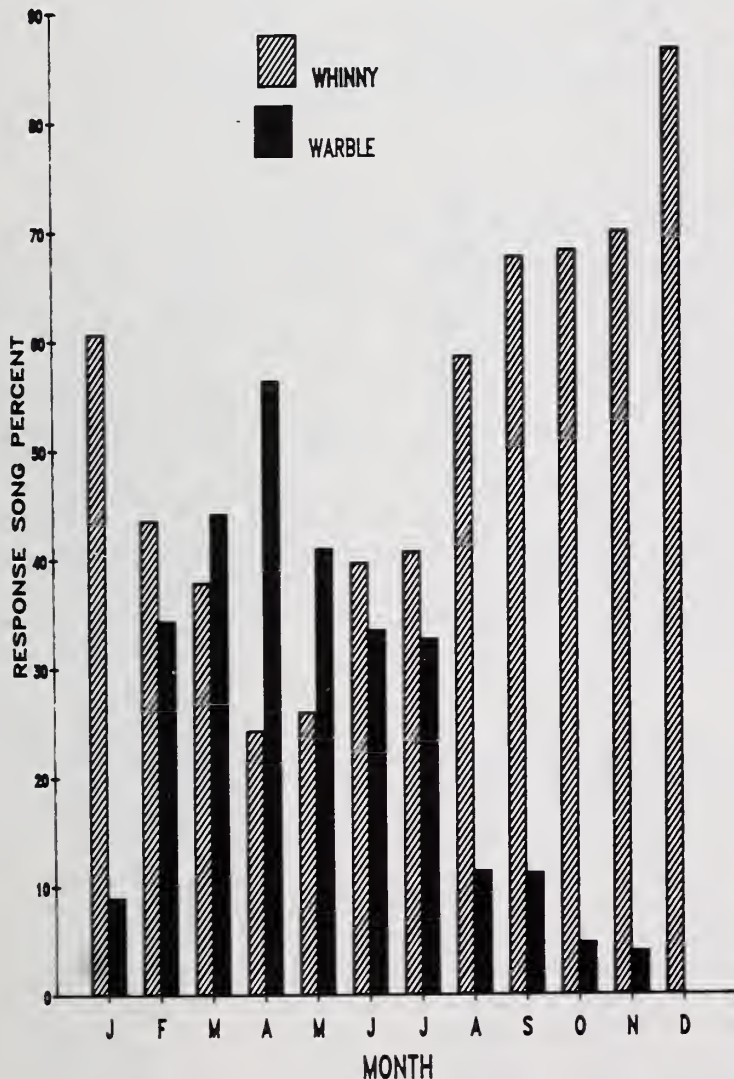

Figure 1.--Monthly frequency of whinny and warble song. Data from all census routes.

Color Phase

Color phase of a responding screech owl was determined when conditions permitted identification. Of 214 owls observed, 150 (70.1%) were gray-phased, 47 (21.9%) red-phased and 17 (7.9%) intermediate. The comparatively low number of intermediate owls actually observed may underestimate the frequency of this color phase in southern Connecticut because several variations of the intermediate color are difficult to differentiate from the gray-phase at night by a flashlight beam. Collectively, the intermediate owls showed a wide variation in color gradation from gray to red, although 3 were the rich "chocolate" or dark brown color.

These figures are approximately consistent with data reported by Owen (1963a, 1963b) who observed a declining frequency of red-phased screech owls northward in eastern North America. The reduced frequency of red-phased owls also agrees with research by Mosher and Henny (1976) who suggested that red-phased screech owls may suffer a higher winter mortality in northern locations due to their significantly higher metabolic requirements at low temperatures compared to gray-phased owls. Van Camp and Henny (1975) observed a higher mortality rate of red-phased screech owls during an especially harsh winter in northern Ohio.

Environmental Factors and Response Frequency

PCA of variables associated with screech owl response frequency results produced 4 factors with eigenvalues greater than 1.0 and collectively accounting for 63.5% of the total variation (table 4). The first factor had high positive loadings for month and sequence; and may be interpreted as an indication of the importance of temporal factors, especially the time of year. A high positive loading for temperature for this factor also would be anticipated, since temperature varies directly with season. The second factor had high positive loadings for precipitation and cloud cover and a high negative loading for wind. These 3 variables are interrelated since cloud cover is, of course, involved in precipitation and both may be accompanied by wind. Therefore we suggest that

this factor represented a climate component. The third factor had high loadings for noise, temperature and time. Noise levels caused by cars and other human activity, wind and insects often decreased during the later evening hours and this factor may, in fact, demonstrate that relationship. The fourth factor is not readily interpretable.

Partial correlations of census variables with screech owl response are presented in table 5. Significant correlations associated with screech owl response include month, sequence and wind. The correlation of response frequency with month reiterates the seasonal change in screech owl response frequency described previously. The relationship with sequence is especially important because it indicates some degree of accommodation by screech owls to playback of tape recorded song which must be considered when censusing of this owl will be conducted for an extended period of time. Wind negatively influenced screech owl response. Although our radiotelemetry studies indicated that screech owls did leave their roost sites regardless of wind conditions they may have decreased their foraging activity as wind velocity increased, perhaps because of inherent foraging difficulties. As a negative factor, wind is probably even more important than indicated by this

Table 4.--Factor matrix of variables associated with number of screech owl responses obtained during censusing.

	Factor 1	Factor 2	Factor 3	Factor 4
Month	.769	.005	-.107	.147
Temperature	.583	.276	.555	-.157
Precipitation	.059	.723	-.443	.064
Cloud Cover	.312	.711	-.110	-.023
Noise	.283	.284	.596	.197
Sequence	.788	-.118	.522	.397
Time	-.206	.309	.427	-.674
Wind	-.129	-.676	-.005	.530
Moon	.274	-.035	-.244	-.386
Variance %	19.4	16.0	15.5	12.6
Cum. Variance	19.4	35.4	50.9	63.5

Table 5.--Linear Correlation Coefficients (Lower Left) and Partial Correlation Coefficients (Upper Right) of Census Variables¹

	Response %	Month	Time	Sequence	Temp	Moon	Wind	Cloud	Noise	Precip
Response %	--	-.1601*	-.0567	.1183	.0650	-.1013	-.5518**	.0153	-.0843*	.0747
Month	.3159**	--								
Time	-.0104	-.2531	--							
Sequence	-.2150**	.0689	-.0221	--						
Temp	.2114**	.0798	-.0719	-.0992	--					
Moon	.1137	.1135*	-.1426*	-.0233	.1557*	--				
Wind	-.3420**	-.1020	-.0065	-.0064	-.0288	-.0059	--			
Cloud	.0952	.1628**	.0049	.0132	.0703	-.0570	-.0077	--		
Noise	-.3117**	.0156	.1184	.1015	.2140*	-.1586	.3255**	-.0511	--	
Precip	.0174	.1990**	-.0039	-.0516	.0253	-.0594	-.1200*	.0780*	.3024*	--

¹Probability Levels: * P < 0.05; ** P < 0.01.

partial correlation; we occasionally terminated our surveys early on windy nights because of exceptionally poor response frequency. The lack of a significant correlation with moon phase is interesting; anecdotal accounts by Leon Kelso (pers. commun.) and others suggest that screech owls are especially active and responsive on full moon nights, but we have been unable to confirm this. Results of a separate study conducted by Pat Lynch (1982) with DGS concerning response of urban open space screech owls in southern Connecticut also failed to indicate a correlation between screech owl response frequency and moon phase.

The behavior of responding owls varied to some extent with weather conditions. On bright, clear nights with a three-quarter or full moon responding owls were generally reluctant to approach the speaker and their response duration was usually brief. In contrast, on dark, cloudy or foggy nights responding owls were more aggressive, approached the speaker and remained in the vicinity longer, frequently singing.

A semiquantitative treatment of the relationship between 9 sources of noise and response frequency is illustrated in figure 2. Several of the background noises most frequently recorded at census stations were seasonal; insect noise was recorded at almost every station during late spring, summer and early fall; while amphibian noise was usually recorded in spring. Aircraft and car noise was recorded at almost every station throughout the year: the study areas were bisected by several roads and located near several private and commercial airports.

Comparison of response frequency at "quiet" stations with "noisy" stations confirms that noise negatively affects response frequency and suggests that a variety of noises might act individually or in combination. There is no obvious difference in affect of man-caused noise such as voices, cars or airplanes and natural noise; this, however, is not unexpected since the census areas are located in suburban rural habitats and we may presume that resident screech owls are accustomed to such noises. Therefore, we are unable to determine noise related decrease in response frequency is due to disturbance factors, inability of the screech owl to hear the song playback, or our inability to hear the screech owl response.

Accommodation

The responsiveness of radiomarked owls to test accommodation varied directly as a function of the frequency of song playback surveys. Screech owls censused on 1 and 3 day intervals showed less than 15% overall response rate during the 3 month testing period with only 2 exceptions while owls censused at 14 day intervals showed the highest overall response rate throughout the censusing period (figure 3). In addition, we noted that most of the responses by screech owls censused at 1 and 3 day intervals occurred during the first 2 or 3 weeks of censusing, thereafter they seldom responded although radiotelemetry confirmed their presence

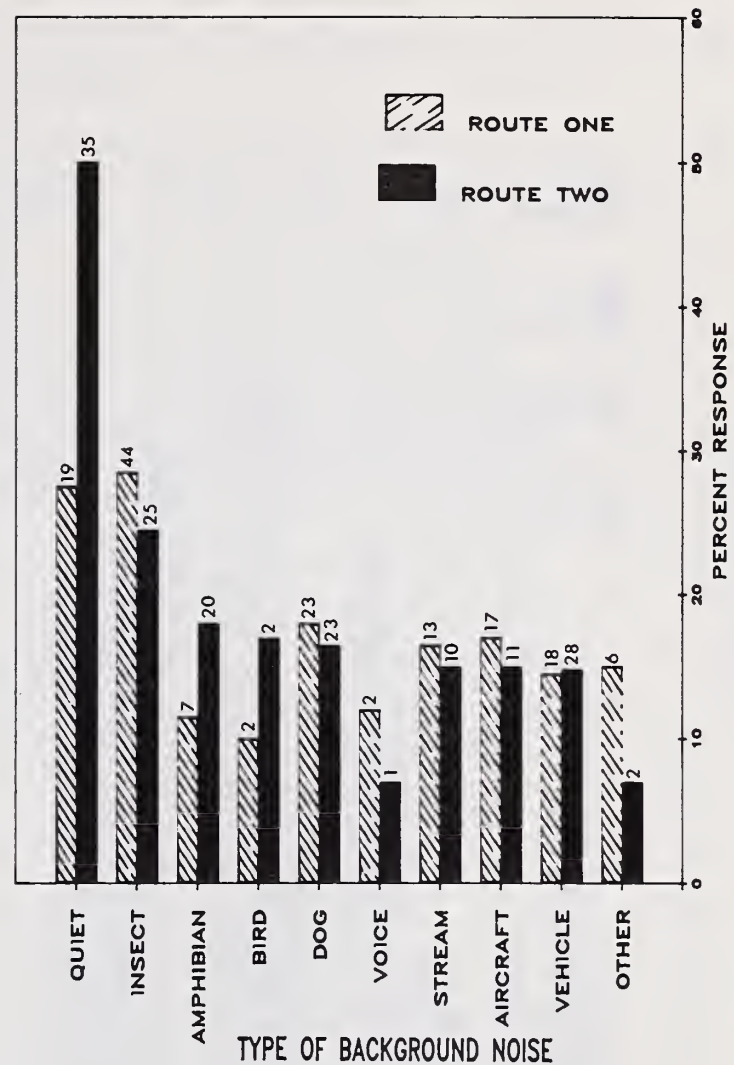

Figure 2.--Relationship between observed response frequency and types of background noise. Data from census conducted by DW. Numbers represent observed incidence of background noise.

within their home range. Conversely, owls censused at 7 and 14 day intervals showed a much greater uniformity of response during the test period. Smith (1979) found a similar decrease in barred owl response frequency when censused at daily intervals in late summer in northeastern Pennsylvania.

Perch Site Selection

Perch site selection by eastern screech owls responding to playback of tape recorded song was determined, when possible, on surveys conducted by DW and DGS (table 6). Totals for each category of information represent observations for that category and overall totals may therefore differ among categories.

No significant differences were detected in perch sites selected by red and gray-phased owls, when values are weighted for the differences in color phase sample sizes. Preston (1980) described differential perch site selection by color morphs of the red-tailed hawk (*Buteo jamaicensis*) and proposed that perch sites were selected to maximize concealment from potential prey. Color morphs of screech owls, however, lack distinct light and dark phases and this, plus their nocturnal activity patterns may negate the need for

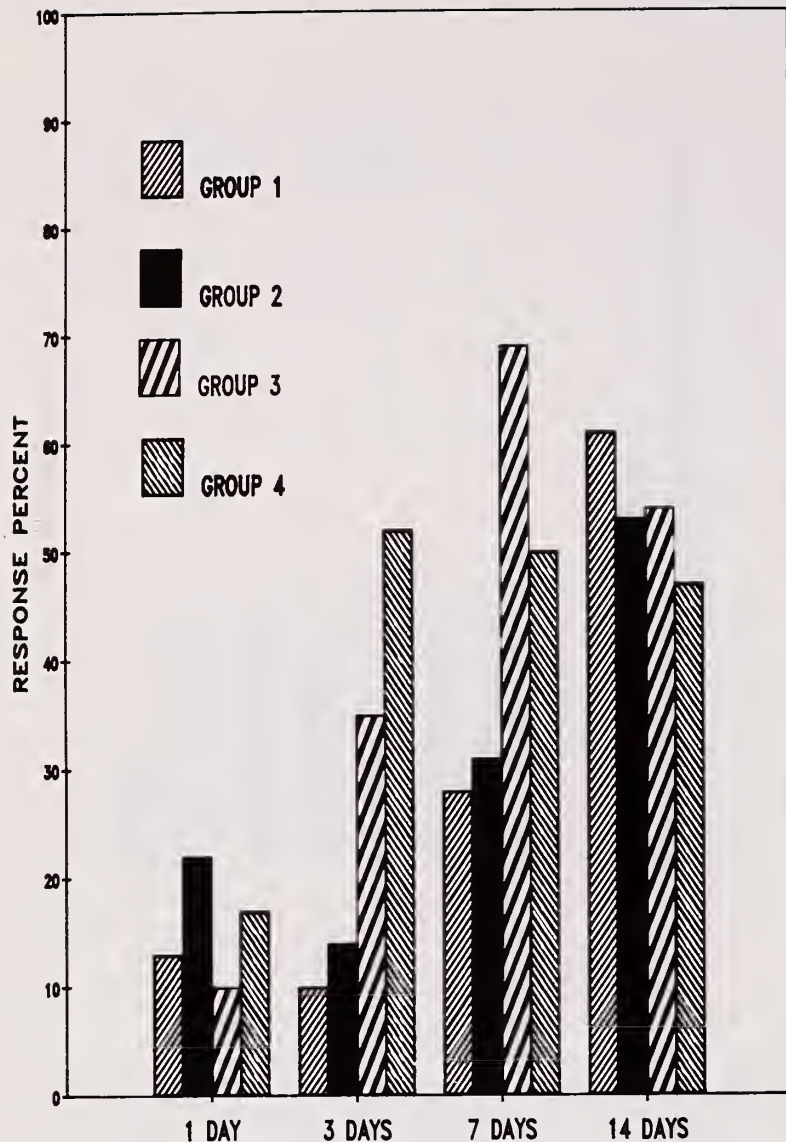

Figure 3.--Relationship between response frequency and censusing interval to test accommodation of eastern screech owls to playback of tape recorded song.

differential perch site selection by the red and gray-phased individuals. It should be noted however, that this applies only to screech owls responding to playback of tape recorded song and not owls actively foraging or roosting.

Perch heights of responding owls averaged 4.65 m and ranged from 1.5 to 11.0 m, although considerable variation was observed. Perch sites were mainly trees (92.1%) although telephone lines, poles, fence posts, concrete abutments and buildings were infrequently used. Almost 75.1% of trees in which screech owls perched had a dbh of 22.9 cm or smaller, reflecting a selection of saplings and relatively young trees. However, trees of this size commonly represented the most abundant component of woodland understory and ornamentals planted in yards.

Basically, responding owls chose perch sites which afforded both protection and concealment; they tended to avoid selection of isolated trees, high perches in mature trees with a relatively open canopy and very low perch sites. Thus the perch sites chosen provided good platforms for broadcast of response song while simultaneously offering maximum concealment from potential predators.

Other Responding Species

At least 13 other species responded to playback of eastern screech owl song, including 3 species of owls (table 7). Responses by other owls were heard mostly during winter and early spring months from October through March while responses by avian species other than owls were heard during spring and summer months. Great horned owls responded most frequently (14 of 62 recorded responses by species other than screech owls), especially during their period of territorial establishment and defense which occurs in this area from December through March. At least 1 great horned owl responded by flying to an overhead tree limb which had previously been the favorite response perch of a screech owl responding to DGS broadcast. The great horned owl sat quietly on the limb for several min during and after playback, then flew away. Subsequently, DGS did not obtain a screech owl response in this territory again for over a year, suggesting the possibility that at least some great horned owls will attempt to prey on singing screech owls.

American woodcocks were heard on censuses conducted separately by DGS, DW and AD during May and whip-poor-wills were heard during May and June. Woodcock migrate into southern Connecticut in late March and whip-poor-wills in early May: both species are vocally aggressive during the late spring and early summer months. Screech owl song most commonly elicited responses by a variety of passerines (32 of 62 responses), of which we were able to identify 6 species. Of these, mockingbirds (*Mimus polyglottos*) were the most responsive, especially during May and June. On 22 May 1978 a mockingbird was heard singing on AD arrival at a screech owl survey station prior to the use of playback. After playing the screech owl song the mockingbird subsequently imitated a crow (*Corvus brachyrosus*) call, and continued until he departed (Devine, 1982).

Population Estimates Using Song Playback

Estimates of screech owl population density are difficult to obtain because of inherent variables in response frequency caused by weather, seasonal variation in owl responsiveness and accommodation. We chose to estimate screech owl abundance during fall and early winter months, from October through January. The screech owl population density, augmented by addition of young of year, is highest at this time and both adults and yearlings are behaviorally most responsive to song playback.

We made several assumptions when determining screech owl density in the census areas including (1) census stations were spaced equidistant within the grid system, so that separate areas were censused by each station (2) stations with a total recorded screech owl response frequency of 50% or greater during the fall and winter survey were assumed to have resident owls or (3) stations with a response frequency of 35% or greater during every month were assumed to have resident owls.

Table 6.--Summary of perch sites used by responding eastern screech owls. Data from censuses conducted by DW and DGS. Percentages are in parenthesis.

Color Phase ¹	Height of Perch (m)				Type of Perch							
					Tree		Post		Line		Other ²	
	N	X	SD	Range	N	%	N	%	N	%	N	%
Gray	78	4.79	2.6	1.5-10.6	78	48.3	2	1.3	2	1.3	1	0.5
Red	34	4.12	2.9	1.4- 8.2	33	21.9	0	---	0	---	1	0.5
Unknown	39	5.03	3.1	1.9-11.0	33	21.9	3	2.0	1	0.5	2	1.3
Total	151	4.65			139	92.1	5	4.3	3	1.8	4	2.3

Color Phase ¹	Tree Size Class ³								Type of Limb					
	A		B		C		D		Horiz		Vertical		V-crotch	
	N	%	N	%	N	%	N	%	N	%	N	%	N	%
Gray	48	40.7	7	6.1	2	1.7	2	1.7	46	38.3	7	5.8	2	1.7
Red	6	5.2	9	7.8	9	7.8	1	0.8	25	20.8	3	2.5	10	8.3
Unknown	16	13.9	12	10.4	3	2.6	0	---	23	19.2	2	1.7	2	1.7
Total	70	60.9	28	24.3	14	12.1	3	2.6	94	78.3	12	10.0	14	11.7

Color Phase ¹	Tree Species													
	Red Maple		Sugar Maple		White Oak		Red Cedar		Birch sp.		Apple		Other ⁴	
	N	%	N	%	N	%	N	%	N	%	N	%	N	%
Gray	16	15.1	3	2.8	5	4.7	3	2.8	3	2.8	7	6.6	15	14.2
Red	8	7.5	3	2.8	1	0.9	2	1.9	1	0.9	1	0.9	9	8.5
Unknown	3	2.8	3	2.8	3	2.8	1	0.9	5	4.7	1	0.9	14	13.2

¹Intermediates included with red-phased owls.

²Other observed perches included telephone poles (2), top of van (1), car top (1).

³Tree size classes were: A = 3-9 cm; B = 10-20 cm; C = 21-33 cm, D = 33+ cm; diameters.

⁴Other species included Black Locust (1), Black Oak (1), Black Cherry (3), Witch Hazel (1), Red Pine (2), ornamental conifers (3), ornamental hedge (2).

Results of our population estimates for the 3 survey areas are presented in table 8. Density estimates on the study areas ranged from 1.41 owls/km² in Bethany to 0.63 owls/km² in Oxford. These estimates are considerably higher than reported in other studies of eastern screech owls. In Michigan, Nowicki (1974) recorded a screech owl population density of 0.88 owls/km², whereas Craighead and Craighead (1956), using foot searches, reported densities ranging from 0.24 owls/km² in 1941 to 0.38 owls/km² in 1947 and 1948. In northeastern Kansas, Cink (1975) determined a population density of 0.1-0.35 owls/km² by song playback. Nowicki (1974) and Cink (1975) suggested that there is a significant relationship between screech owl abundance and percentage of available habitat as woodland. Correlation of our density estimates with amount of woodland in each of the study areas was significant ($r = 0.788$, $P < 0.05$), thus providing additional evidence for this relationship.

The accuracy of estimates obtained by song playback censuses varied considerably when compared with estimates obtained by a combination of song playback and foot searches and with foot searches alone. Near Elizabethtown, song playback coupled with visual sightings indicated a density of 1.2 owls/km² in the isolated woodlots while census results were 1.09 owls/km², a difference of less than 10%. Foot searches alone revealed a density of 0.5 owls/km², a 59% difference. Comparative results

for Bethany, show similar discrepancies in accuracy of each of the 3 methods. In Oxford, AD determined a screech owl abundance of 1.54 owls/km², which was 58% higher than estimates determined on song playback census routes. Use of foot searches alone provided positive evidence of less than 0.45 owls/km² at Elizabethtown and 0.2 owls/km² in Bethany, both of very questionable percentage.

ABUNDANCE ESTIMATES BY LOCATING SCREECH OWLS AT CAVITY ENTRANCES

Craighead and Craighead (1956) estimated screech owl populations on their Michigan study area by observing individuals "sunning" at cavity entrances. While this method presumably works well in areas where woodlots are small, easily accessible and suitable roosting cavities readily located and monitored, it is very difficult to apply in southern Connecticut and other areas of woodland which offer a larger number of cavities.

We tested use of this method in southern Connecticut and near Elizabethtown, Pennsylvania by (1) observing the frequency of sunning by radio-transmitter equipped screech owls at different roosts and (2) monitoring individuals known to be using specific roost cavities to determine how frequently they were sunning at cavity entrances during daylight hours.

Table 7.--Responses to playback of taped song of eastern screech owls by other species. Data is from Bethany and Oxford census routes.

Species	Month										Total
	Jan	Feb	Mar	Apr	May	Jun	Aug	Oct	Dec		
Great Horned Owl (<u>Bubo virginianus</u>)	5 ¹	3	2				1	1	2	14	
Barred Owl (<u>Strix varia</u>)			1		2			1	1	5	
Saw-Whet Owl (<u>Aegolius acadicus</u>)		1 ²								1	
American Woodcock (<u>Philohela minor</u>)					6					6	
Mourning Dove (<u>Zenaida macroura</u>)						1				1	
Whip-poor-will (<u>Caprimilgus vociferus</u>)					1	2				3	
Mockingbird (<u>Mimis polyglottos</u>)					1 ³	5				6	
Catbird (<u>Dimetella carolinensis</u>)						1				1	
Black-Throated Green Warbler (<u>Dendroica virens</u>)						2				2	
Ovenbird (<u>Seiurus aurocapillus</u>)					1					1	
Cardinal (<u>Cardinalis cardinalis</u>)				1						1	
Field Sparrow (<u>Spizella pusilla</u>)					1					1	
Unidentified Anseriformes			1							1	
Unidentified Passeriformes		1	6	1	1	8	1	1		19	
Totals	5	5	10	2	13	19	2	3	3	62	

¹ Great Horned Owl response was visual.

² Saw-Whet Owl was observed at a census station.

³ Mockingbird imitated crow after playback of tape.

Of 4 radiotransmitter equipped screech owls for which we have 7 or more roost site records, a female monitored for approximately 14 months was observed sunning at 9 of 15 (60.0%) regularly used roost sites. Another, a male monitored for 4 months, was observed sunning at 3 of 7 (42.9%), while 2 monitored during February and March used

2 of 7 (28.6%) cavities for sunning, apparently regardless of weather conditions. Collectively, these records suggest that probably most or all screech owls do exhibit sunning behavior at suitable roost cavity entrances. However, they also suggest that not all roost sites may be used for sunning.

Table 8.--Comparison of screech owl population density estimates obtained by song playback surveys, combination surveys and on-foot surveys. Data from censuses conducted by DGS and AD.

Survey Area	Song Playback	Combination	On-Foot	%	%
	Owls/km ²	Owls/km ²	Owls/km ²	Diff. ¹	Woodland
Bethany	0.92	1.18	0.3	21.9	71.4
Elizabethtown	1.05	1.20	0.5	9.0	89.6
Oxford	0.63	1.54	---	40.9	71.5

¹Percent difference between density estimates obtained by song playback surveys and combination surveys presented.

Daylight sunning of screech owls appears to be a function of several variables, including disturbance levels near the roost site, weather conditions and individual behavior. Generally, screech owls sun or at least appear at roost site entrances more frequently during afternoon and early evening hours compared to morning hours (table 9). Almost all screech owls appeared at cavity entrances for at least a brief period during the evening hours after sunset but before total darkness.

Individuals sunning varied considerably in their tolerance of types and intensities of disturbance. Three were exceptionally tolerant; all had roost sites in large maples adjacent to busy roads and would sun at the cavity entrance even during periods of busy traffic. Of these, 1 was located about 6 m from a multi-family unit house. This individual was accustomed to and tolerant of a variety of activities on the sidewalk directly beneath the roost such as children playing, adults parking cars and walking up to the roost tree and dogs barking nearby. The other 2 owls, however, were tolerant only of moving cars and people jogging by below. If cars slowed or stopped in the immediate vicinity of the roost sites the owls would drop into the cavity. Most of the other individuals observed at roost site entrances were much less tolerant of human activity and would drop into the cavity as soon as we appeared or were heard. Again, tolerance appeared to be a function of the particular roost site selected to at least some extent. The previously noted transmitter-equipped female which was exceptionally tolerant while in the high roost cavity adjacent to the roadway was easily disturbed when occupying some other roost sites such as nest boxes and low snags and was never observed at a few sites.

We were unable to obtain reliable density estimates of screech owls using this technique, even in the relatively small study areas in which it was applied. In Elizabethtown, only 1 roost was discovered although the singing incidence of owls suggested a much higher local abundance. In southern Connecticut we located 15 of 250 (6%) of screech owl roost sites by observation of sunning owls. We were unable however, to locate roost sites of

owls which, on the basis of repeated playback surveys, were known to be within a specific area, quite possibly because of the need to check most cavities by foot searches, which results in unavoidable noise which in turn might disturb the owls. In summary, we are unable to recommend this method for estimating screech owl abundance.

MANAGEMENT IMPLICATIONS

Censusing eastern screech owls using playback of tape recorded song provides a quick, relatively easy method for obtaining indices of population abundance, even by relatively untrained personnel. Censuses repeated at time intervals sufficient to decrease accommodation to song playback provide consistent results which can be used to determine trends in seasonal and annual abundance, when weather and behavioral variations are considered. The only alternative methods that can provide similar information are extremely time consuming, require individuals with a considerable degree of expertise, and should be repeated at reasonable intervals to obtain accurate abundance estimates. Information provided by song playback can also be used to evaluate correlations between screech owl abundance and habitat variables.

To some extent certain aspects of the screech owl population may be ascertained using song playback including (1) time of pairing or intensity of the pair bond as determined by weeks in which pairs respond at particular stations (2) approximate home range estimates where individuals visually observed have distinctive plumage patterns or distinctively pitched song and (3) information on boundaries of home ranges, where adjacent pairs respond simultaneously to the song playback.

The feasibility of song playback censuses to estimate owl abundance may best be illustrated using examples from our studies. Song playback revealed the presence of a minimum of 2 individuals each on 2 woodlots near Elizabethtown, Pennsylvania. All 4 owls were visually observed in early evening hours several times over a 3 month period, confirming their use of the isolated woodlots.

Table 9.--Observed frequency of eastern screech owls "sunning" at cavity entrances.¹

Time ²	January	February	March	April ³	November	December
0530-0729	2/18 (11.1)	1/ 7 (14.3)	--	0/3 (0.0)	--	0/ 8 (0.0)
0730-0959	4/27 (23.5)	3/16 (18.8)	--	--	--	0/ 4 (0.0)
1000-1259	15/27 (55.6)	7/12 (58.3)	3/ 7 (42.9)	--	--	2/11 (18.2)
1230-1359	20/42 (47.6)	7/12 (58.3)	--	2/5 (20.0)	--	4/ 7 (57.1)
1400-1629	18/27 (66.7)	10/13 (76.9)	10/17 (58.8)	2/3 (66.7)	6/12 (50.0)	13/17 (76.5)
1630-Dark	21/30 (70.0)	11/12 (91.2)	12/14 (85.7)	3/3 (100.0)	9/ 9 (100.0)	10/16 (62.5)

¹Numbers represent owls observed at entrance per known owl roostings, percent in parenthesis. Totals vary as a function of the number of times we were able to check a known owl roost each day.

²Includes observations recorded only on uniformly sunny days.

³All observations for this month were of a male.

DGS attempted to locate the roost sites of these owls during daylight hours by searching for pellet depositions, owl feathers and owl kills. Only 1 of the 4 was located in approximately 250 man hours, although all observed cavities were checked by ascents from 3 to 8 times during the 3 month period. In Oxford, AD found a pair that consistently responded within 10-50 sec to playback over a 12 day period. AD unsuccessfully spent approximately 30 hrs over a 3 week period attempting to locate a roost, by screech owl pellet deposition, signs of whitewash, screech owl feathers or kills.

The results of our studies lead us to suggest that playback provides the only effective method for estimating screech owl populations in our study areas in Pennsylvania and southern Connecticut. Furthermore, our synchronous attempts at obtaining population indices with a combination of alternative methods lead us to suggest that it is virtually impossible to obtain accurate indices of screech owl abundance by using any other method or combination of methods in extensively wooded areas.

SUMMARY

We surveyed eastern screech owl populations in southern Connecticut using song playback. Song playback provided consistent information on presence and abundance of screech owls throughout the year. Screech owls exhibited a seasonal frequency of response to playback, being most responsive during fall and winter months and less so during spring and summer. Response to song playback varied significantly with time of year, sequence and noise levels but not with weather conditions or moon phase.

The variation in screech owl response frequency with survey sequence suggests that at least some individuals may accommodate to song playback. Accommodation tests using radiomarked screech owls confirmed that some individuals accommodate to playback as a function of censusing frequency; owls censused at 7 and 14 day intervals showed much greater overall response rates compared to owls censused at 1 and 3 day intervals.

Population estimates obtained during fall and winter indicate sizeable screech owl populations that vary in density as a function of percent woodland. Comparison with population estimates obtained by a combination of playback, foot searches and visual confirmation suggests that song playback provided estimates within 15-30% of actual screech owl populations during months of maximum screech owl response.

We were unable to confirm reliability of counts of owls sunning at cavities during daylight hours as a method for locating and estimating screech owl populations.

ACKNOWLEDGMENTS

Bill Leng provided VAX mainframe technical expertise and helped in many ways in the preparation of this report. We are indebted to Debbie Gendron, Douglas Spencer, Mark Drummond and Anne Walsh for contributing many hours of fieldwork. We thank Thomas Bosakowski, Tom Carpenter and W. Bruce McGillivray for critically reviewing one or more earlier versions of this manuscript.

LITERATURE CITED

- Allaire, P. N., and D. F. Laundrum. 1975. Summer census of screech owls in Breathitt County, Kentucky. *Kentucky Warbler* 51:23-29.
- Bent, A. C. 1938. Life histories of North American birds of prey (Part 2). U. S. Nat. Mus. Bull. 170, 482 p.
- Catchpole, C. 1982. The evolution of bird sounds in relation to mating and spacing behavior. pp. 297-320 in D. E. Kroodsma, E. H. Miller and H. Ouellet, eds. *Acoustic Communication in Birds*, Volume 1. Academic Press. New York.
- Cink, C. L. 1975. Population of screech owls in Northeastern Kansas. *Kansas Ornithol. Bull.* 26:13-16.
- Craighead, J., and F. C. Craighead. 1956. *Hawks, owls, and wildlife*. Stackpole Co., Harrisburg, PA.
- Devine, A. 1982. Ecology of the screech owl (*Otus asio*) in southern Connecticut. Unpublished Master's Thesis, Southern Connecticut State University, New Haven, Connecticut.
- Fuller, M. R., and J. A. Mosher. 1981. Methods of detecting and counting raptors: a review. *Studies in Avian Biology* 6: 235-246.
- Hough, F. 1960. Two significant calling periods of the screech owl. *Auk*. 77:227-228.
- Johnson, R. R., B. T. Brown, L. T. Haight and J. M. Simpson. 1981. Playback recordings as a special avian censusing technique. *Studies in Avian Biology* 6: 68-75.
- Kroodsma, D. E., E. H. Miller and H. Ouellet, eds. 1982. *Acoustic communication in birds*. Vol. 1. Academic Press. New York. 371 pp.
- Lynch, P. 1982. A tape census of screech owls (*Otus asio*) in urban open-space areas of New Haven, Connecticut. Unpublished Master's Thesis. Southern Connecticut State University, New Haven, Connecticut.
- Marion, W. R., T. E. O'Meara, and D. S. Maehr. 1981. Use of playback recordings in sampling elusive or secretive birds. *Studies in Avian Biology* 6: 81-85.

- Preston, C. R. 1980. Differential perch site selection by color morphs of the red-tailed hawk (Buteo jamaicensis). *Auk*. 97:782-789.
- Smith, D. G., and R. Gilbert. 1984. Screech owl home range and use of suburban habitats in southern Connecticut. *J. Field Ornithol.* 55:322-329.
- Smith, D. G. 1981. Winter roost site fidelity of long-eared owls in central Pennsylvania. *Am. Birds* 35:339.
- Smith, D. G. 1979. Late summer call response of barred owls in northern Pennsylvania. *Cassinia* 58:25.
- Smith, D. G. 1986. Winter food of the long-eared owl in Pennsylvania. *Cassinia* 61:38-41.
- Springer, M. A. 1978. Foot surveys versus owl calling surveys: A comparative study of two great horned owl censusing techniques. *Inland Bird Banding News* 50:83-93.
- SPSS, Inc. 1983. *SPSS-X User's guide*. McGraw Hill Publ. Co., New York.
- Van Camp, L. F., and C. J. Henny. 1975. The screech owl: Its life history and population ecology in Northern Ohio. *No. Am. Fauna No.* 71. U. S. Fish Wildl. Serv., Wash., D. C.
- McGarigal, K., and J. D. Fraser. 1984. The effect of forest stand age on owl distribution in southwestern Virginia. *J. Wildl. Manage.* 48: 1393-1398.
- McGarigal, K., and J. D. Fraser. 1985. Barred owl responses to recorded vocalizations. *Condor* 87: 552-553.
- McNicholl, M. K. 1981. Caution needed in the use of playback to census bird populations. *Am. Birds* 35:235-236.
- Mosher, J. A., and C. J. Henny. 1976. Thermal adaptiveness of plumage color in screech owls. *Auk*. 93:614-619.
- Norwicki, T. 1974. A census of screech owls (Otus asio) using tape-recorded calls. *Jack-Pine Warbler* 52:99-101.
- Owen, D. F. 1963a. Variation in North American screech owls and the subspecies concept. *Systematic Zool.* 12: 8-14.
- Owen, D. F. 1963b. Polymorphism in the screech owl (Otus asio) in eastern North America. *Wilson Bull.* 75: 132-137.

Status of the Eastern Screech Owl in Saskatchewan with Reference to Adjacent Areas¹

Christopher I. G. Adam²

Abstract.--In 1985 and 1986, the author conducted censuses of Eastern Screech-Owls in southeastern Saskatchewan using tape playbacks. The survey, along with other recent and historical records, contributes to the first delineation of the species' range in Saskatchewan. The Saskatchewan population lies at the northwestern extent of the species' range in North America, and is placed in a regional context by examining the occurrences of the screech-owl in Manitoba, Montana, North and South Dakota and Alberta.

INTRODUCTION

In Saskatchewan, the Eastern Screech-Owl (*Otus asio maxwelliae*) is a rare resident of riparian habitat in the southeastern portion of the province, chiefly along the Souris River, Wascana Creek near Regina, and north to Yorkton and Duck Mountain Provincial Park. To date, very little has been published concerning the status of screech-owls in western Canada. Penak (1985)³ summarised the knowledge of the Canadian range of the species.

The Eastern Screech-Owl is common throughout most of eastern North America from southern Manitoba south to Texas. It reaches the northern extent of its range in southern Ontario and Manitoba. The range of the Western Screech-Owl (*O.a. kennicottii*), which was recently split from *asio* (American Ornithologists' Union 1983), extends into western Montana and the western and southern interior of British Columbia (Godfrey 1986) south to Mexico.

Otus asio is a small arboreal horned owl which stands about 22 cm tall. In Saskatchewan, the *maxwelliae* subspecies exists in two colour phases, pale gray and the rarer pale red. In the

prairies, the screech-owl is restricted to tree cavities in riparian Manitoba maple (*Acer negundo*) habitat.

Censusing screech-owls by playing tape recorded calls has been used by Carpenter (these proceedings) in Michigan; Cink (1975) in riparian woodland in Kansas; Johnson et al. (1981) in riparian woodland in Arizona; Lynch and Smith (1984) and Smith et al. (these proceedings) in urban open-space areas Connecticut; Nowicki (1974) in Michigan; and Youmans along the Yellowstone River in Montana⁴.

Eastern Screech-Owls are one of three owl species which respond well to tape playbacks (Smith and McKay 1984). Although both sexes sing, it is by no means certain that only males respond. However, when a single owl responds to the taped call, it is likely the male of a presumed pair rather than an unmated bird. Caution must be exercised in the interpretation of results as it cannot be assumed that each owl responding is paired, or that there are no owls present if there is no response. McNicholl (1981) cautioned researchers using tape censusing techniques that there may be a seasonal variation in response to taped calls resulting in distortion of results.

This paper summarises the status of the Eastern Screech-Owl in Saskatchewan, reports on surveys conducted by the author along the Souris River in 1985 and 1986, and compares the Saskatchewan range with that in the neighbouring states and provinces of Manitoba, Montana, North and South Dakota and Alberta.

¹ Paper presented at the symposium, Biology and Conservation of Northern Forest Owls, Feb. 3-7, 1987, Winnipeg, Manitoba. USDA Forest Service General Technical Report RM-142.

² Christopher I.G. Adam is a freelance wildlife consultant and ornithologist, 2636 Argyle St., Regina, Sask., Canada, S4S 0K1.

METHODS

The 1985 and 1986 Censuses

In 1985, the author co-ordinated a census of Eastern Screech-Owls in southern Saskatchewan for the Saskatchewan Natural History Society (SNHS). This census took place in March and April of 1985 and used volunteers gathered mostly from the SNHS membership. A second census took place in March and April of 1986 with some of the same volunteers participating. Volunteers were assigned different areas of the province, and were supplied with topographic maps for each area, a set of instructions, and a tape of owl calls.

The Souris River Valley between Estevan and the U.S. border (figs. 1 and 2) was censused by the author between April 9-12, 1985 and April 21-24, 1986, from dusk until about midnight. Although most suitable habitat was surveyed, some was inaccessible due to the absence of roads or trails. The ideal survey situation, a stop every 0.5 kilometres, was impossible due to the sometimes limited access to the best river valley habitat.

At each stop, the owl tape was played and responses, if any, were noted and mapped. The owl call sequence used consisted of three "whinny" calls (descending trills), a "bounce" call and a "trill" (monotone trill) (Cornell Laboratory of Ornithology 1983). At each stop, complete sequences were played until a response was elicited or until a total of five sequences failed to elicit a response. Usually five to ten minutes was spent at each stop.

The same methods were used in 1986, except that the number of stops was reduced by eliminating areas of unproductive habitat. Calling owls were tracked down and observed by flashlight in the last two nights. This method



Figure 1.--Riparian Manitoba maple habitat along the Souris River east of Pinto, Saskatchewan.

required that the forested habitat be approached or entered rather than being censused from a road.

Although attempts were made to resurvey the areas in 1986 using the same volunteers, response to the survey was much lower. A media campaign conducted by the author produced some interesting records from members of the public. Letters were sent to various weekly and daily newspapers in the southeastern portion of the province, and a radio interview was conducted.

The Study Area

The Souris River, from its source near Weyburn in Saskatchewan, flows southeastwards through some excellent but discontinuous screech-owl habitat east of Estevan to the U.S. border where it continues into North Dakota. Southeast of Minot (and the junction of the Des Lacs River), it swings east then north and skirts the west side of the Turtle Mountains before entering Manitoba where it joins the Assiniboine River near Brandon.

The Souris River study area (fig. 2) consisted of about 95 kilometres of meandering river within a broad valley in the Mixedgrass Prairie Ecodistrict (Harris et al. 1983) of southern Saskatchewan, between Estevan and the Saskatchewan - North Dakota border. The typical habitat along the Souris River, and in all other areas where the author has heard screech-owls, is a continuous or discontinuous Manitoba maple river bottom woodland (fig. 1) within a meander or curve, and situated so that the meander creates a discrete patch of woods. The maples are mature and large, with twisted branches and numerous natural cavities.

SURVEY RESULTS

The Souris River Study Area

Between April 21 and 24, 1986, a total of 17 singles or pairs were heard and/or seen by the author and S. Fitzgerald in 53 stops between Estevan and the US border, compared with 8 in 1985 in 85 stops (table 1). All owls appeared to be the pale *maxwelliae* subspecies.

Owls responding to the taped calls approached to within 7 or 8 metres and usually sat on an exposed branch within 3 or 4 metres of the ground. A second team member was easily able to zero in on the call and locate the owl by flashlight. This proved to be an excellent way to determine the colour phase of the owl. The calls were not loud, and gave the impression that the owl was calling from several hundred metres away. Out of 8 owls censused in this way, 7 were actually observed. Approximately 90% of tape-attracted screech-owls can be seen this way but care must be taken not to alarm the owl or this method will be unsuccessful. In neither year were the owls calling on their own volition since April is a relatively late date to be censusing owls in Saskatchewan.

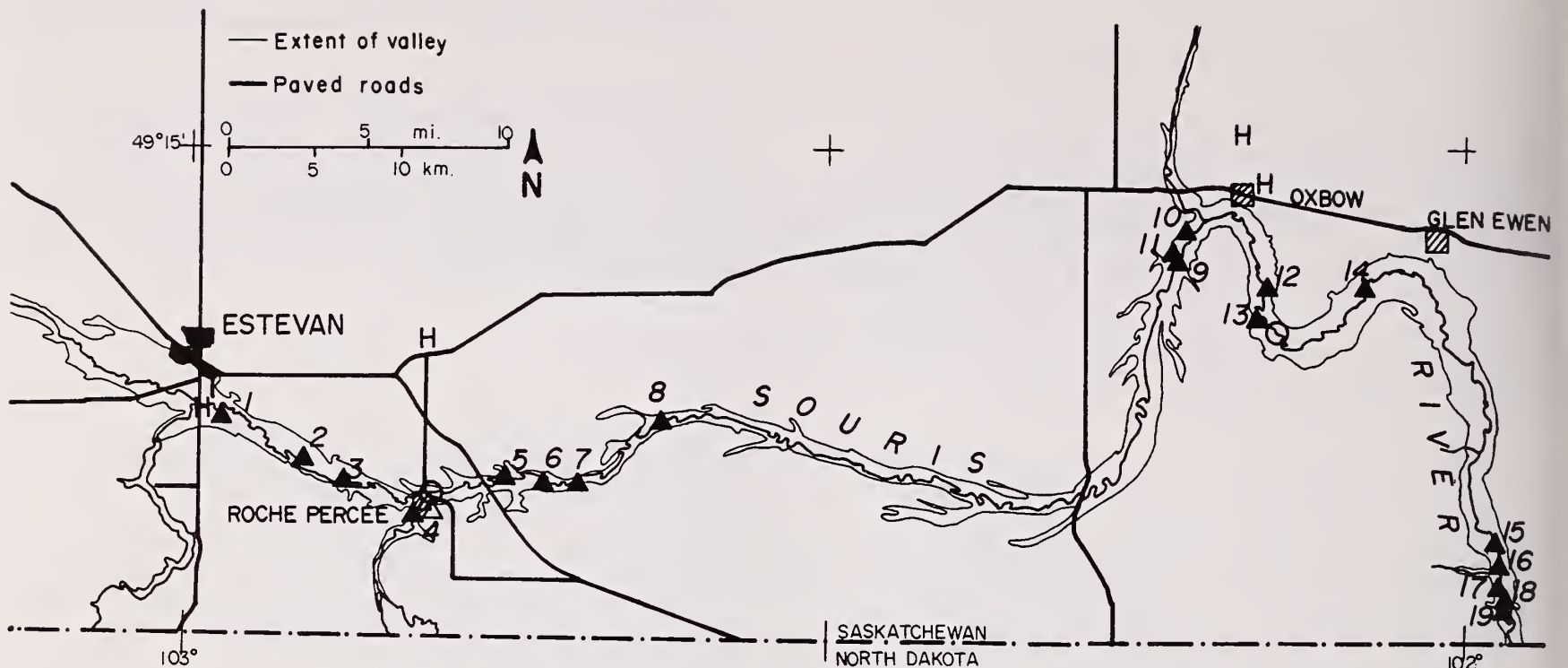

Figure 2.--The Souris River Study Area, Saskatchewan. ▲ = territorial records corresponding to the text and table 1. Additional records not mentioned in the text: H = hypothetical, O = pre-1979 non-territorial, and △ = pre-1979 territorial records.

There seem to be a number of "hotspots" in the Souris River for screech-owls, interspersed with areas of poor or no habitat (fig. 2). These are: (1) the Estevan to Pinto area, including Roche Percee; (2) the Oxbow area; and (3) the area south of Glen Ewen at the US border. Of the 8 owls seen, 1 was a probable gray-phase, 5 were definite gray-phase and 2 were red-phase. Both red-phase owls were at the Glen Ewen location.

The best responses to taped calls came early in the evening, until about two hours after sunset. It is, however, dangerous to draw any conclusions from this observation for three reasons: (1) the census was usually concluded around midnight, thus no responses were obtained for the remainder of the night; (2) since this is a dispersed population, the observers may have hit portions of the study area with no owls at about the time the responses seemed to taper off; and (3) the sample size was very low on any given night.

The majority of owls were associated with farms with haystacks and/or feedlots, or were near villages or houses. It may be significant that a long, mostly uninhabited stretch of the Souris River between Oxbow to about 16 kilometres south of Glen Ewen produced only one response. However, the stretch of the river immediately north of the U.S. border, south of Glen Ewen, had the densest population of screech-owls in the entire study area, about one territorial owl per 1 kilometre (compared to one owl per 3 or 4 kilometres in the rest of the study area).

The population in Saskatchewan appears to be low and scattered, as would be expected at the northwestern extent of the species' range. The total Saskatchewan population is "guesstimated" at 30 to 35 pairs, and is certainly no more than 50 pairs. Although the Souris River population seems to have increased, the increase is no doubt due to more efficient census techniques rather than an actual increase in birds.

DISCUSSION

The Range of the Eastern Screech-Owl in Western Canada and the U.S

The American Ornithologists' Union (1983) lists the range of both species of screech-owl in the relevant western states and provinces as follows: Eastern Screech-Owl - "Resident from southern Saskatchewan (probably), southern Manitoba, ... west to eastern Montana, the Dakotas ... Recorded in summer (and probably breeding) in central Alberta"; and Western Screech-Owl - "Resident from ... western Montana" south to southern Baja California.

The ranges of both species will be briefly examined for Saskatchewan, Manitoba, North Dakota, South Dakota, Montana and Alberta. The range in Saskatchewan is based upon a complete analysis of all records. The ranges in the remaining areas utilize personal communications, the relevant literature, and seasonal reports and Christmas Bird Count (CBC) summaries in *American Birds* (AB) and *Audubon Field Notes* (AFN). Some early

Table 1. Summary of 1985 and 1986 Souris River Screech-Owl censuses between Estevan - Roche Percee (ERP) and Oxbow - Glen Ewen (OGE). w = "whinny" (descending trill), and t = "trill" (monotone trill). A number of entries separated by commas indicates the number of different owls calling. Observers: C. Adam, S. Fitzgerald, except ERP 11 and ERP 15. Under Location, e refers to east of a given location, w to west of, etc. Numbers in brackets refer to mapped locations in fig. 2.

Date	Year	Stop#	Ref.No.	Location (1-19)	Calls	Phase
Apr 21	86	86-3	ERP 03	Estevan (1)	lw,lt	
Apr 09	85	85-13	ERP 04	se of Estevan (2)	3w	
Apr 21	86	86-5	ERP 05	se of Estevan (2)	t	
Apr 21	86	86-7	ERP 06	se of Estevan (3)	t	
Apr 09	85	85-22	ERP 10	Roche Percee (4)	w,t (pair)	
May 25	85	---	ERP 11	e of Roche Percee (5)	calls	
Apr 22	86	86-19	ERP 12	e of Roche Percee (5)	lt,lt,sev w	
Apr 22	86	86-22	ERP 13	w of Pinto (6)	6t	
Apr 22	86	86-23	ERP 14	Pinto (7)	w	
Apr 29	86	---	ERP 15	Pinto (7)	t,?	
Apr 10	85	85-44	ERP 16	sw of Hirsch (8)	t	
Apr 22	86	86-29	ERP 17	sw of Hirsch (8)	3t	
Apr 11	85	85-55	OGE 02	sw of Oxbow (9)	t	
Apr 23	86	86-33	OGE 04	sw of Oxbow (10)	t	
Apr 11	85	85-57	OGE 03	sw of Oxbow (11)	w,t (pair)	Gray
Apr 23	86	86-40	OGE 06	s of Oxbow (12)	t	Gray
Apr 23	86	86-38	OGE 08	s of Oxbow (13)	t	Gray
Apr 24	86	86-52	OGE 09	sw of Glen Ewen (14)	t	Gray
Apr 12	85	85-65	OGE 11	s of Glen Ewen (15)	t	
Apr 24	86	86-48	OGE 12	s of Glen Ewen (15)	t	Gray
Apr 12	85	85-66,72	OGE 13	s of Glen Ewen (16)	t	
Apr 24	86	86-47	OGE 14	s of Glen Ewen (16)	t	
Apr 12	85	85-73	OGE 15	s of Glen Ewen (17)	t,t (pair)	
Apr 24	86	86-46	OGE 16	s of Glen Ewen (17)	t	Gray?
Apr 24	86	86-45	OGE 17	s of Glen Ewen (18)	t	Red
Apr 24	86	86-44	OGE 18	s of Glen Ewen (19)	t	Red

records, recorded before the split into two species, are cited only as "screech owl". This analysis is not intended to be exhaustive. It does, however, serve to place the Saskatchewan range of the Eastern Screech-Owl into a regional context. Since this is an overview paper, only some American Birds records are referenced, and then only in the text. Figure 2 portrays the Souris River Study Area, and figure 3 portrays the range of the Eastern Screech-Owl at the northwestern extent of its range in North America. Numbered areas in the discussion refer to locations in figure 3.

Saskatchewan

Godfrey (1966) included the Regina area and parts southeast within the range of the Eastern Screech-Owl but has recently dropped that portion of the range and represented it by a "?" (Godfrey 1986). Godfrey (1966, 1986) also places a "?" in southwestern Saskatchewan. The former range delineation is more appropriate to the present situation. Scott (1983) includes only the extreme southeastern corner of the province and Marshall

(1967), the entire southern portion south of Regina.

The author has collected over 100 Saskatchewan screech-owl records from 1880 to date. These, including the records obtained during the 1985 and 1986 censuses and letter campaign, will be described in detail in a later paper (Adam [n.d.]⁵). To save space, some unpublished sources are cited as Adam [n.d.]⁵.

Southeast.--The core of the Eastern Screech-Owl range in Saskatchewan is the Souris River (1) east of Estevan, with concentrations at Estevan to Roche Percee, Oxbow to Glen Ewen, and at the Saskatchewan / North Dakota border (fig. 2). The modern occurrences correspond to historical references, indicating that there has been a viable population along the Souris River since at least the 1920's. The majority of records are of birds on territory that were censused by the use of tape playbacks. Records away from the river valley probably correspond to the fall and winter dispersal of young birds, or are of adults looking for food. Recent records

from the headwaters of the Souris River (2) indicate that screech-owls occur there occasionally (Adam [n.d.]⁵).

Central.--Pockets of maple woods along Wascana Creek (3) near Regina have supported from zero to three pairs of screech-owls in the recent past (Adam [n.d.]⁵). Such fluctuations are probably typical of a peripheral population. There are also several pre-1961 fall and winter records for the city of Regina (Belcher 1980) and recent records for north of Moose Jaw (3) (eg. AB 33:781-782). The city of Moose Jaw (4) has harboured a territorial owl for the last several years in a pocket of typical maple habitat along the Moose Jaw River. A fledgling extracted from a chimney there in 1979 (AB 34:172-174) is the only evidence of the breeding of this species in Saskatchewan.

The Qu'Appelle River valley seems ideal for screech-owls in some localities, but only Katepwa (5) has produced confirmed records of territorial owls (Adam [n.d.]⁵; Callin 1980). No records exist for the eastern portion of the valley, although the area has potential for screech-owls.

East.--Generally, screech-owls are absent from the almost treeless prairie north and east of the Souris River (6), although there are some historical records of non-territorial owls (Adam [n.d.]⁵). A few scattered records exist for the area between the Qu'Appelle and Souris rivers, including two historical records of calling birds from the southern edge of Moose Mountain Provincial Park (Adam [n.d.]⁵; Nero and Lein 1971). The maple habitat in this region appears to be rare, and few surveys have been conducted.

Northeast.--Yorkton area (7) records include several non-territorial and one territorial screech-owls, indicating the presence of a small semi-permanent population (Adam [n.d.]⁵; Hjertaas 1986; Houston 1949; Pollock 1986). There are recent records of calling birds from Duck Mountain Provincial Park (8) (Adam [n.d.]⁵; Hatch and Weidl 1981⁶; Soper 1970⁷). A 1979 record of a calling bird from the Porcupine Hills (9) is the most northerly in Saskatchewan (AB 33:872-873).

North.--Two extralimital records (1970's) from the city of Saskatoon (10) indicate the accidental presence of both the western (hypothetical) and eastern species (Adam [n.d.]⁵).

Southwest.--Two areas in southwestern Saskatchewan have produced four screech-owl records, indicating that the species' status is extremely rare and local. Recent screech-owl records from the Frenchman River (11), and Eastend (12) may represent birds which have moved up the Frenchman River from the Milk River in Montana (Adam [n.d.]⁵). The Cypress Hills owl (13) (AB 39:451-452), although not identified to species, is probably an Eastern Screech-Owl which may have moved up the Battle River from the Havre, Montana, area, also on the Milk River.

Manitoba

Southern Manitoba is within the continuous range of the Eastern Screech-Owl according to Godfrey (1986), Marshall (1967) and Scott (1983), although the portrayal of the three ranges differs slightly. Godfrey (1986) suggests that the subspecies O.a. swenki, a pale race with two colour phases, is the bird in southwestern Manitoba, and that it grades into the darker naevius (the widely distributed eastern subspecies) at Winnipeg and Whitemouth. Marshall (1967) considers swenki to be included within maxwelliae. Sources include American Birds reports and CBCs, personal communications, Manitoba Museum of Man and Nature files (specimens and nest records)⁸ (Adam [n.d.]⁵); and published literature.

Southwest.--There are a few scattered records for southwestern Manitoba, ranging from Riding Mountain National Park in the north to Lyleton in the extreme southwest. There are several observations dating from 1972 from the Lyleton area (14), including Knapton's (1979) records of calling birds and flightless young and other similar records from the 1980's. Lyleton is only about 80 km northwest of the Bottineau / Dunseith area of the Turtle Mountains of North Dakota (24) where there have been screech-owl records for years, and also about 60 km due east of a concentration of screech-owls in the southern part of the Souris River in Saskatchewan (1).

Other records come from the Sinclair and Reston area, where a family of screech-owls has hatched annually in the 1980s in or near a park in the latter (15). There are recent winter records from Brandon, Oak Lake and Rivers (16). Riding Mountain National Park (17) is also the site of a rare historical occurrence of a screech-owl (Penak 1985³; Soper 1953), which appears to be Manitoba's most northerly record.

Central.--There are a few scattered observations between southcentral Manitoba (18) and Lake Manitoba (19). The former area (18) includes two 1927 specimens from La Riviere on the Pembina River; a recent specimen from Cypress River; and documented nests from Roland (Copland 1986⁸).

The Winnipeg Area.--Screech-owls appear to be well established in Winnipeg and area (20), the large number of records in no doubt due to the many observers. Specimens exist from Argyle, Dugald, Headingley, and St. Adolph (on the Red River); city parks and other areas are the source of several specimens and nest records (Copland 1986⁸).

The Eastern Forest.--Taylor (1983) describes some historical screech-owl records from Brokenhead and the Whitemouth area (21). There is no evidence that screech-owls are regular breeders in this region of the province.

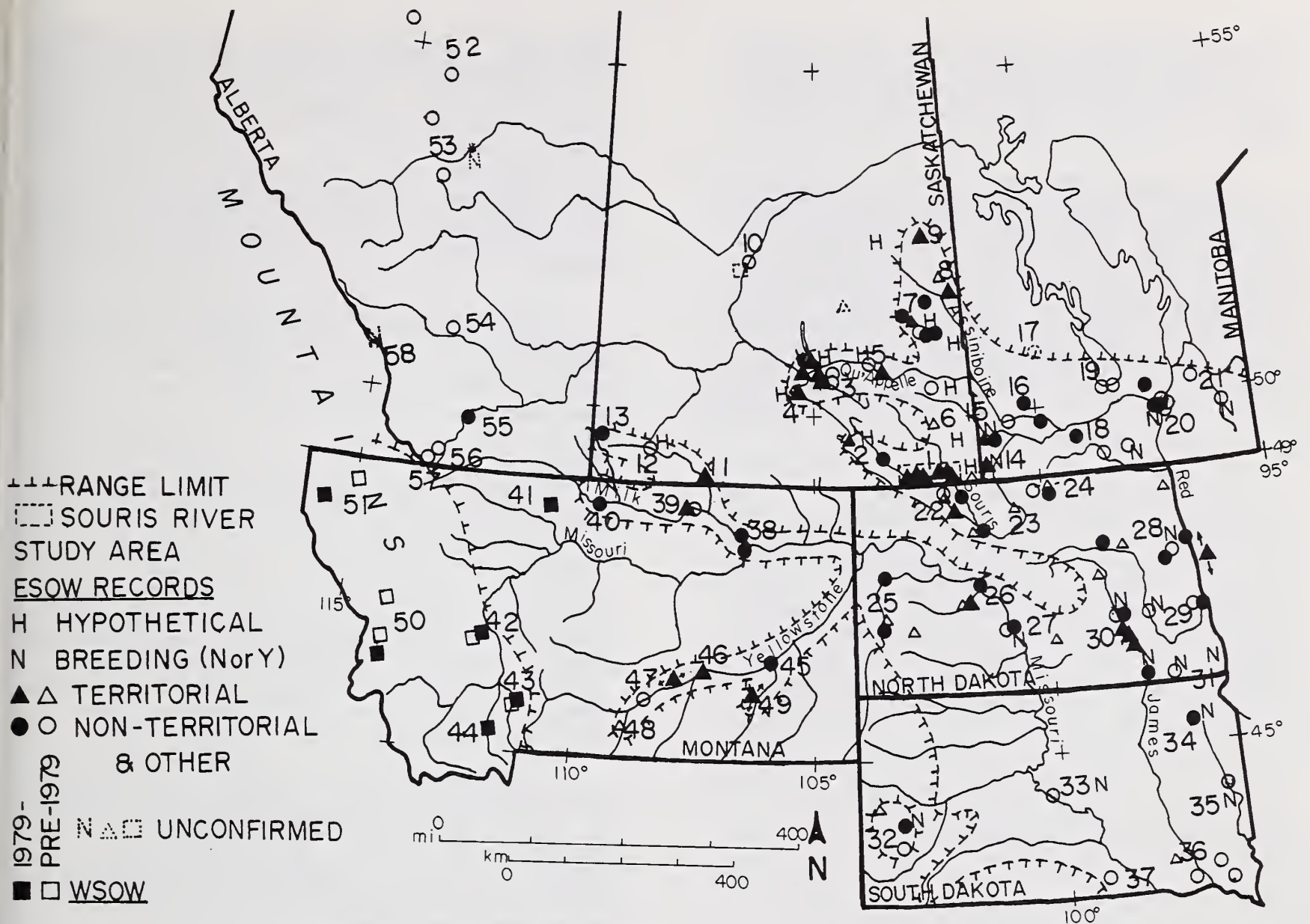

Figure 3.--The range of the Eastern Screech-Owl in Saskatchewan, Manitoba, North Dakota, South Dakota, Montana and Alberta. Numbers refer to locations described in the text.

North Dakota

Marshall (1967) and Scott (1983) include all of North Dakota within the range of the Eastern Screech-Owl. However, Johnsgard (1979) includes only the eastern portion of the state (east of the Missouri River), and the Turtle Mountains. There are many scattered records from the western part of North Dakota whereas the eastern part of the state is within the continuous portion of the screech-owl range. Recent records from *American Birds*, *Audubon Field Notes* and Stewart (1975) were used to update the range in the Dakotas and to compare it with that in Saskatchewan.

The Souris River.--The Des Lacs River, which joins the Souris at Minot, and the western portion of the Souris River are the sites of several records (22). These areas are situated within 100 kilometres of the concentration of screech-owls just over the Saskatchewan - North Dakota border in Saskatchewan. The Des Lacs National Wildlife Refuge (NWR) is the source of several pre-1975

winter screech-owl records (eg. AB 29:461), and the Upper Souris NWR on the Souris River northwest of Minot is the source of three recent winter records (eg. AB 40:879). At Carpio, further to the southeast on the Des Lacs River, a pair of screech-owls with six young was observed in 1979 (AB 33:874-875). Minot is the site of regular CBCs where screech-owls have been recorded since 1978 (eg. 40:878-879). The J. Clark Salyer NWR (23) on the Souris River northeast of Minot is the probable source of several pre-1972 records of territorial males or pairs (Stewart 1975), indicating breeding in this portion of the river. More owls will probably be found along the North Dakota portion of the Souris River if survey efforts are initiated.

The Turtle Mountains.--The Turtle Mountains (24) are an extension of Manitoba's Turtle Mountains and Turtle Mountain Provincial Park, which lies east of Lyleton (14), the site of several screech-owl breeding records. The area is given a disjunct range representation in Johnsgard (1979). The Turtle Mountains are the site of

several pre-1972 records of territorial males or pairs (Stewart 1975). There is a summer record from Bottineau (AFN 23:712-713) and two recent winter records from Dunseith (AB 38:684 and AB 39:677).

The Missouri River.--Western North Dakota has recent winter records from Medora (AB 38:685 and AB 39:678) and the North Unit of Theodore Roosevelt National Park, both on the Little Missouri River (25) (eg. AB 40:879); Garrison Dam on the Missouri River (26) (eg. AB 40:877-878); and Bismarck - Mandan, also on the Missouri River (27) (AB 40:877); and other records from the Beulah/Hazen area on the Knife River (26) (eg. AB 36:866-868). Nesting has also been confirmed from Burleigh and Kidder counties (east of the Bismarck area) (Stewart 1975).

The East.--Eastern North Dakota has screech-owl records centered at Grand Forks (28) (eg. AB 35:612) and Fargo (29) (eg. AB 32:741) on the Red River, well within the continuous Eastern Screech-Owl range. Nests and young have been found in Cass and Barnes counties (29), Stutsman and La Moure counties (30) and Richland county (31) (Stewart 1975). On Feb. 2, 1981, C.A. Faanes recorded responses to taped calls at eighteen locations along the James River between Jamestown and LaMoure (30) (AB 35:311-313). Jamestown is the site of numerous winter records (eg. AB 37:653-654). Lambeth (1986)⁹ estimates that there is more than 1 breeding pair of Eastern Screech-Owls per river-mile along the Red River and its tributaries (28, 29).

South Dakota

Eastern and central South Dakota, and the White River area and Black Hills are included in Johnsgard (1979), while Marshall (1967) and Scott (1983) include the entire state in the breeding range of the Eastern Screech-Owl. Because of the relative lack of information, figure 3 presents the range as given in Johnsgard (1979). Sources used in this summary consist of citations in American Birds and Audubon Field Notes.

The Black Hills (32) contain some records from Rapid City, including nesting records (eg. AFN 22:617-620). Central South Dakota has records from Pierre, on the Missouri River (eg. AB 40:880), and breeding records from Highmore to the east (eg. AB 34:906-907) (33). Other records are from Roberts County (downy young: AB 31:1150-1154) and Waubay National Wildlife Refuge (AB 40:881) in the northeast (34); the Brookings area in the east (35) (AB 32:220-223); Clay, Yankton and Hutchinson counties, and Hurley, in the southeast (36) (eg. AB 34:284-285); and the Burke area in the south-central portion of the state (37) (eg. AB 30:969-972).

Montana

Marshall (1967) and Scott (1983) place the eastern extent of the Western Screech-Owl range

along the Continental Divide of Montana's Rocky Mountains. However, these two authorities differ in portraying the western extent of the Eastern Screech-Owl range. Marshall (1967) shows a line extending due south from the Saskatchewan / Alberta border, while Scott (1983) includes only the Yellowstone River and southeastern Montana. Recent records from American Birds and the status of both kennicottii and asio by latilong in Skaar et al. (1985) were used to summarize the ranges in Montana.

The Milk River.--The Milk River, which joins the Missouri near Fort Peck, has several scattered "screech-owl" records: the Glasgow area (38) (eg. AB 34:284-285); Bowdoin NWR where screech-owls have been seen in nest boxes (39) (AB 33:782-784); and Havre (40), a 1981 winter record (AB 36:684). The Milk River is the probable source of the three recent Saskatchewan records: the Frenchman River (11) and Eastend (12) via the Frenchman River from the Bowdoin / Glasgow / Fort Peck area; and the Cypress Hills (13) via the Battle River from the Havre area. Chester (41), southwest of the Milk River but still within the region, is the site of a Western Screech-Owl identified on a 1982 CBC (AB 37:696). Based on the assumed ranges of both species, the Havre and Chester owls are probably Eastern Screech-Owls and not westerns, unless a diagnostic song was heard.

The Missouri River.--Records for the Missouri are very few, and include Fort Peck (38) (Skaar et al. 1985); and Helena (42) (AB 37:202-204), Bozeman (43) (eg. AB 37:696) and Ennis (44) (AB 37:696), in the Rocky Mountains. Both Bozeman and Ennis are the sites of recent winter records of the Western Screech-Owl.

The Yellowstone River.--The Yellowstone River also supports scattered Eastern Screech-Owls, with records from Miles City (45) (AB 37:312-314); the Hysham area (46), where 10 screech-owls were censused along a ten-mile route (Lambeth 1986)⁹; the Billings Latilong (47), where breeding has been confirmed (Skaar et al. 1985); Joliet (48) (AB 30:87-90); and the Tongue River (49), where census routes have consistently yielded screech-owls (Lambeth 1986)⁹.

The Mountains.--There are several definite Western Screech-Owl records from near the western border of Montana, west of the Continental Divide (50, 51) (eg. AB 38:727). These will not be considered in this paper.

Alberta

Although I have not been able to confirm any of the Alberta records (Salt and Salt 1976; Penak 1985³), most are probably Eastern Screech-Owls except possibly those from Waterton Park. The most northerly records are from Flatbush and Kinuso in the Swan Hills region (52). There also have been records from the Edmonton area (53), including Belvedere, Eilerslie and Pigeon Lake. There is also a 1950's record from east of Calgary

(54) and one from the Lethbridge area (55). The most southerly records are from Cardston (56) and Waterton Lakes National Park (57). An 1897 breeding record from Banff (58) is the earliest record.

The Waterton birds may have been extralimital Western Screech-Owls, but they are undoubtedly unconfirmable sight records. The southern birds may have moved in from Montana and Saskatchewan. The Banff bird may have been a Western Screech-Owl. The Eastern Screech-Owl should probably be listed as accidental for Alberta.

CONCLUSIONS

Investigations into the range and status of the Eastern Screech-Owl in Saskatchewan have shed some light on the situation in Manitoba, North Dakota and Montana. South Dakota and Alberta have not been examined as closely due to the relative lack of data. The range delineation (fig. 3) is still preliminary in nature, pending further documentation. The situation is complicated by the fact that *Otus kennicottii* was split from *Otus asio* only in 1983 (AOU 1983). Earlier records are thus not directly separable.

It is clear that the Souris River in southeastern Saskatchewan is the centre of the range in that province, with peripheral areas such as Moose Jaw, Regina, Yorkton and Duck Mountain having low and occasional populations. Some isolated records indicate that owls have dispersed in winter from the Souris River, or have moved along the valley to other areas. Similar movements may account for the presence of owls along the Qu'Appelle and the Assiniboine rivers

³ Penak, B.L. 1985. The status of the Eastern Screech-Owl (*Otus asio*) in Canada with an overview of the status in North America. 127 p. Unpublished Report. World Wildlife Fund of Canada for the Committee on the Status of Endangered Wildlife in Canada.

⁴ Adam, C.I.G. [n.d.] The Eastern Screech-Owl in Saskatchewan. MS in preparation.

⁵ Youmans, C.C. 1986. Personal communication. Forsyth, Montana.

⁶ Hatch, D. and D. Weidl. 1981. Fauna inventory of Duck Mountain Provincial Park, Saskatchewan. 95 p. Unpublished report. Saskatchewan Tourism and Renewable Resources, Regina, Sask.

Soper, J.D. 1970. Unpublished field notes on the birds observed and collected in the province of Saskatchewan, Canada, in 1914, 1921, 1927 and from July 1937 to September 1947. Unpublished report. Canadian Wildlife Service, Saskatoon, Sask.

Copland, H.W.R. 1986. Personal communication. Manitoba Museum of Man and Nature, Winnipeg, Manitoba.

Lambeth, D.O. 1986. Personal communication. Grand Forks, N.D.

(Yorkton area, Duck Mountain). However, the presence of owls in Regina and Moose Jaw may be better explained by owls moving across the intervening space between the Souris system and the Moose Jaw River and Wascana Creek.

Western Screech-Owls inhabit riparian habitat within the mountains of Montana, and Eastern Screech-Owls similar areas in the central plains (AOU 1983; Scott 1983). However, the northcentral portion of Montana appears to be in a state of flux. The preliminary range in this paper indicates that *asio* is gradually spreading westwards along the Yellowstone, Missouri and Milk rivers, and into Saskatchewan via the Frenchman and Battle rivers.

The situation in Montana and southern Alberta shows that the ranges of the two species are not yet set. This brings to light some interesting questions. The Chester and possibly the Havre owls may be *kennicottii*. Did they move east out of the mountains of Montana, were they misidentified, or were they unidentified *asio*? How far is *asio* moving west? Is *kennicottii* moving east, and how far? Are the Alberta owls, most of which are old records, *asio*, or are some of them *kennicottii*? Further studies and data collection may shed some light on this situation.

LITERATURE CITED

- American Ornithologists' Union. 1983. Check-list of North American birds, 6th edition. 877 p. Allen Press, Lawrence, Kansas.
- Belcher, M. 1980. Birds of Regina. Revised edition. Saskatchewan Natural History Society Special Publication No. 12, 151 p. Regina, Saskatchewan.
- Callin, E.M. 1980. Birds of the Qu'Appelle, 1857-1979. Saskatchewan Natural History Society Special Publication No. 13, 168 p. Regina, Saskatchewan.
- Cink, C.L. 1975. Population densities of Screech Owls in northeastern Kansas. Kansas Ornithological Society Bulletin 25:13-16.
- Cornell Laboratory of Ornithology. 1983. A field guide to bird songs of eastern and central North America. Second Edition. The Peterson Field Guide Series. Houghton Mifflin Co., Boston, Mass. (2 records.)
- Godfrey, W.E. 1966. The birds of Canada. 429 p. National Museums of Canada, Ottawa.
- Godfrey, W.E. 1986. The birds of Canada. Revised edition. 595 p. National Museums of Canada, Ottawa.
- Harris, W.C., A. Kabzems, A.L. Kosowan, G.A. Padbury, and J.S. Rowe. 1983. Ecological regions of Saskatchewan. Saskatchewan Parks and Renewable Resources Technical Bulletin No. 10, 57 p. Forestry Division, Saskatchewan Parks and Renewable Resources, Prince Albert, Saskatchewan.
- Hjertaas, W. 1986. Eastern Screech-Owl near Yorkton. Blue Jay 44(1):47.

- Houston, C.S. 1949. The birds of the Yorkton district, Saskatchewan. *The Canadian Field-Naturalist* 63:215-241.
- Johnsgard, P.A. 1979. Birds of the Great Plains. Breeding species and their distribution. 539 p. University of Nebraska Press, Lincoln and London, Nebraska.
- Johnson, R.R., B.T. Brown, L.T. Haight and J.M. Simpson. 1981. Playback recordings as a special avian censusing technique. p. 68-75. *In* Estimating numbers of terrestrial birds. Ralph, C.J. and J.M. Scott, editors. *Studies in Avian Biology* No. 6, Cooper Ornithological Society. Allen Press, Lawrence, Kansas.
- Knapton, R.W. 1979. Birds of the Gainsborough - Lyleton region (Saskatchewan and Manitoba). Saskatchewan Natural History Society Special Publication No. 10, 72 p. Regina, Saskatchewan.
- Lynch, P.J. and D.G. Smith. 1984. Census of Eastern Screech-Owls (*Otus asio*) in urban open-space areas using tape-recorded song. *American Birds* 38(4):388-391.
- Marshall, J.T. 1967. Parallell variation in North and Middle American screech owls. Western Foundation of Vetebrate Zoology, Monograph No. 1, 72 p.
- McNicholl, M.K. 1981. Caution needed in use of playbacks to census bird populations. *American Birds* 35(2):235-236.
- Nero, R.W. and M.R. Lein. 1971. Birds of Moose Mountain Saskatchewan. Saskatchewan Natural History Society Special Publication No. 7, 55 p. Regina, Saskatchewan.
- Nowicki, T. 1974. A census of Screech Owls (*Otus asio*) using tape recorded calls. *The Jack-Pine Warbler* 52:98-101.
- Pollock, C. 1986. An unusual visitor. *Blue Jay* 44(3):196.
- Salt, W.R. and J.R. Salt. 1976. The birds of Alberta. 498 p. Hurtig Publishers, Edmonton, Alberta
- Scott, S.L., editor. 1983. National Geographic Society field guide to the birds of North America. 464 p. National Geographic Society, Washington, D.C.
- Skaar, D., D. Flath and L.S. Thompson. 1985. P.D. Skaar's Montana bird distribution. Revised edition. Monograph No. 3, Montana Academy of Sciences, Supplement to the *Proceedings*, Vol. 44.
- Smith, D.G. and B. McKay. 1984. The effects of weather and effort on Christmas Bird Counts of owls in Connecticut. *American Birds* 38(4):383-387.
- Soper, J.D. 1953. The birds of Riding Mountain National Park, Manitoba, Canada. Canadian Wildlife Service Wildlife Management Bulletin, Series 2, No. 6., 54 p. Ottawa.
- Stewart, R.E. 1975. Breeding birds of North Dakota. Tri-College Centre for Environmental Studies, Fargo, N.D.
- Taylor, P. 1983. Wings along the Winnipeg. The birds of the Pinawa-Lac du Bonnet region, Manitoba. Manitoba Naturalists Society Eco Series No. 2, 223 p. Winnipeg, Manitoba.

Effects of Environmental Variables on Responses of Eastern Screech Owls to Playback¹

Thomas W. Carpenter²

Abstract.--Seventeen woodlots were censused for Eastern Screech-Owls using the playback technique from January of 1983 to August of 1984 to examine the effects of cloud cover, temperature, season, wind, and the lunar cycle on playback responses. Cloud cover, the lunar cycle, and winds under 25 kmph had no significant effects on the ability to find Eastern Screech-Owls with playback. The mean response latency was significantly less in winter than spring. Fewer birds were found when temperatures were below -12 °C.

INTRODUCTION

Many investigators have used playback in studies of the Eastern Screech-Owl, *Otus asio* (Casner 1974, Nowicki 1974, Cink 1975, Beatty 1977, Ellison 1980, Smith and Walsh 1981, Andrews et. al. 1982, Lynch and Smith 1984, Mutter et. al. 1984). Despite such widespread use, the influence of environmental factors on the results of playback studies has received little attention. In this study I examined whether the lunar cycle, season, cloud cover, temperature, and moderate (9-24 kmph) versus light (0-8 kmph) winds had any significant effects on the responses of the Eastern Screech-Owl to playback.

METHODS

Using playback, I censused 17 southeast Wisconsin woodlots for Eastern Screech-Owls from 16 January 1983 to 20 August 1984. Each woodlot was censused at 3 to 6 wk intervals. All woodlots were known to have at least one resident Eastern Screech-Owl. During each census attempt I recorded the day of the lunar cycle, the temperature in °C, wind speed

in kmph and the percent of the sky covered by clouds (estimated to the nearest 5%). Response latency (the length of time from the initiation of playback to detection of a bird) was also recorded. No censusing was done when winds exceeded 25 kmph or during heavy precipitation as other investigators have shown these conditions to severely restrict the ability to detect owls (Simpson 1972, Siminski 1976, Whisler and Horn 1977, Forsman 1983). Censusing was usually carried out between 0200 and 0500 and all censusing was done after 2000. Time of censusing between these limits was found to have no significant effect on the results of playback (Carpenter 1985).

The recording used in playback was taken from the Peterson record series A Field Guide to Bird Songs and consisted of a 12 min sequence: 3 min of calling, 1 min of silence, 3 min of calling, 1 min of silence, 3 min of calling and a final min of silence. The spacing between calls in the 3 min segments was 5 s. The recording was played from a Uher 4000 model tape recorder and amplified with a Nagra DH amplifier-speaker to a level of 92 dB. When birds were detected, playback was terminated. Otherwise, the 12 min playback procedure was completed. If birds were not detected after this it was assumed they would not respond.

The G test (Sokal and Rohlf 1983) was used to test for a relationship between each variable and the response rate to playback. One-way ANOVA's were used to test for any influence of each variable on mean response latency. The Tukey-Kramer method was used to deter-

¹Paper presented at the symposium, Biology and Conservation of Northern Forest Owls, Feb. 3-7, 1987, Winnipeg, Manitoba. USDA Forest Service General Technical Report RM-142.

²Thomas W. Carpenter, Department of Biological Sciences, University of Wisconsin-Milwaukee, Milwaukee, Wisc. Present address: 3646 S. John Hix, Wayne, Mich.

mine significant differences between means if a relationship was shown by the one-way ANOVA. Results were considered significant if $P < .05$.

Seasons used for this study were defined on the basis of the timing of significant events in this species annual cycle in southeast Wisconsin are as follows: winter (16 Dec to 15 Mar), spring (16 Mar to 15 Jun), summer (16 Jun to 15 Sept) and fall (16 Sept to 15 Dec).

RESULTS AND DISCUSSION

Temperatures less than $-12\text{ }^{\circ}\text{C}$ appeared to have an inhibitory effect on response rate (1 response out of 9 census attempts) but there were insufficient data to demonstrate this statistically (table 1). Casner (1974) found that "bitterly cold" temperatures diminished success and Smith and McKay (1984) noted there was an increase with warmer temperatures in the numbers of Eastern Screech-Owls reported on Christmas Bird Counts. Winter temperatures well below normal should be avoided as they appear to affect significantly the results of playback with this species.

I did not observe any relationship between the phase of the moon and response latency ($F = 1.13$, $df = 2$, 88, NS). Also, response rate to playback was not affected by the lunar cycle ($G = 0.82$, 2 df , NS). Johnson et. al. (1979, 1981) found Western Screech-Owls were most readily located with playback on nights



Figure 1.--Gray phase Eastern Screech-Owl
Photograph by Lee A. Carpenter.

Table 1.--The effect of temperature on response rates.

Temperature	No. of census attempts with a response	No. of census attempts without a response	Totals
-19 to $-7\text{ }^{\circ}\text{C}$ ¹	20	22	42
-6 to $-1\text{ }^{\circ}\text{C}$	5	8	13
0 to $5\text{ }^{\circ}\text{C}$	22	21	43
6 to $11\text{ }^{\circ}\text{C}$	15	13	28
12 to $17\text{ }^{\circ}\text{C}$	21	10	31
18 to $25\text{ }^{\circ}\text{C}$	<u>14</u>	<u>15</u>	<u>29</u>
Totals	97	89	186

$G = 4.64$, $df = 5$, $P > .05$

¹When temperatures were -19 to $-12\text{ }^{\circ}\text{C}$ one response was obtained out of 9 census attempts. This data had to be combined with the next temperature category (-11 to $-7\text{ }^{\circ}\text{C}$) to satisfy the requirements for the statistical test used.

with a bright waxing moon.

I found no significant differences in response rates ($G = 0.50$, $df = 1$, NS) or response latency ($F = 0.23$, $df = 1$, 89, NS) for light (0-8 kmph) versus moderate (9-24 kmph) winds. Siminski (1976) and Whisler and Horn (1977) found wind to have a negative effect on playback success in locating Great Horned and Spotted Owls.

Season did not affect the rate of response ($G = 2.04$, $df = 3$, NS). However, there were seasonal differences in the numbers of owls detected per successful response. More birds were detected per successful response during July and August when young birds frequently responded. This late summer increase in numbers has been previously reported by Allaire and Landrum (1975) and Lynch and Smith (1984). Also, pairs of birds (as opposed to single birds) appear to respond most often during winter (table 2). Season also had an effect on response latency. The mean response latency for winter was significantly different from that of spring with birds responding most rapidly in winter and taking the longest to respond during spring (table 3).

Cloud cover did not affect either response latency ($F = 0.56$, $df = 3$, 87, NS) or the rate of response ($G = 1.86$, $df = 3$, NS).

In summary, the environmental factors

Table 2.--Single bird responses and responses of pairs of Eastern Screech-Owls with respect to season.¹

Season	No. of times only a single bird responded	No. of times a pair responded	Totals
winter	14	7	21
spring	18	3	21
summer	14	4	18
fall	<u>13</u>	<u>1</u>	<u>14</u>
Totals	59	15	74

¹The table only includes data from the 12 woodlots where pairs were present.

I studied had little effect on response to playback. Extremely low winter temperatures do seem to inhibit responses. The only variable examined that significantly affected response latency was season. My findings further reinforce playback as an effective method for studying Eastern Screech-Owls.

ACKNOWLEDGEMENTS

I wish to express thanks to Dr. Charles Weise who served as my thesis supervisor during this study and, along with Dr. Millicent Ficken, made many helpful suggestions on this manuscript. Also, Dr. James Reinartz provided valuable assistance with the statistics used in this study. The equipment necessary to conduct this research was provided by the University of Wisconsin-Milwaukee Field Station.

LITERATURE CITED

Allaire, P. N. and D. F. Landrum. 1975. Summer census of Screech Owls in Breathitt County. Kentucky Warbler

51:23-28.

Andrews, J. W., O. Komar and N. Komar. 1982. Bird Observations in Eastern Massachusetts 10:263-269.

Beatty, W. H. 1977. Attracting Screech Owls. Redstart 44:102-104.

Carpenter, T. W. 1985. The effects of environmental conditions on the responses of Eastern Screech-Owls to playback of recorded calls. M. S. thesis. Univ. of Wisc.-Milwaukee.

Casner, T. R. 1974. Winter owl census. Jack-Pine Warbler 52:45-46.

Cink, C. L. 1975. Population densities of Screech Owls in northeastern Kansas. Kansas Ornithological Society Bulletin 26:13-16.

Ellison, P. T. 1980. Habitat use by resident Screech Owls (*Otus asio*). M. S. thesis. Univ. of Massachusetts.

Forsman, E. D. 1983. Methods and materials for locating and studying Spotted Owls. USDA Forest Service General Technical Report PNW-162.

Johnson, R. R., B. T. Brown, L. T. Haight, and J. M. Simpson. 1981. Playback recordings as a special avian census-taking technique. Studies in Avian Biology 6:68-75.

_____, C. T. Haight, and J. M. Simpson. 1979. Owl populations and species status in the southwestern United States. Pp. 40-59 In Proceedings of symposium on owls of the west: their ecology and conservation. P. P. Schaeffer and S. M. Ehlers, eds. Tiburon, California, National Audubon Society Western Education Center.

Lynch, P. J. and D. G. Smith. 1984. Census of Eastern Screech-Owls (*Otus asio*) in urban open space areas using tape-recorded song. American Birds 38:388-

Table 3.--The effect of season on mean response latency.

Mean response latency in min					
winter	fall	summer	spring	F	df
3.23 + 2.02	3.90 + 2.95	5.32 + 3.41	5.65 + 2.83	3.65*	3, 87

* significant seasonal effect ($P < .05$; one-way ANOVA)

Means connected by the same line do not differ significantly ($P > .05$; Tukey-Kramer method)

- Mutter, D., D. Nolin, and A. Shartle. 1984. Raptor populations on selected park reserves in Montgomery County, Ohio. *Ohio Journal of Science* 84:29-32.
- Nowicki, T. 1974. A census of Screech Owls using tape-recorded calls. *Jack-Pine Warbler* 52:98-101.
- Siminski, D. P. 1976. A study of Great Horned Owl (*Bubo virginianus*) population density with recorded calls in northwestern Ohio. M. S. thesis. Bowling Green State Univ., Bowling Green, Ohio
- Simpson, M. B. 1972. Saw-whet Owl population of North Carolina's southern Great Balsam Mountains. *Chat* 36:39-47.
- Smith, D. G. and B. McKay. 1984. The effects of weather and effort on Christmas Bird Counts of owls in Connecticut. *American Birds* 38:383-387.
- _____ and D. T. Walsh. 1981. A modified Bal-Chatrri trap for capturing Screech Owls. *North American Bird Bander* 6:14-15.
- Sokal, R. R. and F. J. Rohlf. 1983. *Biometry*. W. H. Freeman, San Francisco, California.
- Whisler, S. and D. Horn. 1977. An investigation into the occurrence and habits of Northern Spotted Owls (*Strix occidentalis caurina*) in the Ukiah District, BLM, April-June 1977. Bureau of Land Management, Ukiah, California.

Current Status and Habitat Associations of Forest Owls in Western Montana¹

Denver W. Holt and J. Michael Hillis²

Abstract. Nine species of owls nest in the forests of western Montana. Except for the Great Horned Owl, little is known about the other species. Only one Flammulated Owl nest has been reported in Montana. Western Screech Owls are mostly associated with riparian zones. Barred and Great Gray Owl nest site information is minimal. Boreal Owls are believed to be associated with old-growth spruce/fir forests above 1,500 m elevation. Nesting Saw-whet Owls seem to be associated with old, large, ponderosa pine snags. There is currently little data available for resource managers to make sound land-use decisions. Surveys must be established to gain basic habitat preference information for the species group.

INTRODUCTION

Little is known about the status and the habitat requirements for forest owls in western Montana. Except for the Great Horned Owl (*Bubo virginianus*), which exists in almost all habitats throughout the State, resource managers have little information available on which to make sound land-use decisions that will maintain viable populations of forest owls. Even the most basic information regarding the potential impacts of timber harvest or firewood cutting on this species group is lacking. The purpose of this paper is to centralize the current status and present preliminary information on habitat distribution of these owls for resource managers, researchers, and interested persons in western Montana. In addition we ask, what are the responsibilities of United States Forest Service to this species group, and briefly comment on two management strategies often implemented.

Further, we provide general census information guidelines (Tables 1, 2, and 3) and data sheets (Appendices 1, 2, and 3) for western Montana should the need or interest occur.

Before any research or management goals can begin, we feel it is essential to provide a foundation to work from. The following species accounts, however minimal, are state-of-the-art information for eight forest owls in western Montana. We define western Montana as the portion of the Rocky Mountains from the Idaho/Montana border east to our arbitrary line (Fig. 1).

We have not included the Great Horned Owl because of its wide distribution and diverse habitat association in western Montana or the Eastern Screech Owl (*Otus asio*) because this species has yet to be found in the area covered by this map.

SPECIES ACCOUNTS

The following is a summary of information collected thus far including nest data collected by other individuals.

FLAMMULATED OWL (*Otus flammeolus*) - Skaar et al. (1985) list five records--all occurring in western Montana. More recently, Holt, et al. (submitted for publication) has added six recent records, including the first nest record for Montana. The Flammulated Owl is a cavity-nesting owl strongly associated with old-growth ponderosa pine (*Pinus ponderosa*) (Bull and Anderson 1978; Linkhart 1984; Reynolds and Linkhart 1984). In

¹"Paper presented at the Symposium, Biology and Conservation of Northern Forest Owls. February 3-7, 1987, Winnipeg, Manitoba. USDA Forest Service, General Technical Report, RM-142."

²Denver W. Holt, Research Associate, USDA, Lolo National Forest, Supervisor's Office, Missoula, Montana 59801.

J. Michael Hillis, Wildlife Biologist, USDA, Lolo National Forest, Supervisor's Office, Missoula, Montana 59801.

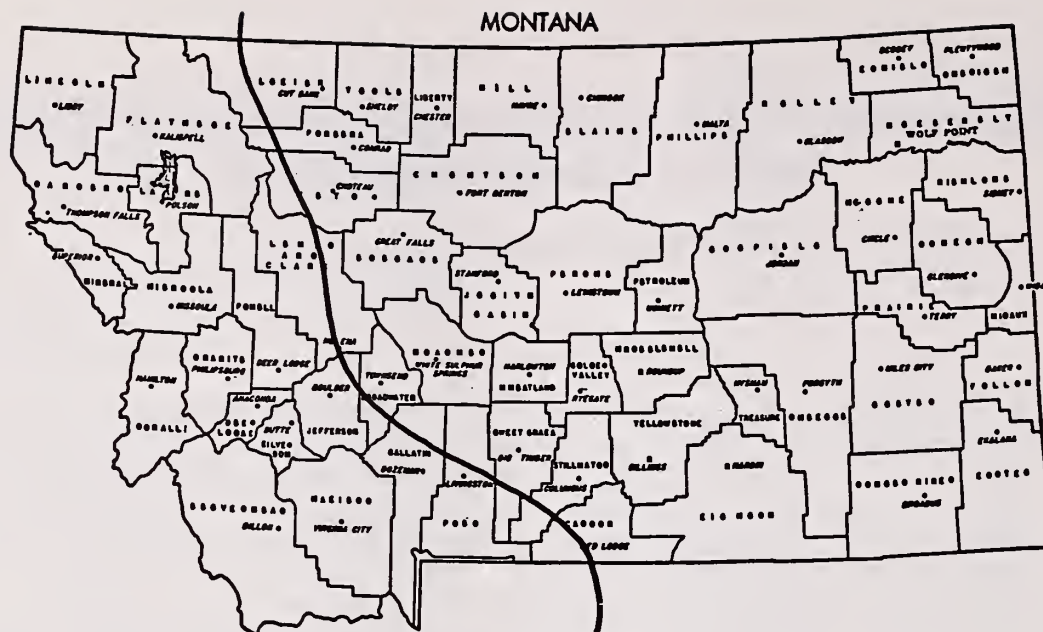

Figure 1. Area left of line delineated as Western Montana

Montana, the only vocalizing adult Flammulated Owls and present nest records are associated with old-growth ponderosa pine habitat (Holt, et al., submitted for publication). In the more southwestern limits of its range, ponderosa pine and Jeffrey pine (*Pinus jeffreyi*) were also used (Winter 1974). Marcot (1980) and Webb (1982), however, indicate an association of Flammulated Owls with mature California black oak (*Quercus kelloggii*) and quaking aspen (*Populus tremuloides*), respectively.

WESTERN SCREECH-OWL (*Otus kennicottii*) - Skaar (1975, 1980) listed numerous breeding and probable breeding locations for the Screech Owl (*Otus asis*) throughout western Montana. Since the recent split of the Screech Owl into two species, Western Screech Owl and Eastern Screech Owl (AOU 1983), problems concerning the distribution of these two species in Montana are being investigated. Of nine specimens from western Montana (Fig. 1), examined by Philip L. Wright, University of Montana Zoology Department, Missoula, Montana, all have been identified as the Western Screech Owl. This is the most current information we have to date. The only nest sites we could locate were: one in a natural cavity in a black cottonwood (*Populus trichocarpa*); one in a nest box attached to a black cottonwood; and one in a pileated woodpecker (*Dryocopus pileatus*) hole in a quaking aspen (B. R. McClelland, pers. comm.). Several observers have reported fledglings along cottonwood habitats surrounding Missoula, Montana. Vocalizing adults have been heard along major streams and rivers from 1976 to present (W. Kerling, pers. comm.) This is undoubtedly a more common species closely associated with riparian habitats. These habitats represent a small fraction of western Montana's forest zones and should be looked at more closely. Efforts to locate (by vocalization) forest owls throughout western Montana in 1984 and 1986 failed to elicit any Western Screech Owl responses in coniferous

forests at elevations ranging from 600 to 2,400 m in elevation, despite seven other owl species responding (Escano 1984; Holt 1986). However, these owls are occasionally observed in mixed coniferous forests away from riparian areas.

NORTHERN PYGMY-OWL (*Glaucidium gnoma*) - The Pygmy Owl is a common resident throughout the mountains of western Montana. Because of this owl's diurnal activity throughout the winter, it is commonly seen at bird feeders, on power lines along the road, or chasing flocks of wintering passerines. It is rarely seen, however, during the nesting season when it becomes more secretive and crepuscular. There is almost nothing known of its habitat requirements in North America (Norton and Holt 1982, Holt and Norton 1986). Observations and vocalization in western Montana indicate a preference of Pygmy Owls for mixed/fir or spruce/fir forests during the breeding season (D. Holt, unpub. data), although others have reported nests in old woodpecker holes in poplar and aspen trees (*Populus spp.*) in California and Oregon (Bendire 1888), western larch (*Larix occidentalis*) in Oregon (Munroe 1919), a natural cavity in a black oak in California (Holman 1926), and a woodpecker hole in an aspen tree in Oregon (Braly 1930).

BARRED OWL (*Strix varia*) - The Barred Owl appears to be a recent addition to Montana avifauna. However, Saunders (1921) reported two Barred Owls collected near Billings, Montana; but the specimens have never been located and there is some question as to their authenticity (P. D. Skaar, personal records). Early reports of Spotted Owls (*Strix occidentalis*) (Weydemeyer 1927, Hoffman et al. 1959, Hand 1969) in northwestern Montana may also be questionable (Wright 1976) and could represent earlier Barred Owl records. The first accurate records for a Barred Owl in Montana appeared on July 30, 1966 in Glacier National Park (Glacier National Park Bird Record Cards). Shea (1974) summarizes the

recent range expansion in western Montana, which seem to center around northwestern Montana. The first verified nest was reported on May 29, 1976 (Rogers 1976). Taylor and Forsman (1976) and Boxall and Stephney (1982) discuss range expansion of the Barred Owl and permanent residence in western North America and Alberta, respectively.

Despite 20 years of possible range expansion in Montana, few nests have been reported (Rogers 1976, 1979, 1982) and habitat associations are just beginning to be identified. Over the last 5 years near Libby, Montana, three Barred Owl nesting territories have been located. All were associated with mixed species of old-growth forest between 900 to 1,200 m in elevation; however, no actual nests have been found (A. Bratkovich, pers. comm.). In 1985, vocalizing adults and a probable nest site was located near Rainy Lake in the upper Clearwater River drainage of Montana. The nest was in a stand of scattered old-growth western larch (M. Hillis, pers. comm.). One Barred Owl nest reported, was found in the broken top of a live western larch approximately 1,200 m in elevation (R. Kuennen, pers. comm.). Over the past 10 years in Glacier National Park, four Barred Owl nests were found in broken-top old-growth western larch trees, approximately 1,000 m in elevation (B. R. McClelland, pers. comm.). Also, vocalizing adult Barred Owls during the breeding season have been associated with old-growth western larch stands in the Rattlesnake Wilderness Area, Missoula, Montana, from 1976 to present (W. Kerling, pers. comm.). Current surveys (D. Holt, unpubl. data) have located Barred Owls during the nesting season from 900 to 1,800 m elevation in riparian (one record), mixed larch, and lodgepole pine (Pinus contorta) habitats.

GREAT GRAY OWL (Strix nebulosa) - Skaar et al. (1985) list this owl as a fairly common resident throughout western Montana. However, there are only ten known nest records (Weydemeyer 1932; Hand 1969; Rogers 1972, 1975, 1976, 1977, 1979, 1982; Skaar pers. records) that we could locate, despite numerous sightings and suspected nesting areas. Most of these, however, were east of the Continental Divide. Great Gray Owls are typically associated with lodgepole pine/wet meadow ecotones east of the Continental Divide in Montana (S. Gniadek, pers. comm.). Escano (1984) reported Great Gray Owls occurring in lodgepole pine/wet meadow complexes between 1,500 to 2,300 m in elevation only east of the Continental Divide, despite surveys on both sides. West of the Continental Divide, J. Foote (pers. comm.) reported Great Gray Owls probably nesting in the last 4 to 6 consecutive years in spruce bogs near Ovando, Montana. In addition, D. Holt (unpubl. data) located Great Gray Owls in spruce/fir bogs approximately 1,800 m in elevation in western Montana. Nero (1980) also reported Great Gray Owls using nests in spruce bogs from Manitoba, Canada. There are enough sightings to indicate that this owl occurs regularly west of the Continental Divide in Montana, but surveys are

needed to locate breeding territories and nest trees.

LONG-EARED OWL (Asio otus) - While this is one of the more common owls in the State (Skaar et al., 1985), information concerning forest habitat preferences is lacking. Nesting of this species in old magpie (Pica pica) or American crow (Corvus brachyrhynchos) nests in dense deciduous vegetation in shrubsteppe desert is well documented (Marks 1986). Similar nest sites have been recorded in eastern (S. Gniadek, pers. comm.) and western (D. Holt, unpubl. data) Montana. They are reported to nest in woodlands bordered by meadows in Europe (Mikkola 1983). However, there seems to be a scarcity of information concerning habitat preferences in the coniferous forests of western Montana. Vocalizing adults have been heard in mixed Douglas-fir (Pseudotsuga menziesii) stands near Missoula, Montana (D. Holt, unpubl. data), and a stick nest was found in a lodgepole pine tree in Glacier National Park, Montana in July 1985 (Glacier Park Bird Record Cards). But, to what extent is this really a forest owl?

BOREAL OWL (Aegolius funereus) - Skaar et al., (1985) list 16 verified records for Montana. Though no nests have been located, three juveniles were observed in Glacier National Park by Dave Shea in July 1973. This constitutes the only evidence of breeding for the State. More recently, Escano (1984) and Holt (1986) have conducted specific surveys to locate Boreal Owls in western Montana. An additional specimen record (Holt et al., in press) and a sighting record (T. Ryan, pers. comm.) were also reported in 1986. Thus far, survey results indicate that Boreal Owls in western Montana prefer mature old-growth spruce/fir forests greater than 1,500 m in elevation, though east of the Continental Divide, some survey results were associated with lodgepole pine/wet meadow habitat. Hayward and Garton (1983) and Palmer and Ryder (1986) summarized the first nesting and documented nesting records for Boreal Owls in Idaho and Colorado, respectively. Status and distribution of this owl are slowly coming to light now that surveys to locate them are being conducted in the Rocky Mountain states.

SAW-WHET OWL (Aegolius acadicus) - Little information exists in the literature concerning Saw-whet Owls in western Montana. It appears to be a fairly common owl with wide distribution throughout the State (Skaar et al., 1985). Though generally associated with coniferous forests in Montana, Saw-whet Owls have also been located along cottonwood habitats (Youman, et al., 1981; W. Heron, pers. comm.). Of nine nest sites in western Montana from which we are familiar, seven were in dead ponderosa pine snags (D. Holt, unpubl. data), one was in a dead western larch snag (J. Kipphut pers. comm.), and one probable nest was also in a western larch snag (B. R. McClelland, pers. comm.). Two additional nesting territories located in 1986 were associated with mixed ponderosa pine/Douglas-fir habitat (D. Holt, unpubl. data).

SUMMARY OF SPECIES ACCOUNTS

We know very little about habitat requirements for most forest owls of western Montana. We are sure that there may be more information available for several of the species mentioned. Unfortunately, if it is not in the literature or locally reported, it is difficult to find. Five of the eight owl species (Flammulated, Western Screech, Northern Pygmy, Boreal, and Saw-whet) are dependent on tree cavities, either natural or excavated, for nest sites. The Barred and Great Gray Owls either nest in large broken-top snags or large stick nests made by other birds. Long-eared Owls nest in stick nests made by other birds. Seven of the eight species are directly associated to snags and mature or old-growth trees for nest sites. The Western Screech Owl is mostly associated with riparian habitats, which represent a small fraction of western Montana's forest zones. Threats to this habitat could have a great effect on this owl.

WHAT ARE THE RESPONSIBILITIES OF THE FOREST SERVICE?

Do forest management plans provide adequate habitats to maintain viable populations of western Montana's forest owls? Without baseline surveys to locate nesting areas, or more adequate habitat use data, there is inadequate information to answer this question.

With the exception of the Spotted Owl (*Strix occidentalis*), the U. S. Forest Service has not given much emphasis to owl management. This is contrary to the National Forest Management Act of 1976 (NFMA) which mandates that all wildlife species be managed for viable populations. However, with over 500 vertebrate species this would be difficult for any organization. Recognizing the absence of detailed information on owl habitat, the apparent association of owls with snags, mature, and old-growth timber (both rapidly declining), it seems inconsistent that the U. S. Forest Service has placed little emphasis on owl management. One might conclude that the agency's painful experiences with the Spotted Owl in Oregon and Washington have evolved into a "hear no evil, see no evil" approach for other forest owls as well. Fortunately, that attitude may be changing. Some positive signs of that change include: 1) adoption of a Montana sensitive species list that includes two owls--the Great Gray and Boreal; and 2) a commitment to fund intensive inventories for several sensitive species each year. Unfortunately, no species of owls were selected for inventory in 1987.

We suggest an approach to protecting Montana's forest owl populations to include the following steps:

1. An inventory of owl nesting distribution;

2. Cooperation with researchers to define nest-stand selection, territory size, prey base, and population status; and
3. Development of a management strategy for maintaining viable populations for each forest owl species into individual Forest Plans.

The above three steps would allow the U. S. Forest Service to appropriately modify timber harvest and firewood activities in a way that guarantees population viability for forest owls.

"INDICATOR" SPECIES

Using indicator species to indicate effects of management on a variety of species is a commonly used concept. For instance, using the Pileated Woodpecker in western Montana as an indicator for species dependent on old-growth larch-fir forests is "the key to retaining a complete community of hole-nesting birds" (McClelland 1977). For some snag dependent owls, such as the Flammulated, Western Screech, Barred, and Saw-whet, the Pileated Woodpecker may be a useful key. However, this may not help the Northern Pygmy, Great Gray, Long-eared, and Boreal Owls, which appear to be dependent on different habitats. Also, indicator species used in one area may not be applicable to another area. Without basic knowledge of what owls occur in which habitats, how can an indicator species be useful for the species group?

ARTIFICIAL NEST SITES

Artificial nest sites have been used to either manage, protect, or increase wildlife populations. Many of these programs have been successful to help reestablish certain species or gain certain biological information. But to introduce artificial nest sites for convenience or to increase populations not in jeopardy is of questionable value. This turns into single species or group species management, which undoubtedly effects other species of the community. If artificial nest sites are needed temporarily to gather some important information, they should be used temporarily and then removed. For some species, artificial nests may be needed, but to use this tool for managing forest owls in lieu of an active habitat research and management program is unwise. We state this obvious point to challenge the inevitable "quick fix" philosophy that federal agencies or industry groups utilize which often implies that many wildlife problems can be solved with a bird box. Artificial nest sites should be used only where and when it is the last alternative to maintain or reestablish a population in jeopardy. Only habitats that a given species is known to nest in should be influenced. And, when planning such projects, we should seek to approximate the levels of viable

populations that may have been found in other studies of natural populations.

If we go beyond this, then we become like game managers, producing the animals we like best and ignoring the overall continuity of natural community.

CONCLUSION

We have tried to emphasize the lack of information on forest owls in western Montana and the immediate need for baseline surveys. Many of the species may be dependent on snags, mature, or old-growth timber for nest sites. Indicator species currently used to measure ecosystem health may not work for all the owls mentioned. Artificial nest sites should not replace an ecosystem's approach to owl management. It's time to create a strong research and management strategy designed to meet the habitat needs of these owls. The National Forests must lead the way.

Two unfortunate examples help illustrate the need for more information. In March 1986, a Boreal Owl nest territory was located in a mature spruce/fir stand west of Missoula. Later that spring a logging company moved into the area and began operations (Holt 1986). While this provides an opportunity to monitor the effect of logging disturbance on the owls, it is doubtful whether the disturbance-related data will be worth the potential loss of the nest territory. In July 1985, north of Missoula, a firewood cutter felled the first documented nest site for Flammulated Owls in Montana (Holt et al., submitted for publication).

In the case of the Boreal Owl, this was a known nest territory, previously surveyed in 1984 and 1985. While the timber in the area had already been sold to a contractor, could not some contract modification been made to protect the nest stand? The answer, of course, is "yes" if the Forest Service had had an owl management strategy or program to rely on. Regarding the Flammulated Owls, at least the woodcutter reported the incident. This raises another significant question which is, are firewood cutting guidelines and dissemination of information adequate to maintain snags along forest roads?

These are standard old-growth questions, which in the immediate past were most often associated with woodpeckers. Beebe (1974) and McClelland (1977) thoroughly address these issues. Further, Fischer and McClelland (1983) list over 1,700 references pertaining to cavity nesting birds.

ACKNOWLEDGMENTS

We thank Al Bratkovich, Jeff Foote, Don Godtel, Steve Gniadek, Guenter Heinz, Willis Heron, Will Kerling, Joe Kipphut, Reed Kuennon, L. Jack Lyon, B. Riley McClelland, Wally Murphy, Tim Ryan, Don Skaar, Marjorie Swanson, Winton Weydemeyer, and P. L. Wright for their personal records and suggestions for survey techniques. We are most grateful to Don Skaar for allowing us to use his father's (P. D. Skaar) personal records.

We also thank Lorna McNay and Carmen O'Leary for typing, editing, and revising the manuscript.

We are especially grateful to Greg and Patricia Hayward for coordinating the 1984 Boreal Owl Surveys in western Montana.

LITERATURE CITED

- American Ornithologists' Union (AOU). 1983. Check-list of North American Birds, 6th edition. American Ornithologists' Union (Washington, D. C.).
- Beebe, S. B. 1974. Relationships between insectivorous hole-nesting birds and forest management. Yale Univ. School of For. and Envir. Studies. New Haven, CT. 49 p.
- Bendire, C. E. 1888. Notes on the habits, nests and eggs of the genus *Glaucidium* Boie. *Auk* 5:366-372 p.
- Boxall, P. C. and P. H. R. Stephney. 1982. The distribution and status of the Barred Owl in Alberta. *Can. Field-Nat.* 96:46-50 p.
- Braly, J. C. 1930. Nesting of the California Pygmy Owl in Oregon. *Condor* 32:304 p.
- Bull, E. L. and R. G. Anderson. 1978. Notes on Flammulated Owls in north-eastern Oregon. *Murrelet* 59:26-27 p.
- Escano, R. 1984. 1984 Boreal Owl survey summary. Wildlife, Fish, and Habitat Relat. Prog., Northern Reg. USFS, Missoula, MT 11 p.
- Fischer, W. C. and B. R. McClelland. 1983. A cavity-nesting bird bibliography including related titles on forest snags, fire, insects, disease, and decay. USDA For. Ser. Gen. Tech. Rep. INT-140 79 p. Intermt. For. and Range Exp. Stn., Ogden, UT 84401.
- Hand, R. L. 1969. A distributional check-list of the birds of western Montana. R. L. Hand, Missoula, MT.
- Hayward, G. D. and E. O. Garton. 1983. First nesting record for Boreal Owl in Idaho. *Condor* 85:501 p.
- Hoffman, R. S., Hand, R. L., and P. L. Wright. 1959. Recent bird records from western Montana. *Condor* 61:147-151 p.
- Holman, F. C. 1926. Nesting of the Pygmy Owl in Yosemite. *Condor* 28:92-93 p.

- Holt, D. W. 1986. 1986 Boreal Owl survey results on the Lolo National Forest, Missoula, Montana, U.S. For. Serv. Intermt. Exp. Stn. Rep., Missoula, Montana 4 p.
- Holt, D. W. and W. D. Norton. 1986. Observations of nesting Northern Pygmy Owls. *Rap. Res.* 20:39-41 p.
- Holt, D. W., J. J. Jonkel, and B. A. McIntosh. Specimen record of a Boreal Owl in Western Montana. In press.
- Holt, D. W., J. A. Hoy, and P. L. Wright. Nest record of Flammulated Owls for Montana. Submitted for publication.
- Linkhart, B. D. 1984. Range, activity, and habitat use by nesting Flammulated Owls in a Colorado ponderosa pine forest. MS thesis. Colorado State Univ., Fort Collins, 45 p.
- Marcot, B. G. 1980. Flammulated Owls in northwestern California. *West. Birds* 11:141-149 p.
- Marks, J. S. 1986. Nest-site characteristics and reproductive success of Long-eared Owls in southwestern Idaho. *Wils. Bull* 98:547-560 p.
- McClelland, B. R. 1977. Relationship between hole-nesting birds, forest snags, and decay in western larch-Douglas-fir forests of the northern Rocky Mountains. Ph.D. diss. Univ. Montana, Missoula, MT 482 p.
- Mikkola, H. 1983. *Owls of Europe*. Buteo Books, Vermillion, S.D.
- Munroe, J. A. 1919. Notes on some birds of Okanagan Valley, British Columbia. *Auk* 36:64-74 p.
- Nero, R. W. 1980. *The Great Gray Owl: Phantom of the Northern Forests*. Smithsonian Inst. Press, Washington, D.C.
- Norton, W. D. and D. W. Holt. 1982. Simultaneous nesting of Northern Pygmy Owls and Northern Saw-whet Owls in the same snag. *Murrelet* 63:94 p.
- Palmer, D. A. and R. A. Ryder. 1986. The first documented breeding of the Boreal Owl in Colorado. *Condor* 86:215-217 p.
- Reynolds, R. T. and B. D. Linkhart. 1984. Methods and materials for capturing and monitoring Flammulated Owls. *Great Basin Nat.* 44:49-51 p.
- Rogers, T. H. 1972. The Nesting Season. *Am. Birds* 26:878-882 p.
- Rogers, T. H. 1975. The Nesting Season. *Am. Birds* 29:1006-1010 p.
- Rogers, T. H. 1976. The Spring Migration. *Am. Birds* 30:865-869 p.
- Rogers, T. H. 1976. The Nesting Season. *Am. Birds* 30:978-982 p.
- Rogers, T. H. 1977. The Nesting Season. *Am. Birds* 31:1162-1166 p.
- Rogers, T. H. 1979. The Nesting Season. *Am. Birds* 33:881-883 p.
- Rogers, T. H. 1982. The Spring Migration. *Am. Birds* 36:875-877 p.
- Saunders, A. A. 1921. A distributional list of the birds of Montana. *Pac. Coast Avifauna* No. 14.
- Shea, D. S. 1974. Barred Owl records in western Montana. *Condor* 76:22 p.
- Skaar, P. D. 1975. *Montana Bird Distribution*. P. D. Skaar, Bozeman, MT.
- Skaar, P. D. 1980. *Montana Bird Distribution*. P. D. Skaar, Bozeman, MT.
- Skaar, D., D. Flath, and L. S. Thompson. 1985. *Montana Bird Distribution*. *Mont. Acad. of Sci. Mono.* 3, 44:1-69 p.
- Taylor, A. L., Jr. and E. D. Forsman. 1976. Recent range extensions of the Barred Owl in western North America. *Condor* 78:560-561 p.
- Webb, B. 1982. Distribution and nesting requirements of Montana forest owls in Colorado. *Colo. Field Ornith. Jour.* 16:76-81 p.
- Weydemeyer, W. W. 1927. Some new birds from western Montana. *Condor* 29:159 p.
- Weydemeyer, W. W. 1932. Some 1931 notes from Lincoln County, MT. *Condor* 34:139 p.
- Winter, J. 1974. The Distribution of the Flammulated Owl in California, 5:25-44 p.
- Wright, P. L. 1976. Further bird records from western Montana. *Condor* 78:418-420 p.
- Youman, C., J. Swenson and S. Knapp. 1981. Preliminary Results of Owl Census in Riparian and Upland Habitats in Southeastern Montana. *In Management of Riparian Ecosystems. Proc. Wildl. Soc., Mont. Chapt. Ann. Meeting*, 64-67 p.

The following tables and appendices for western Montana include: Census Techniques Used (Table 1); Approximate Timeframes and Habitat to Begin Censuses (Table 2); Types of Nests Used and Probably Most Important Trees for Nesting (Table 3); Forest Owl Survey Records (Appendix 1); Roost Site Records (Appendix 2); and Nest Record Sheets (Appendix 3). All sheets can and should be used or modified to meet the needs of the investigator.

TABLE 1

CENSUS TECHNIQUES GUIDELINES FOR WESTERN MONTANA

1. Calling during the nesting season--vocalize or use tape recorder--listen for a few moments before you begin.
2. Initiate calling of the smaller owls first, otherwise calls of the larger owls may intimidate the smaller owls, and they may not respond.
3. Distance between stops is up to the caller, however, a good rule-of-thumb is to use shorter intervals for smaller owls and longer intervals for larger owls.
4. Because routes can run several miles, we suggest calling for approximately 4 to 6 minutes at each stop. Listen 1 to 2 minutes, play the call for 1 minute, listen for 1 to 2 minutes, repeat.

5. Whether you have made contact or not, record your positive/negative success and effort expended on a data sheet. Include species, type of call, date, time, weather, temperature, cloud cover, phase of moon, elevation, habitat, approximate distance to owl, and any other information you wish to include or observations made.
6. At some point back at camp, home, office, be specific about county, drainage, legal description.
7. If nest is found, provide some type of nest record sheet with nest site parameters.
8. Other

TABLE 2

RELATIVE DATES AT WHICH POTENTIALLY BREEDING OWLS SHOULD BE MOST VOCAL IN WESTERN MONTANA

Species	Survey Dates	General Habitat
Flammulated Owl	May-June	Mature Ponderosa Pine
Western Screech Owl	Feb.-Early April	Mature Riparian Areas
Northern Pygmy-Owl	Early April-May	Mixed Douglas-fir
Barred Owl	March-April	Mature Western Larch/Douglas-fir
Great Gray Owl	March-April	Spruce/Fir Bog or Lodgepole Pine/Wet Meadows
Long-Eared Owl	March-April	Mixed Ponderosa Pine/Douglas-fir or Lodgepole Pine
Boreal Owl	Feb.-Early April	Mature Spruce/fir
Saw-Whet Owl	Mid-Feb.-April	Mixed Ponderosa Pine

TABLE 3

TYPE OF NEST SUBSTRATE PROBABLY USED AND PROBABLE MOST IMPORTANT NEST TREES

Owl Species	Nest Site Substrates			Nest Tree
	Cavity	Broken Tops	Stick	
Flammulated Owl	x			Ponderosa Pine/Western Larch
Western Screech-Owl	x			Black Cottonwood/Aspen
Northern Pygmy-Owl	x			Douglas-fir/Ponderosa Pine
Barred Owl	x	x	x	Western Larch
Great Gray Owl		x	x	?
Long-Eared Owl			x	?
Boreal Owl	x			Spruce/Sub-alpine Fir
Saw-Whet Owl	x			Ponderosa Pine/Western Larch

NOTE: Many species may call any time of the year, day, or night. These survey suggestions represent the onset of owl breeding season in western Montana.

APPENDIX 1

FOREST OWL SURVEY RECORDS
IN WESTERN MONTANA

Species _____ No. _____ Date _____

State _____ County _____ Area _____

Legal Description T. __, R. __, Sec. __, 1/4 Sec. __,

1/4 1/4 Sec. __ (if available)

Direction to Site (Landmarks) _____

General Habitat Description (i.e., old-growth spruce/fir greater than 20 ft.) Nest ___Y___N

		Survey Responses/Night:
Moon Phase	_____	Time Start _____
Elevation	_____	Unsolicited Calling _____
Weather	_____	Solicited Response _____
(Cldy, Clear)	_____	Time End _____
Wind (0,1,2,3)	_____	No. Calling Stations _____
Temperature	_____	No. Habitat Surveyed _____
Aspect	_____	Riparian/Deciduous _____
Distance to:		Black Cottonwood BC _____
		Aspen AS _____
		Other _____
Water	_____	Coniferous _____
Road	_____	Douglas-fir DF _____
(highway/	_____	Ponderosa Pine PP _____
logging)		Western Larch WL _____
Meadow	_____	Lodgepole Pine LP _____
Clearcut	_____	Englemann Spruce ES _____
Bog	_____	Subalpine Fir SF _____
Other	_____	Other _____

APPENDIX 2

ROOST SITE RECORDS

Species _____ No. _____

Date _____ Season _____

Legal Description T. __, R. __, Sec. __, 1/4 Sec. __,

1/4 1/4 Sec. __

General Habitat Description _____

Substrate	_____	Distance to:
Substrate Species	_____	Road _____
Roost Height	_____	Water _____
DBH (if)	_____	Habitation _____
Canopy Cover	_____	Open Habitat _____
Slope	_____	
Other:	_____	Other: _____

APPENDIX 3

NEST RECORD SHEET

Species _____ Nest Name _____ Date _____

Nest Located ___Y___N Evidence of Breeding _____

State _____ County _____ Area _____

Legal Description T. __, R. __, Sec. __, 1/4 Sec. __,

1/4 1/4 Sec. __

Nest Substrate:		Nest Variables:
Bare Ground	_____	Substrate Species (if)
Ground	_____	Nest Dimension
Vegetation	_____	Surrounding Vegetation
Shrub/Bush	_____	Height of Nest
Tree (Cavity)	_____	Height of Tree
Tree (Stick)	_____	Height of Cliff
Cliff (Cavity)	_____	Cavity Dimension
Cliff (Ledge)	_____	Burrow Dimension
Cliff (Stick)	_____	Primary Excavator
Burrow	_____	DBH (diameter at
Other	_____	breadth/height)
		Slope
		Canopy
		Aspect
		Other

Distance to:

Road (major, secondary, logging) _____

Water (river, creek, lake, bog) _____

Open Habitat (meadow, clearcut, pasture, grasslands, agriculture) _____

Other: _____

Potential Disturbance Factors _____

Prey Collection Dates _____

Notes _____

Other Information _____

People Power: Help for the Owl Bander¹

C. Stuart Houston²

Abstract.--A large-scale Great Horned Owl banding program in Saskatchewan evolved because of help available each year from: 1) a relatively constant number of interested farmers who have located and directed me to about 1200 active nests; 2) an ever-changing group of young men who have volunteered to help climb trees and band the young.

INTRODUCTION

My owl studies began innocently from random banding of any bird at hand, including 15 Great Horned Owls, *Bubo virginianus*, during my first 15 years of banding. Of two recoveries, one was from Bluffton, Minnesota, 450 miles to the southeast, an unusual movement for a year-round resident. This encouraged me to band more owls (Houston 1978).

My efforts near Yorkton, Saskatchewan, were first aided by Bill Horseman, a 15-year-old trapper and birdwatcher, who located 5 nests in 1958 and 23 in 1959. In 1960, I had a weekly birdwatching program on CKOS Television, to promote the Peterson bird cards in Brooke Bond tea and coffee. Peterson's *Field Guides* were offered to those finding the most owl nests. The results exceeded my expectations when three winning pairs of farm lads found 20, 16 and 10 successful nests, respectively; 150 flightless young were banded that May.

NEST FINDERS

After moving to Saskatoon and completing my training in radiology, I several times placed a request in Doug Gilroy's nature column in the *Western Producer*, a farm newspaper with 160,000 circulation, asking Saskatchewan farmers to notify me of owl nest locations. This produced responses from a select group of observant, interested and helpful farmers, most of whom have been finding nests for me ever since. Schoolteacher Bryan

Isinger stimulated his pupil, Rosemary Nemeth to find owl nests near Yellow Creek. Peter Boychuk and Maurice Mareschal, teachers in the nearby villages of Crystal Springs and Yellow Creek, soon enlisted their students to find owl nests as well. Most of the successful nest finders listen for the location of owls hooting on their land and watch all large nests seen during farm work and local travel in March and April, before the leaves come out. Leif Nordal searches by ski-doo and Ed Brockmeyer on cross-country skis. Permission is obtained from their neighbors before our banding visit. Three farmers have located 100 successful nests and another six have found 40 or more (Table 1).

Table 1.--Great Horned Owl nest finders, 1968-1986

Leif Nordal, Bill Cochrane at Bulyea	111 nests
Pete Hill at Duval	108 nests
Leslie & Rose Nemeth at Yellow Creek	94+ nests ¹
Ian Lochtie at Kelliher	88 nests
Bob Gillard & Shirley Norlin at Wynyard	80 nests
Peter Boychuk at Crystal Springs	61 nests
Bob Robinson at Simpson	52 nests
Maurice Mareschal at Birch Hills	48 nests
Wayne Harris at Raymore	42 nests

¹owls at another six nests banded by Wayne Harris in 1986

TREE CLIMBERS

Volunteers have always been needed to help with climbing trees. To climb 23 trees, many difficult, and band up to 61 nestlings in one day, would surpass the stamina of most men. We like to have three or even four climbers taking turns. This has become increasingly important as my knees and ankles become increasingly arthritic due to wear and tear as I grow older.

¹Paper presented at the symposium, Biology and Conservation of Northern Forest Owls, Feb. 3-7, 1987, Winnipeg, Manitoba. USDA Forest Service General Technical Report RM-142.

²Stuart Houston is Professor of Medical Imaging, University of Saskatchewan, Saskatoon, Sask.

Amazingly, volunteer climbers have always appeared when needed; some years I have had more offers than could be accommodated. Some biology students, at the high school or University level, come because of an interest in birds; although our rule is that we stop only for "lifers", it is a rare weekend when I cannot show them a species new to their life list. Some come with an interest in photography and others for sheer adventure. Some come to meet the nicest farmers in Saskatchewan -- and their daughters! Some have helped me from dawn to dark on every May weekend for several years in succession, while others don't come a second time!

My helpers have included city boys, farm boys and medical doctors. For several years I had physical education students, two of whom were ranked second in Canada for their weight class in wrestling; one of them, John Hanbidge, successfully wrestled with -- and banded -- an adult female Great Horned Owl when she delayed leaving her nest.

COSTS

Owl banding is an expensive proposition for the master bander. Food and transportation are provided for the volunteers, as well as hotel expenses when we overnight. My wife, Mary, fills a large cooler with beef, ham, turkey, and peanut butter-and-raisin sandwiches, cookies and gallons of iced tea. A four-wheel drive vehicle is a necessity. We have travelled as many as 2000 km on a 3-day long weekend, with major expenditures for gas, oil, tires and general wear-and-tear. Direct costs average about ten dollars per nestling owl banded.

In an average year, six female owls in one hundred will puncture the bander with their talons while he is up the nest tree. This necessitates a tetanus booster shot at a nearby hospital. Only once, near Strasbourg on 20 May 1979, did both adult owls attack the bander -- the female scoring eight direct hits and the male two, while John Hanbidge banded two nestlings. Since 1964 we have worn hard hats and safety goggles. Although I've had my goggles punctured and many gashes in my leather jacket (fig. 1), we've had no partial loss of eyesight as was experienced by Dick Lumsden near Edmonton, Alberta (Lumsden 1960). To date no climber has broken any bones.

BENEFITS

Perhaps the process has been more important than the project. My activities have increased public awareness of raptors in general and owls in particular. This has been most evident at Yellow Creek and Crystal Springs, where in the early 1960s the "only good owl was a dead owl", local farmers and their families are now interested in owls, and have developed some understanding of their niche in nature. One year I was the invited

speaker at Crystal Springs high school graduation ceremonies. No one can say how much influence I have had on my young climbers, since some of them had a career in biology in mind before they met me. I do believe that all have a strong conservation ethic and some after a period of decreased outdoor activity, are now instilling this ethic in their children. I follow their careers with interest and take a fatherly pride in their achievements.

I will mention only one nest finder and two climbers specifically. Rosemary Nemeth graduated from a two-year resources technology program and became Saskatchewan's first female conservation officer, before earning a University degree in biology, but her farmer father has continued to locate owl nests every year. Lorne Scott of Indian Head and Wayne Harris of Raymore, high school students when I first visited their owl nests, have gone on to obtain master banding permits of their own. Lorne, the naturalist for the Wascana Park Authority in Regina, has been president of both the Saskatchewan Natural History Society and the Saskatchewan Wildlife Federation and was the first recipient of Canada's annual Roland Michener Conservation Award. Wayne Harris is office manager of the Saskatchewan Natural History Society and with his wife operates an environmental consulting service.

This unplanned project, which grew irresistably, without funding or support of any kind, has added to scientific knowledge. Papers presented or cited at this conference indicate some of the things we have learned concerning longevity and the unexpected southeasterly movements of the Great Horned Owl, as well as its cyclical success, so closely tied to the 10-year cycle of the Snowshoe Hare.

LITERATURE CITED

- Houston, C. Stuart. 1978. Recoveries of Saskatchewan-banded Great Horned Owls. *Canadian Field-Naturalist* 92:61-66.
- Lumsden, Dick. 1960. A plea to banders for caution in handling Great Horned Owls. *Blue Jay* 18(1):18-19.



Capture Techniques for Owls¹

Evelyn L. Bull²

Information on capture techniques for owls--great gray (*Strix nebulosa*), spotted (*S. occidentalis*), boreal (*Aegolius funereus*), northern saw-whet (*A. acadicus*), and western screech (*Otus kennicotti*)--was presented by Gregory D. Hayward, Gary S. Miller, Robert W. Nero, and Evelyn L. Bull.

Hayward used bal-chatris, mist nets, and dip nets on the end of poles to capture three species of small owls. Bal-chatris were effective for capturing boreal and western screech owls, but not for northern saw-whet owls. The double-topped bal-chatri trap had 80 2.5-cm-diameter nooses made of 3-kg-test monofilament line (fig. 1). To trap unmarked boreal owls during the spring, Hayward placed 10 bal-chatri traps near a large mist nest. At dark, a recorded territorial song of the owl was played for 20 min each hour throughout the



Figure 1.--Boreal owl captured on a bal-chatri. Photo by Pat Hayward.

¹Workshop presented at the Northern Forest Owl Symposium, Winnipeg, Manitoba, February 3-7, 1987.

²Research Wildlife Biologist, Forestry and Range Sciences Laboratory, La Grande, OR.

night; traps and mist nets were checked each hour. To recapture radio-tagged owls, a bal-chatri was placed under the roosting owl during the day.

A small mist net, 2.5 m long and 1.5 m tall, was effective for capturing radio-tagged boreal owls (fig. 2). The net was placed in front of the roosting owl in a shaded location, and a mouse was tethered behind the net. When the owl flew into the net, observers standing 1-2 m away immediately captured the bird. Poles supporting the net were light weight fiberglass rods.



Figure 2.--Boreal owl (arrow) in a mist net with a mouse tethered on the left side of the net between 2 upright sticks. Photo by Greg Hayward.

Hayward captured boreal, northern saw-whet, and western screech owls from their day roosts, with a dip net on a 5.5-m fiberglass extension pole. The oval hoop frame was 70 cm long and 45 cm wide; the net was made of mist net material. Hayward found that a slow steady approach to the owl was more effective than a fast one. If two people were available, one could distract the owl while the other worked the net up toward it.

To capture spotted owls, Miller used a noose-pole, a 6-m long, telescoping fiberglass pole with a noose made of a flexible 2-mm-diameter plastic cord. The owls were located by calls. When a bird was sighted, a tethered deer mouse (*Peromyscus maniculatus*) was used to lure the owl close enough to put the noose over its head and tighten it around the neck. The owl was quickly lowered to the ground. Two split rings, tied 95 mm apart, kept the noose from choking the owl. Other techniques used to trap spotted owls included mist nets, bow nets, bal-chatri traps, and dip nets.

Nero had excellent success trapping great gray owls in Manitoba during the winter with a casting rod and fishing net (fig. 3). A simulated mouse lure on the end of the line was cast onto the snow within sight of the owl (figs. 4 and 5). The lure was reeled past a second person who netted the owl as it flew after the mouse. The technique worked well for hungry owls that had not been previously caught by this method.



Figure 3.--Fishing rod and net used to capture great gray owls. Photo by B. Ratcliff.

Nero also used a verbaill to capture great gray owls. A live mouse in a cage was placed on the snow, and the verbaill, mounted on top of a post, was set upright to act as a perch. When the owl landed on the post, its legs were caught in the noose.

I have used five techniques to capture adult great gray owls during the nesting season, including bal-chatris, mist nets, net-guns, noose poles, and a trap operating on the same principle as a verbaill. Bal-chatris were most effective for birds that had never

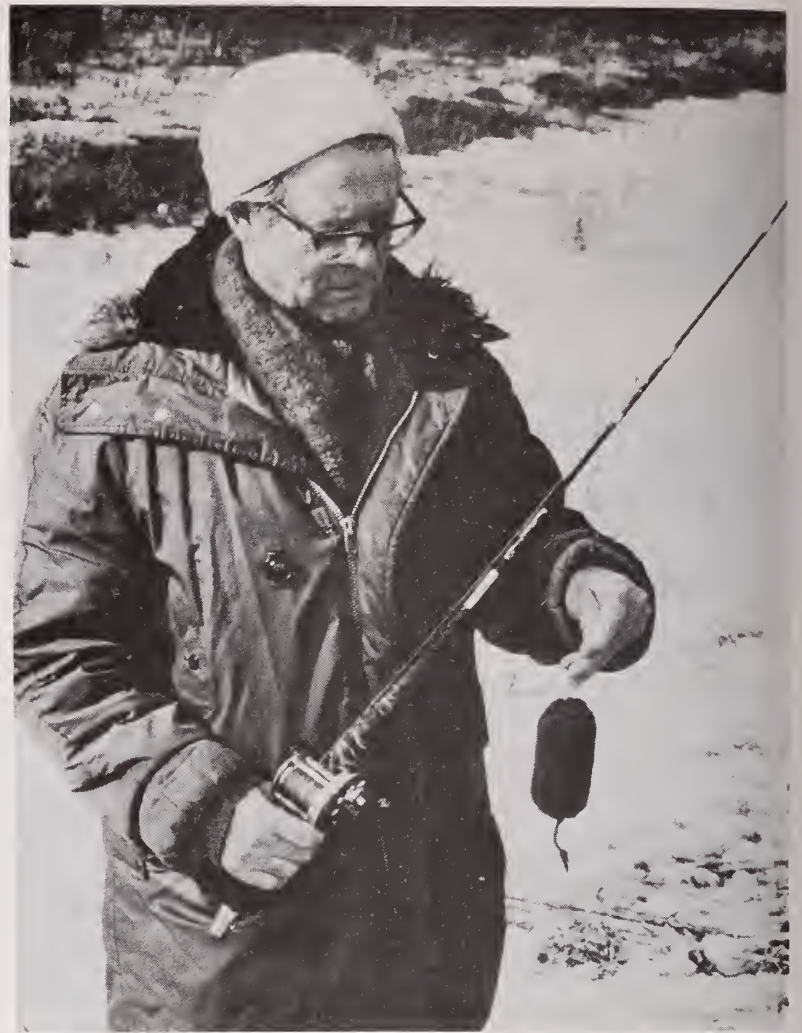

Figure 4.--Robert Nero with mouse lure used to capture great gray owls. Photo by H. W. R. Copland.

been trapped before (fig. 6). Two gerbils (*Gerbillus* sp.) were used for bait, and nooses were made from 18-kg-test monofilament line.

Mist nets were used with various forms of bait including gerbils, juvenile birds, common ravens (*Corvus corax*), or great horned owls (*Bubo virginianus*) (fig. 7). In several cases, mist nets were suspended at least 15 m above the ground near the nest to capture the male owl when he delivered prey.

A noose-pole, similar to that described by Miller, was used to capture female great gray owls after the young had fledged and were handled. The females were very aggressive at this time and were easily noosed.

The net-gun was used to capture birds that could not be caught by any other method. It was only used to capture owls when they were perched low to the ground or were readily accessible from the ground. The net wrapped around the bird and the branch it was sitting on (fig. 7).

Many owls were caught on a trap designed to tighten a noose around the bird's legs when it landed on a tethered gerbil (fig. 8). The advantage of this method was that birds that



Figure 5.--Great gray owl descending on mouse lure. Photo by Robert R. Taylor.



Figure 6. Great gray owl caught on a bal-chatri; gerbils were used as bait. Photo by Evelyn Bull.



Figure 7. Great gray owl caught in a net shot from a net-gun. Photo by Evelyn Bull.



Figure 8. Trap designed to catch the owl by a noose that tightens around its legs when it lands on prey. Photo by Evelyn Bull.

did not get caught in the noose took the gerbil anyway and did not become trap-shy.

In summary, many techniques have been designed to capture a variety of owls. Some species become trap-shy after a single experience, even if they are not captured. Different techniques are suited to different species because of differences in their behavior and habitat. Ease of trapping can vary by region because availability of prey differs; hungry birds are generally easier to trap than satiated ones.

Owl Telemetry Techniques¹

Thomas H. Nicholls² and Mark R. Fuller³

Abstract.--Successful radio-tracking techniques have been developed for many species of forest owls. These techniques have provided data about movements and behavior that could not be obtained in any other way. The objective of the telemetry workshop was to discuss various radio-tracking methods and to provide participants with telemetry references and a list of suppliers.

INTRODUCTION

Radio-tracking is a relatively new, revolutionary technique for studying the ecology of free-ranging animals. The history of wildlife radio-tracking spans about 25 years. The invention of small transistors and powerful batteries made it possible to build transmitters small enough to be carried by many species of animals (fig. 1). This technology allowed wildlife biologists and electronic experts to develop radio-tracking techniques to determine the precise location of individual animals. Portable radio receiving units enables a researcher to locate and then observe animals frequently (fig. 2).

The most common applications of radio-telemetry are to obtain information on the natural movements and behavior patterns of individual animals. Specifically, applications include the estimation of home range, habitat use, predator-prey relationships, survival, activity periods, effects of weather and other factors on activity, daily and seasonal movement patterns, dispersal and migration patterns, and social relationships, such as territoriality (Nicholls and Fuller; this symposium). Telemetry also can be used to locate nests and roosts either from the ground or air (Nicholls et al. 1981). In addition, bio-telemetry can be used for measuring physiological processes of free-ranging animals (Kuechle et al. in press) (fig. 3).

¹Telemetry techniques workshop presented at the symposium, Biology and Conservation of Northern Forest Owls, Feb. 3-7, 1987, Winnipeg, Manitoba. USDA Forest Service, General Technical Report RM-142.

²Thomas H. Nicholls, Project Leader, Wildlife Habitat Research, United States Department of Agriculture, Forest Service, North Central Forest Experiment Station, 1992 Folwell Avenue, St. Paul, Minnesota 55108, USA.

³Mark R. Fuller, Ecologist, Patuxent Wildlife Research Center, Laurel, Maryland 20708, USA.

EARLY DEVELOPMENT OF OWL RADIO-TRACKING TECHNIQUES

Workshop participants viewed a film depicting the development of owl tracking with a semi-automatic system for monitoring animal movements on the University of Minnesota's Cedar Creek Natural History Area (CCNHA) 30 miles north of Minneapolis, Minnesota USA (Cochran et al. 1965). The system was primarily designed and put together by William Cochran, who many agree has contributed more to the field of wildlife telemetry than any other single person. The system utilized two towers 1/2 mile apart (70 ft and 100 ft high) each with directional receiving antennas (fig. 4). The antennas rotated every 45 seconds and, under ideal conditions obtained 1,920 locations per animal every 24 hrs for up to 52 animals simultaneously. Received signals were displayed by indicator lights, then photographically recorded. The film was read at selected intervals to obtain degree bearings from

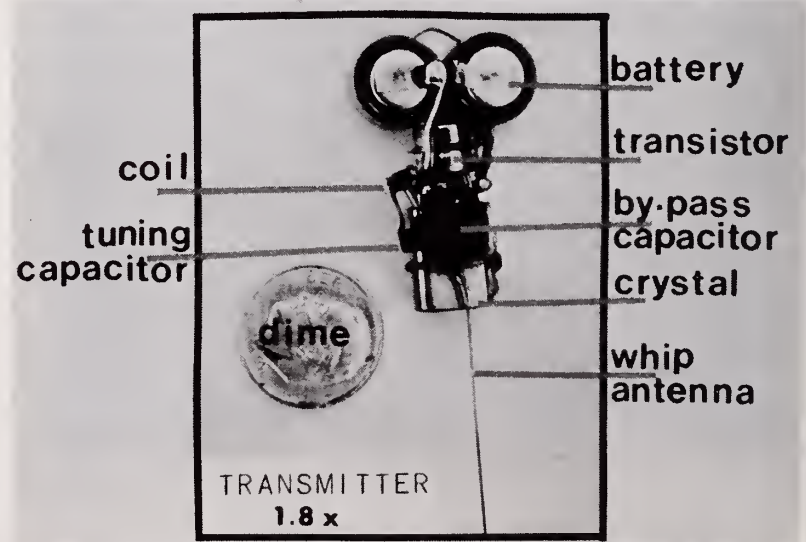

Figure 1.--Components of a 5 gram radio transmitter.



Figure 2.--Portable receiving units can be used with different antenna systems, such as the loop antenna (top) and Yagi antenna (bottom), to locate and observe owls under field conditions.

each tower. These data, time, and date were entered in a computer and programs calculated animal locations and plotted them on a map of the CCNHA (fig. 5). The resulting information was used for ecological studies of many species including owls (Nicholls and Warner 1972) (fig. 6). Techniques and equipment developed at the CCNHA are now in world-wide use for research on many species of animals.

Radio-tracking techniques for owls were developed for three species of owls using the CCNHA radio-tracking system: the great horned owl (*Bubo virginianus*), the barred owl (*Strix varia*) (Nicholls and Warner 1968) (figs. 7 and 8), and the northern saw-whet owl (*Aegolius acadicus*) (Forbes and Warner 1974) (fig. 9). These studies paved the way for other raptor telemetry because the technique was shown to have little influence on the natural behavior of radio-tagged birds. Since the 1960's, radio transmitters and attachment techniques have been improved and

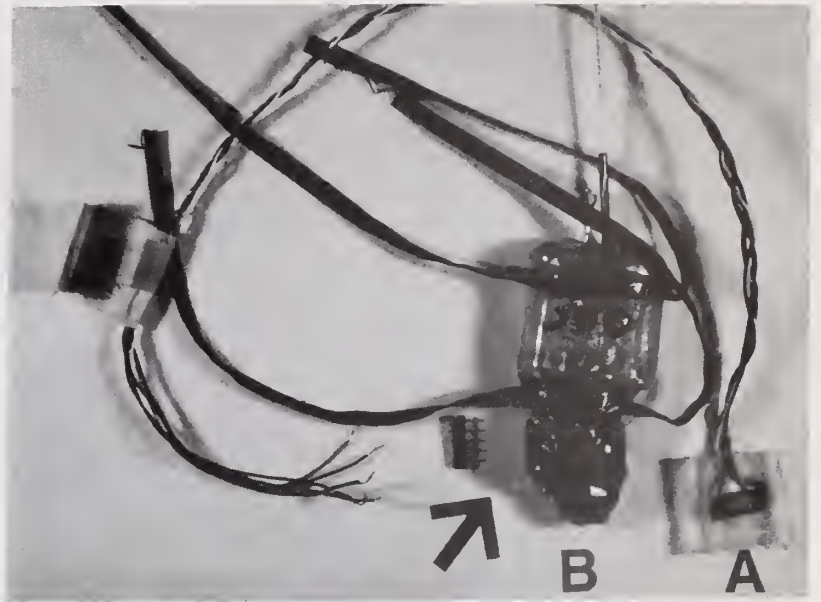

Figure 3.--A radio transmitter used to study gastric motility in barred owls. The gastric sensor (A) is surgically implanted and plugged into (arrow) a back-pack transmitter (B) that transmits an owl's location and gastric activity.



Figure 4.--(A) A 100 foot radio-tracking tower located on the CCNHA. (B) Each owl was assigned a different radio frequency and a receiver was tuned in to each of two radio-tracking towers. All owls with transmitters could be monitored simultaneously.

refined (Dunstan 1972, Amlaner and Macdonald 1980, Cochran 1980, Kenward 1985). For example, Evelyn Bull (personal communication) put radio transmitters on 58 great gray owls (*S. nebulosa*) from 1983 to 1986. Transmitters weighing about 22 grams transmitted for at least 1 year at which time they were replaced. The transmitter with whip antenna was put on the back of a bird with a tubular teflon ribbon back-pack harness in a figure eight type of configuration. Some birds carried them 3 years, and none showed any abrasions or apparent ill effects from the transmitters. Transmitters built today are more reliable, smaller, lighter, more durable and are economical, considering the amount of information that can be gained and that some data cannot be obtained in any other way.



Figure 7.--The first radio transmitter harnesses placed on great horned and barred owls in the early 1960's weighed 70 to 90 grams and transmitted up to 200 days with signals detected for up to 3 miles by the CCNHA radio-tracking towers. Since then, refinements and new technology allow transmitters to be much smaller, lighter, and more reliable.

OWL TELEMETRY CONSIDERATIONS

Radio telemetry is an excellent tool for studying nocturnal birds such as owls. Many results reported in this symposium were obtained using radio-tracking to obtain data. The following summarizes some of the important considerations when using telemetry to study owls.

Transmitter attachment techniques are as diverse as the size, shape, weight, and application of the transmitters. Before trying new methods and equipment, it is advisable to check with researchers experienced with similar techniques and species. When using telemetry for the first time or developing new methods, work with captive birds in suitable flight cages to identify negative effects that transmitter attachments might have. Observations of takeoff, flight, landing, attacking, capturing, killing, and eating prey, etc. should be made to make sure that transmitters do not interfere with behavior (fig. 10). Kay McKeever, Owl Rehabilitation Research Foundation, RR #1, Vineland Station, Ontario LOR 2E0, offered use of her facilities to test radio transmitters on owls.

Before beginning a radio-tracking study, determine for how long and how far signals must be received from the owls. Large, heavy batteries provide more power for longer life or stronger radio signals. Consider compromising between

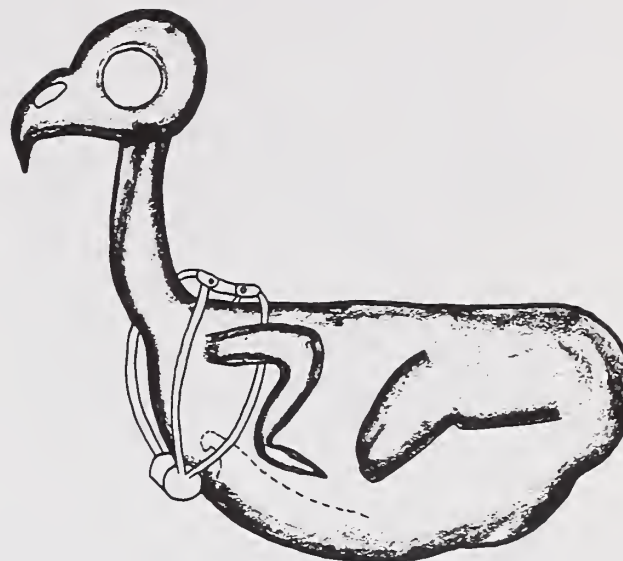

Figure 8.--Position of the first transmitter harness (fig. 7) developed in the early 1960's as it appeared on the body of an owl without feathers.

signal strength, life, and weight. Make sure the company supplying the equipment understands your needs and has experience with similar applications. Remember that design engineers usually provide optimistic estimates of transmitter life that might not be met under variable field conditions, especially low temperatures. The duration of the study can also determine attachment techniques. Many harness materials last for months or years and can only be removed after recapturing the owl. Recapture is often difficult, expensive, and time consuming. Presently, there are no reliable methods for detachment at pre-determined durations; however, some "drop off" harness attachments have been developed (Boshoff et al. 1984, Karl and Clout 1987).

Tail mounts must be used with light-weight transmitters, and are lost when the feathers are moulted (Fitzner and Fitzner 1977, Kenward 1985) (fig. 11). We suggest that the transmitter supported by a single rectrix be no more than 2% of the owl's body weight because tail-mounted transmitters may stimulate the tail feathers to moult prematurely. Back-pack transmitters require suitable harness material; teflon ribbon and coated, flexible wire have been useful on owls (Dunstan 1972, Smith and Gilbert 1981). Glued-on transmitters (Raim 1978) have not been used often on owls. Solar-powered transmitters are lightweight and can be used alone or with rechargeable batteries to provide nighttime coverage. Solar transmitters must be attached so the birds cannot preen the transmitter under the feathers. Dense vegetation will inhibit or reduce the effectiveness of solar-powered transmitters.

Recent articles by Caccamise and Hedin (1985) and Pennycuick and Fuller (in press) deal with bird size and the potential effects of transmitter weight. In general, transmitter weight should be a smaller percentage of the body weight for large birds than for small birds. Transmitter weight can affect potential maximum velocity, maximum power, endurance, and maneuverability of birds. After a transmitter is attached, an owl might reduce its activity for a few days as it adjusts to the harness and transmitter (Nicholls 1973).

In the United States, biologists need a frequency authorization or license from the Federal Communications Commission to conduct telemetry studies. There are severe restrictions on frequency, power output, numbers of transmitters per unit area, etc. (Kolz 1983). The U.S. Fish and Wildlife Service Bird Banding Laboratory, Laurel, MD 20708 USA, provides brief information about the regulations. In addition, there are regulations that must be followed while using aircraft to radio-track animals. Safety is of prime consideration. Placement of antennas on aircraft must conform to certain standards and should be checked by an expert. One workshop participant told of a potentially serious situation in which an aircraft flew into clouds where icing developed, breaking off an antenna element that could have caused an accident. Use an experienced pilot who concentrates on flying while the biologist concentrates on animal



Figure 9.--A back-pack radio transmitter with a whip antenna was originally developed for use on northern saw-whet owls and subsequently used on many other species.



Figure 10.--Captive great horned owls wearing radio transmitters were studied in flight cages 3 months to make sure that transmitters did not affect the birds' natural activities. Similar studies should be done on owl species for which telemetry techniques have not been perfected.

tracking. Pilot error has caused most accidents related to aerial radio-tracking. Aerial tracking in mountainous areas can be extremely dangerous. Listening to radio signals for extended periods over the background noise of a plane can cause hearing loss. Biologists should use visual indicators on radio receivers as much as possible during prolonged aerial tracking. Gilmer et al. (1981) and Mech (1983) provide excellent advice for those who need to use aerial radio-tracking.

Braun Hill and Clayton (1985) review nocturnal observation techniques. A potentially useful technique for use on owls is the betalight. Betalights are self-contained, sealed

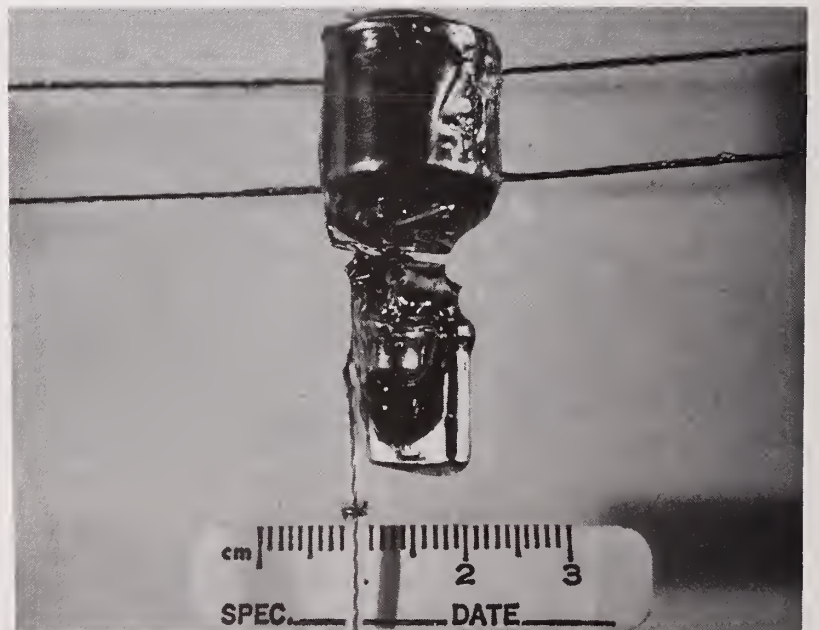

Figure 11.--A light-weight radio transmitter used for owl tail mounts.

glass capsules filled with tritium gas and internally coated with phosphor. The tritium, which is radioactive, emits low-energy beta particles that strike the phosphor coating, causing it to emit a continuous, visible glow. Gregory Hayward (personal communication) tested betalights in conjunction with radio telemetry to make observations of foraging boreal owls (A. funereus). Owls fitted with betalights attached to backpack-mounted radio transmitters were only slightly easier to observe than radio-marked owls without betalights observed with night vision goggles. However, a betalight attached to a radio antenna (fig. 12) so it is held free from an owl's plumage may have great potential, but more testing is needed.



Figure 12.--A betalight (arrow) attached to a radio antenna on a transmitter carried by a boreal owl.

Unless you are electronically inclined, don't try to build your own equipment. When all of the advantages and disadvantages of buying or making radio transmitters and receiving equipment are considered, most participants concluded that it is better to buy equipment from experienced companies than it is to make it themselves.

CONCLUSION

Radio telemetry has contributed to major advances in the study of owl behavior and ecology. Biotelemetry will make more significant contributions as new technology is developed and applied. Spatial requirements and habitat use by various owl species are two important factors that must be determined for effective conservation and management of viable populations of northern forest owls. Radio telemetry helps provide this information.

ACKNOWLEDGMENTS

The authors would like to thank the workshop participants for sharing their owl radio-tracking experiences. We would also like to thank G.D. Hayward for fig. 12 and M. Nelson for reviewing the manuscript.

LITERATURE CITED AND REFERENCES

This list of references is not complete, but it provides a starting point for individuals interested in radio telemetry for owl studies.

- Amlaner, C.J., Jr., and D.W. Macdonald, eds. 1980. A handbook on biotelemetry and radio tracking. Proceedings of an international conference on telemetry and radio tracking in biology and medicine. Pergamon Press, New York, New York. 804 p.
- Boshoff, A.F., A.S. Robertson, and P.M. Norton. 1984. A radio-tracking study of an adult Cape griffon vulture Gyps coprotheres in south-western Cape Province. South African Journal of Wildlife Research 14:73-78.
- Braun Hill, S., and D.H. Clayton. 1985. Wildlife after dark: a review of nocturnal observation techniques. James Ford Bell Museum of Natural History. Occasional Paper 17. 22 p.
- Caccamise, D.F., and R.S. Hedin. 1985. An aerodynamic basis for selecting transmitter loads for birds. Wilson Bulletin 97:306-318.
- Cheeseman, C.L., and R.B. Mitson, eds. 1982. Telemetric studies of vertebrates. Proceedings Symposium of the Zoological Society London No. 49. Academic Press. 368 p.
- Cochran, W.W. 1980. Wildlife telemetry. p. 507-520. In S.D. Schemnitz, ed. Wildlife management techniques manual, 4th edition. Wildlife Society, Washington, District of Columbia (lists references for attachment techniques.)
- Cochran, W.W., D.W. Warner, J.R. Tester, and V.C. Kuechle. 1965. Automatic radio-tracking system for monitoring animal movements. BioScience 15:98-100.
- Dunstan, T.C. 1972. Radio-tagging falconiform and strigiform birds. Raptor Research 6:93-102.
- Fitzner, R.E., and J.N. Fitzner. 1977. A hot melt glue technique for attaching radiotransmitter tail packages to raptorial birds. North American Bird Bander 2:56-57.
- Forbes J.E., and D.W. Warner. 1974. Behavior of radio-tagged saw-whet owl. Auk 91:783-795.
- Forsman, E.D., E.C. Meslow, and H.M. Wight. 1984. Distribution and biology of the spotted owl in Oregon. Wildlife Monograph 87. 64 p.
- Fuller, M.R. 1979. Spatiotemporal ecology of four species of sympatric raptor species. Ph.D. Thesis, 220 p. University of Minnesota.

- Fuller, M.R., T.H. Nicholls, and J.R. Tester. 1974. Raptor conservation and management applications of bio-telemetry studies from Cedar Creek Natural History Area. p. 33-44. In Hammerstrom, Jr., F.N., B.E. Harrell, and R.R. Olendorff, eds. Management of Raptors. Raptor Research Foundation.
- Geissler, P.G., and M.R. Fuller. 1985. Detecting and displaying the structure of an animal's home range. p. 373-378. Statistical Computing Section. Proceedings of American Statistical Association. Washington, District of Columbia.
- Gilmer, D.S., L.M. Cowardin, R.L. Duval, L.M. Mechlin, C.W. Shaiffer, and V.B. Kuechle. 1981. Procedures for the use of aircraft in wildlife biotelemetry studies. USDI Fish and Wildlife Service Resource Publication 140. 19 p.
- Hayward, G.D. A method for study of owl foraging habitat and behavior. Journal of Raptor Research. In review.
- Karl, B.J., and M.N. Clout. 1987. An improved radio transmitter harness with a weak link to prevent snagging. Journal Field Ornithology 58:73-77.
- Kenward, R. 1985. Raptor radio-tracking and telemetry. p. 409-420. In I. Newton and R.D. Chancellor, eds. Conservation Studies on Raptors. International Council for Bird Preservation Technical Publication No. 5. Cambridge, United Kingdom. 482 p.
- Kenward, R. 1987. Wildlife radio-tagging: equipment, field techniques and data analysis. Academic Press. London, England and Orlando, Florida. 200 p.
- Kolz, A.L. 1983. Radio frequency assignments for wildlife telemetry: a review of the regulations. Wildlife Society Bulletin 11:56-59.
- Kuechle, V.B., M.R. Fuller, R.A. Reichle, R.J. Schuster, and G.E. Duke. Telemetry of gastric motility data from owls. Proceedings 9th International Symposium on Biotelemetry. In press.
- Mech, L.D. 1983. Handbook of animal radio-tracking. University of Minnesota Press, Minneapolis, Minnesota. 107 p.
- Nicholls, T.H. 1973. Ecology of barred owls as determined by an automatic radio-tracking system. Ph.D. Thesis, 163 p. University of Minnesota.
- Nicholls, T.H., and D.W. Warner. 1968. A harness for attaching radio transmitters to large owls. Bird Banding 39(2):204-214.
- Nicholls, T.H., and D.W. Warner. 1972. Barred owl habitat use as determined by radio-telemetry. Journal of Wildlife Management 36(2):213-224.
- Nicholls, T.H., M.E. Ostry, and M.R. Fuller. 1981. Marking ground targets with radio transmitters dropped from aircraft. USDA Forest Service, North Central Forest Experiment Station, Research Note NC-274. 4 p.
- Nilsson, J.N. 1978. Hunting in flight by tawny owls (Strix aluco). Ibis 120:528-531.
- Patric, E.F., G.A. Shaughnessy, and G.B. Will. 1982. A bibliography of wildlife telemetry and radio tracking. Department of Forest and Wildlife Management, College of Resource Development, University of Rhode Island, Contribution No. 2054. Rhode Island Agricultural Experiment Station, University of Rhode Island, Rhode Island 02881. 66 p.
- Pennycuik C.J., and M.R. Fuller. Consideration of effects of radio-transmitters on bird flight. Proceedings 9th International Symposium on Biotelemetry. In press.
- Peterson, L. 1979. Ecology of great horned owls and red-tailed hawks in southeastern Wisconsin. Wisconsin Department of Natural Resources Technical Bulletin 111. 63 p.
- Raim, A. 1978. A radio transmitter attachment for small passerine birds. Bird-Banding 49:326-332.
- Shaffer, P.P., and S.M. Ehlers, eds. 1979. Owls of the West; their ecology and conservation. Proceedings National Audubon Symposium. National Audubon Society Western Educational Center, Tiburon, California. 97 p.

SUPPLIERS OF TELEMETRY MATERIALS

The use of firm or corporation names in the following list is solely for the information of the reader. This list is by no means exhaustive and does not constitute an official recommendation or endorsement of any products or services to the exclusion of those offered by other companies.

Advanced Telemetry Systems, Inc.
470 First Avenue North
Box 398
Isanti, Minnesota 55040
612-444-9267

Austec Electronics Ltd.
#1006, 11025-82 Ave.
Edmonton, Alberta, Canada T6G 0T1
403-432-1878

AVM Instrument Co., Ltd.
2368 Research Drive
Livermore, California 94550
415-449-2286

Bally Ribbon Mills
23 N. 7th St.
Bally, Pennsylvania 19503
215-845-2211
(For teflon ribbon harness material)

Beacon Products Co.
360 East 4500 South
Salt Lake City, Utah 84107
801-265-9687

Biotrack
Stoborough Croft
Grange Road, Stoborough
Wareham, Dorset BH20 5AJ
England

B&R Ingenieurgesellschaft mbH
Johann-Schill-Str. 22
7806 March-Buchheim, West Germany

Custom Electronics of Urbana, Inc.
2009 Silver CT. West
Urbana, Illinois 61801
217-344-3460

Custom Telemetry & Consulting
185 Longview Drive
Athens, Georgia 30605
404-548-1024

Holohil Systems Ltd.
RR #2
Woodlawn, Ontario, Canada KOA 3M0
613-832-3649

L.L. Electronics
P.O. Box 247
Mahomet, Illinois 61853
215-586-2132

Lotek Engineering Inc.
11 Younge St. S.
Aurora, Ontario, Canada L4G 1L8
416-727-0181

Microwave Telemetry
610 Chestnut Ave.
Towson, Maryland 21204

Midwest Telemetry
Judy Montgomery
P.O. Box 773
Urbana, Illinois 61801
217-367-1904

Narco Scientific
(Short Range Bio-Medical)
7651 Airport Blvd.
P.O. Box 12511
Houston, Texas 77017
713-644-7521

Remote Monitoring Systems
P.O. Box 2155
Walla Walla, Washington 99362
509-529-1060

Scien-O-Tech Consultants Ltd.
Box 14426 Box 87054
Nairobi Mombasa Kenya

J. Stuart Enterprises
P.O. Box 310
Grass Valley, California 95945
916-273-9188

Telemetry Systems, Inc.
11065 N. Lake View Dr.
P.O. Box 187
Mequon, Wisconsin 53092
Owner - Owen Royce
414-241-8335

Telonics
932 Impala Ave.
Mesa, Arizona 85204-6699
Owner - Dave W. Beaty
602-892-4444

Wildlife Materials Inc.
R.R. 1
Carbondale, Illinois 62901
Wildlife Consultant - R.E. Hawkins
618-549-6330

Owl Management Techniques¹

Katherine V. Haws²

Wildlife management issues and programs involving northern owls were the subject of this workshop. Programs currently underway in various parts of the United States and Europe were summarized by the panelists.

Management for northern owls in the Pacific Northwest has centered around endangered species concerns, primarily the spotted owl. The U.S. Forest Service and conservationists have been embroiled in a decade long controversy involving the spotted owl as an indicator species of old growth fir spruce and hemlock forests. These forests have almost all been cut, and yet studies by ornithologists on the Spotted Owl Recovery Committee have recommended that old growth forest tracts of 1400-4500 acres in size be set aside for each pair of owls. A recommended owl population size for the region is 1500 pairs.

Management plans and actions for several forests in this region have not complied with these requests for habitat protection, and the result has been an embittered conflict between many factions.

Elsewhere in the northwest, the boreal owl has received priority as a candidate species for research. The effects of alternative logging practices, sale sizes and sale distribution on boreal owl populations is being studied in Idaho. Nest boxes are being erected for this species and other cavity nesting species on Idaho's National Forests.

¹ Summary of workshop comments at the symposium, Biology and Conservation of Northern Forest Owls, Feb. 3-7, 1987, Winnipeg, Manitoba. USDA Forest Service General Technical Report RM-142.

² Nongame Specialist, Minnesota Department of Natural Resources, Bemidji, MN. Other workshop panel members were: Thomas Hamer, Ronald Ryder, Harriet Allen, and Geir Sonerud.

The flammulated owl has been the focus of research and management for northern owls in the Rocky Mountain States. Census/survey efforts, and nest box placement have also been initiated on several National Forests in this region.

In Manitoba, an agreement between a paper/wood corporation and the Manitoba Department of Natural Resources² has been signed which sets aside a 12 mi.² area for owl habitat preservation. Great gray owl research receives high priority within the Manitoba Nongame Program, and has received wide backing from many sources, including World Wildlife Fund.

Management programs for the great gray owl in Manitoba have included placement of artificial nest structures and creating habitat reserves.

In the midwest states several northern owls have been placed on state endangered species lists, including the short-eared owl.

Management projects have included basic census and survey projects, as well as placement of nest structures for barred owls and great gray owls. These two species have been selected as indicator species by the U.S. Forest Service-Chippewa National Forest, and management is yet in the planning stages.

Between 5-15% of the timber resources on the Chippewa National Forest have been set aside on an old growth rotation, resulting in habitat protection for northern owls inhabiting these community types.

In Minnesota, the Nongame Wildlife Program of the Department of Natural Resources has initiated several management projects. A publication entitled "Woodworking for Wildlife" describes how to build many nest boxes, including nest boxes for barred owls, great gray owls, and great horned owls. This publication has been made available to the public and as a result, many nest structures have been put up.

Forest management guidelines which consider the needs of wildlife have been completed, and these guidelines address issues such as protection of riparian areas, and snag trees.

A management plan for the Roseau Bog Owl Management Unit in Roseau County, Minnesota has been completed. This management plan addresses needs of, among other wildlife species, the great gray owl on the 14 mi.² unit, and makes recommendations to harvest timber without adversely affecting owl populations in the area.

Currently, most state and federal agencies are at the point of obtaining basic habitat, range and population data for our northern owl species. Until these base-

line data are obtained, management programs cannot be effectively initiated. At this time it is difficult to predict specific impacts of forest management activities such as clear cutting, chemical release, and other silvicultural practices on particular species.

In future years, research will most likely become more applied in scope, in order to answer some of these questions.

Currently, management programs involve habitat preservation, placement of nest structures, protection of nest trees, education efforts, old growth forest protection and initiation of an ecosystem approach to habitat management.

Owl Census Techniques¹

Dwight G. Smith²

General Census Considerations Dwight G. Smith and Tom Carpenter³

Owls are notoriously difficult to count; most species are wholly nocturnal, and roost in concealed locations during daylight. Consequently, methods for estimating the size of owl populations are not well developed. Indeed, of several recent reviews of methods for estimating animal populations, only Ralph and Scott (1981) include chapters on censusing nocturnal birds.

Techniques used to detect and count owls differ considerably in methods of collection, analysis, and presentation of data. There is an urgent need to determine and standardize the method or combination of methods which provides the most accurate counts for each species.

Methods for detecting and counting raptors are summarized by Fuller and Mosher (1981). Owl census techniques include visual searches on foot, tallying numbers of owls singing spontaneously, locating roosts and nests by passerine behavior, and using tape recorded song to elicit responses.

Prior to the advent of readily available portable tape recorders and telemetry equipment, most censuses of owls were conducted by foot or vehicle searches (Craighead and Craighead 1956; Orions and Kuhlman 1957, Hagar 1957, Smith and Murphy 1973). These searches involved intensively looking for owl roost or nest sites, flushing the owl or finding evidence of owl presence such as kills, owl feathers or pellets. The success depended greatly on conspicuousness of the owls and observer acumen. Searches work best with larger species in woodland habitat or snowy owls (*Nyctea scandiaca*) in open habitat. For woodland species, at least, foot searches are generally marginally accurate and time consuming.

Another owl census technique involves the use of listening stations at which observers count spontaneously singing owls. This technique is equivalent to the call counts used by wildlife biologist to census a variety of game birds. Baumgartner (1939) estimated nesting territories

of great horned owls in riparian woodlands along the Missouri River by noting presence of singing pairs, while Miller (1930) augmented spontaneous song with vocal imitations to investigate the territoriality in great horned owls. In Sweden, Holmgren (1979) counted singing Tengmalm's owls (*Aegolius funereus*) along a point transect. Counts of singing owls depend on seasonal song activity, which may vary considerably in timing and frequency for different owl species. Additionally, males lacking territories and females of some owl species may not spontaneously sing, so censusing results will be distorted.

McPherson and Brown (1981) used playback of tape recorded song during daylight hours to locate roost or nest sites of screech owls that responded and also to elicit mobbing behavior of passerines, which oriented to the owl's location. They were able to consistently obtain screech owl locations in their North Carolina piedmont study area.

Eastern Screech Owl responding vocally and visually to playback of tape-recorded song.

Photo by A. Devine



¹Workshop held at the symposium, Biology and Conservation of Northern Forest Owls, Winnipeg, Manitoba, Canada, February 3-7, 1987.

²Dwight G. Smith is Professor of Biology, Southern Connecticut State University, New Haven, CT 06515.

³Thomas W. Carpenter is with Whitefish Point Bird Observatory, Wayne, MI 49184

Recently, playback of tape recorded song has been used to census a variety of avian populations (see Ralph and Scott, 1981). Johnson et al., (1981) noted usefulness of this technique especially for secretive, nocturnal birds, including owls, that cannot otherwise be reliably censused. This technique is based on the territorial behavior of owls; song playback or vocal imitations within their territory will produce a vocal or visual response by the owl attempting to defend its territory against the "intruder." Song playback has been used to survey a number of owl species and has proven most useful in extensively wooded habitat and rugged terrain.

Field Techniques

Methods chosen to count owls should vary with the activity patterns and behaviors of the owl species being censused. Spacing of listening stations, song playback stations, or amount of area searched on foot should be determined by the distance a species will respond to playback, distance the song can be heard, and the territorial size; an individual owl may be counted at two or more stations spaced too close, while some territories might be missed if stations are too far apart. If time and equipment permit, average territory size may be determined using radio-marked owls.

The role of vocalization and associated behaviors in establishing and defending an owl's territory must be considered when using song playback. Most species of owls have a varied repertoire of songs and other vocalizations; some may be more effective in eliciting responses. For example, eastern screech owls show distinct seasonality of warble and whinny song (Smith et al. this proceedings) while Johnson et al., (1981) found that vocalizations of a caged female were effective in obtaining responses by western screech owls (Otus kennicotti) in southern Arizona.

Songs of most North American owls are available on record or tape cassette (e.g., Field Guide to Bird Songs and Field Guide to Western Bird Songs) which are available from Cornell Laboratory of Ornithology. Jon Winters (pers. commun.) is currently preparing a record set of the vocalizations of all North American owls. For maximum effectiveness, we recommend that songs be obtained by directly recording singing owls. This will ensure correct intervals between song and silent periods, and also incorporate any local song dialects.

Speakers should be omnidirectional and placed away from the observers/listeners to increase chances of hearing the sometimes brief responses. Some observers prefer to walk in a circle 30 or more meters around the speaker but we do not recommend this procedure for all owls; individuals that approach before responding may be frightened, similarly, individuals that approach but do not respond also may not be detected.

At least four types of responses by owls have been noted: (1) the owl sings from a distance but

does not approach the song playback station, (2) the owl initially sings from a distance then approaches the song playback station and sings again, (3) the owl silently approaches the playback station, and begins to sing and (4) the owl silently approaches the song playback station but does not vocalize.

Factors Affecting Responses

Vocalization and other responses to song playback may vary with time, weather conditions, moon phase, and background noise. How these factors singly or in combination influence the response of owl species must be determined to effectively evaluate census results.

Four temporal factors which may influence response frequency and type of response for species of owls include time of night, hours after sunset or hours before sunset, and season. Many species have distinct peaks of activity for 2-3 hours after darkness and before sunrise, and are less active during the remainder of the night. Species that show a pronounced seasonal rhythm in responsiveness to playback include eastern screech owls (Carpenter 1985, Smith et al., this proceedings), whiskered owls (Martin 1974), barred owls (Smith 1978), and spotted owls (Strix occidentalis) (Forsman et al., 1984). Several of these species are most responsive during fall and winter, corresponding with territorial establishment and defense, but become more secretive and less responsive during the spring breeding season.

The single most important weather variable negatively influencing response to song playback is wind (Siminski 1976, Forsman 1983, Smith et al. this proceedings). The decreased response rate may be due to limited range of song playback under high wind conditions, the inability of observers to hear or see responding owls, or the fact that owls may be comparatively inactive because of difficulties involved in efficient flight or foraging; perhaps they are unable to hear prey as well. Temperature extremes, especially low temperatures, decrease response rate of eastern screech owls (Beatty 1977, Casner 1974, Smith and McKay 1984, Carpenter, this proceedings).

Cloud cover and type of precipitation also may influence response rate of some owls, but as yet have not been sufficiently studied. Wolfgang Scherzinger (pers. commun.) has suggested that, for some European owls, changes in barometric pressure will stimulate increased activity, including spontaneous singing.

Johnson et al., (1979, 1981) found that response rates of western screech owls and elf owls (Micrathene whitneyi) varied with the lunar cycle, with both species being most active on clear, moonlit nights, but Smith et al. (this proceedings) was unable to document a similar relationship in eastern screech owls. Intensity and type of noise influenced screech owl response (Smith et al, this proceedings) although individuals varied considerably in tolerance to noises associated with human activity. Species



Eastern Screech Owl sunning at cavity entrance. Visual censusing necessitates that owls exhibit diurnal behavioral patterns that render them observable if not conspicuous. Photo by A. Devine

such as the screech owl may be much more tolerant of human noises than other owl species.

Several biological and behavioral factors may influence response to song playback or general detectability; sex, age, breeding status, and number of breeding pairs in an area have been especially noted. Spotted owl response is lower during years when few pairs breed (Forsman 1983). Hirons (1976) reported that tawny owls sing more often when territories are small and adjacent. Wolfgang Scherzinger (pers. commun.) noted that in some European species, the older, established owls are much less responsive than younger owls.

Siminski (1976) and Springer (1978) found that female great horned owls are less responsive than males and thus more difficult to census. Conversely female eastern screech owls, especially those with territories, responded alone or dueted with their mates in response to song playback within their territory (Smith et al. this proceedings).

The presence of larger owls may also decrease responses. Bondrup-Nielsen (1984) observed that a boreal owl stopped singing when a great horned owl vocalized nearby. Marshall (1939) observed that a flammulated owl (*Otus flammeolus*) became silent when a spotted owl called.

An important factor that decreased the response frequency in eastern screech owls was accommodation of individuals to frequent or extensive song playback (Smith et al. this proceedings). Accommodation has also been found in tawny owls (Hirons 1976) and boreal owls (Bondrup-Nielsen 1984) and may in fact, occur in many owl species.

Negative Effects of Playback

Although song playback is effective in locating and studying owls, it should not be used

indiscriminately. Responding birds may vocalize for some time after playback, and could be more easily located by predators. Small owls are sometimes captured by larger owls, and some larger owls (spotted, barred, and great gray) have been recorded in the diet of great horned owls (Forsman et al. 1984, Bent 1938; Duncan, this proceeding, others).

Responding to playback reduces time for normal activities of the owl. In montane forests of Colorado, Palmer and Rawinski (1986) used song playback to locate boreal owls during September and October in order to avoid disrupting courtship. In addition, it may be possible for frequent and persistent playback to frighten owls from their territory or alter their territorial boundaries; although not documented in any North American species, this has been noted as a problem in Europe (Wolfgang Scherzinger, person. commun.). It is also possible that louder-than-normal playback continued for long duration may act as a super-stimulus, drawing owls from much longer distances than would otherwise occur.

LITERATURE CITED

- Baumgartner, F. M. 1939. Territory and population in the great horned owl. *Auk* 56:274-282.
- Beatty, W. H. 1977. Attracting screech owls. *Redstart* 44:102-104.
- Bent, A. C. 1938. Life histories of North American birds of prey. Part 2, U.S. National Museum Bulletin 170 pp.
- Bondrup-Nielsen, S. 1984. Vocalization of the boreal owl (*Aegolius funereus richardsonii*) in North America. *Canadian Field Naturalist* 98:191-197.
- Carpenter, T. W. 1985. The effects of environmental conditions on the responses of eastern screech owls to playback of tape recorded calls. M.S. Thesis, University of Wisconsin-Milwaukee.
- Casner, T. R. 1974. Winter owl census. *Jack Pine Warbler* 52:45-46.
- Craighead, J. J., and F. C. Craighead, Jr. 1956. Hawks, owls and wildlife. The Stackpole Company., Harrisburg, PA
- Forsman, E. D. 1983. Methods and materials for locating and studying spotted owls. U.S. Forest Service General Technical Report, PNW-162.
- Forsman, E. D., E. C. Meslow and H. M. Wight. 1984. Distribution and biology of the spotted owl in Oregon. *Wildlife Monograph* 87:1-64.
- Fuller, M. R., and J. A. Mosher. 1981. Methods of detecting and counting raptors: a review. *Studies in Avian Biology*. 6:235-246.
- Hirons, G. J. M. 1976. A population study of the tawny owl (*Strix aluco*) and its main prey species in woodland. Ph.D. Thesis, University Oxford, Cambridge.
- Holmgren, T. 1979. Point transect census of tengmalm's owl--a methodological study. *Var Fagelvard* 38:237-244.
- Johnson, R. R., C. T. Haight and J. M. Simpson.

1979. Owl populations and species status in the southwestern United States. Pp. 40-59 in Proceedings of symposium on owls of the west: their ecology and conservation. P. P. Schaeffer and S. M. Ehlers, eds. Tiburon, California National Audubon Society Western Education Center.
- Johnson, B. T. Brown, L. T. Haight and J. M. Simpson. 1981. Playback recordings as a special avian censusing technique. Studies in Avian Biology 6:68-75.
- Marshall, J. T. 1939. Territorial behavior of the flammulated screech owl. Condor 41:71-78.
- Martin, D. J. 1974. Copulatory and vocal behavior of a pair of whiskered owls. Auk 91:619-624.
- McPherson, R. J., and R. D. Brown. 1981. Mobbing responses of some passerines to the calls and location of the screech owl. Raptor Research 15:23-30.
- Miller, L. 1930. The territorial concept in the horned owl. Condor 32:290-291.
- Orians, G., and F. Kuhlman. 1956. Red-tailed hawk and horned owl populations in Wisconsin. Condor 58:371-385.
- Palmer, D. A., and J. J. Rawinski. 1986. A technique for locating boreal owls in the fall in the Rocky Mountains. Colorado Field Ornithology 20:38-41.
- Ralph, C. J. and J. M. Scott. 1981. Estimating numbers of terrestrial birds. Studies in Avian Biology No. 6:1-630.
- Siminski, D. P. 1976. A study of the great horned owls (Bubo virginianus) population density with recorded calls in northwestern Ohio. M. S. Thesis, Bowling Green State University, Bowling Green, Ohio.
- Smith, C. F. 1978. Distributional ecology of barred and great horned owls in relation to human disturbance. M. S. Thesis, University of Connecticut, Storrs.
- Smith, D. G., and B. McKay. 1984. The effects of weather and effort on Christmas Bird Counts of owls in Connecticut. American Birds 38:383-387.
- Smith, D. G., and J. R. Murphy. 1973. Breeding ecology of raptors of the eastern Great Basin Desert of Utah. Brigham Young University Biology Series 18:1-76.
- Springer, M. A. 1978. Foot surveys versus owl calling surveys: a comparative study of two great horned owl censusing techniques. Inland Bird Banding News 50:83-92.

Census of Barred Owls and Spotted Owls⁴ Tom Bosakowski⁵

Both the barred owl (Strix varia) and spotted owl (Strix occidentalis) are birds of forested terrain. Their habitats are typically mature and old-growth forest that are often dominated by conifers. Given these conditions, the only practical method to estimate the abundance of these owls is the use of some playback techniques which induce the owls to reveal their presence.

Gould (1977) and Forsman et al. (1977, 1984) surveyed populations of spotted owls in California and Oregon, respectively, using vocal imitations or tape recorded broadcasts. Sutton and Sutton (1985) and Bosakowski et al., (this proceedings) also used both methods to survey barred owls in southern and northern New Jersey, respectively. Although some investigators of the barred owl have relied completely on the use of tape playback (Gutmore 1977, Smith 1978, Elody 1983, McGarigal and Fraser 1984, 1985, Kane and Valent 1986), all

⁴ Presented at the Owl Census Techniques Workshop at the Symposium, Biology and Conservation of Northern Forest Owls, Winnipeg, Manitoba, Canada, February 3-7, 1987.

⁵ Thomas Bosakowski is a zoology doctoral student at Rutgers University, Department of Biological Sciences, Newark, NJ 07662.

have used different equipment, recordings, and sound wattage.

In northern New Jersey, Bosakowski et al. (this proceedings) found a high response rate (82.4%) of barred owls to vocal imitation or song playback during the breeding season. This rate was determined by 34 rechecks of known barred owl locations from which a positive response was recorded. This is a minimal response rate since we were unable to account for factors such as mortality or permanent relocation. Conversely, response rate during the non-breeding season was significantly lower (33.3%) suggesting that barred owls may be censused with reasonable accuracy during the breeding season, but surveys during the non-breeding season (Christmas bird counts) should be viewed with caution.

Elody (1983) believed that territory size of barred owls increased during winter and that males often vacated territories for most of the winter. Bosakowski et al., (this proceedings) found that both response rate and the number of responses by pairs decreased during winter, which hints at territory expansion and temporary pair-bond dissolution. Forsman et al., (1984) also found territory expansion in winter and similarly noted that response to calling was highest between March and September.

While most barred owl censusing has been conducted at night, both Elody (1983) and Bosakowski et al. (this proceedings) have found no apparent difference in barred owl response rate between

nocturnal and diurnal censusing. These results are not entirely unexpected since Fuller (1979) noted that radio-marked barred owls exhibited considerable diurnal activity during the breeding season. Day censusing makes it possible to search remote, rugged terrain lacking roads or suitable trails. Although the spotted owl will also respond to imitation of its calls during the day (Gould 1974, Forsman et al. 1984), most censuses have been conducted at night.

During day censuses of barred owls, investigators should remain concealed while calling because this species is generally secretive and will often flush or remain silent if the observers are detected (Bosakowski et al., this proceedings). In contrast, the spotted owl is very tame and concealment is not necessary (Forsman et al. 1984).

Stearns (1947) and Smith (1978) believed that barred owl singing was audible up to 0.7-0.8 km, therefore, census stations can potentially be spaced 1.6 km to attain systematic coverage of an area. Responses less than 2 km apart may need to be checked to determine if the owls belong to the same or adjacent territories. This determination can be facilitated by (1) simultaneous or near simultaneous singing of adjacent pairs (2) by obvious natural boundaries (Smith 1978), (3) by boundaries such as developments and highways (Bosakowski et al., this proceedings), or (4) by confirming simultaneous occupancy of the adjacent territories. Since spotted owl ranges are considerably larger (Forsman et al., 1984) than barred owl ranges (Nicholls and Warner 1972, Fuller 1979, Elody 1983) caution should be exercised when analyzing the results of censuses with song playback. Both barred and spotted owls may maintain traditional territories for successive years (Bent 1938, Forsman et al. 1984, Bosakowski et al., this proceedings), even when the individuals have changed (Forsman et al., 1984, Nicholls and Fuller, this proceedings), thereby facilitating surveys conducted over several years.

LITERATURE CITED

- Bent, A. C. 1938. Life histories of North American birds of prey. Part 2, U.S. National Museum Bulletin 170 pp.
- Elody, B. I. 1983. Techniques for capturing, marking, monitoring and habitat analysis for the barred owl in the Upper Peninsula of Michigan. M.S. Thesis, Michigan Technical University.
- Forsman, E. D., E. C. Meslow and M. J. Stubb. 1977. Spotted owl abundance in young versus old-growth forests, Oregon. Wildlife Society Bulletin 5:43-47.
- Forsman, E. D., E. C. Meslow and H. M. Wight. 1984. Distribution and biology of the spotted owl in Oregon. Wildlife Monograph 87:1-64.
- Fuller, M. R. 1979. Spatiotemporal ecology of four sympatric raptor species. Ph.D. Thesis, University of Minnesota, Duluth.

- Gould, G. I. Jr. 1974. Distribution of the spotted owl in California. Western Birds 8:131-146.
- Gutmore, D. 1978. Barred owl survey in the Pequannock Watershed. New Jersey Audubon 3:184-185.
- Kane, R., and M. Valent. 1986. North Jersey barred owl survey. Records of New Jersey Birds 12:69-70.
- McGarigal, K. and J. D. Fraser. 1984. The effect of forest stand age on owl distribution in southwestern Virginia. Journal Wildlife Management 48:1393-1398.
- Nicholls, T. H., and D. W. Warner. 1972. Barred owl habitat use as determined by telemetry. Journal Wildlife Management 32:213-224.
- Smith, C. F. 1978. Distributional ecology of barred and great horned owls in relation to human disturbance. M. S. Thesis, University of Connecticut, Storrs.
- Stearns, E. I. 1947. Notes on the abundance of the barred owl. Urner Field Observer 2:5-7.
- Sutton, C. C., and P. T. Sutton. 1985. The status and distribution of the barred owl and red-shouldered hawk in southern New Jersey. Cassinia 61:20-29.

Census of Flammulated Owls⁶ Richard T. Reynolds⁷

Flammulated owls (*Otus flammeolus*) best respond to taped or vocal imitations (Marshall 1939, Winter 1971) of their primary song from the latter part of May through early July. However, after the eggs hatch (early July), paired males cease to quickly respond to song imitations (= broadcast) but non-paired males continue to respond through the summer (Reynolds and Linkhart 1987a). During May to early July, it is best to count singing males between 1 hr after sunset and about 1 hr before sunup. If a count of singing males must continue after egg hatch, the count should not begin before 2 hrs after sunset and should end 2 hrs before sunup. Nesting males forage intensively for their families and have little time for territorial defense during these periods.

During the responsive period (May to early July) males generally begin singing within several minutes of a broadcast, but a listening period of

⁶ Presented at the Owl Census Techniques Workshop at the Symposium, Biology and Conservation of Northern Forest Owls, Winnipeg, Manitoba, Canada, February 3-7, 1987.

⁷ Richard T. Reynolds is Research Wildlife Biologist, Rocky Mountain Forest and Range Experiment Station, 222 South 22nd Street, Laramie, WY 82070.

at least 10 min. should follow each broadcast. A single broadcast bout should not exceed 1 min. It is not uncommon to have more than one male flammulated owl respond to a broadcast, and responding owls may continue singing after initial response. Neighboring males may be stimulated to sing, and as a result, the song response may spread over a wide area. Therefore it is advised to listen for several minutes before broadcasting at each new broadcast station.

Responding males may 1) begin singing without approaching, 2) approach while singing, or 3) come to their territory boundary before singing. On several occasions territorial males approached beyond their boundaries; some of these continued to sing as they did so, others approached silently and were noted perched quietly within 10 m of the broadcast station.

Because flammulated owls have quiet, low pitched voices, counters should be trained and tested for hearing capabilities before initiating a formal count. On clear, quiet nights, males singing from a ridge can be heard to 1.0 km. Due to the voice characteristics of the owl, however, it is difficult to estimate the distance to singing males. Rain, snow, wind, creeks, autos, and airplanes hindered counts of singing males. We recommend counting only on completely still nights. Moon phase has no apparent effect on the response of the males.

Linkhart et al. (in review) found that territorial boundaries of males frequently occurred along ridge tops. Therefore, counting routes are most efficient (number of responding males/distance traveled) when located along ridges. Ridge-top routes not only make for easier travel and increase the broadcast and hearing range, but expose the counter to more territories.

Because territories are approximately 400 m across (Reynolds and Linkhart 1987b), counting stations should be about 600-800 m apart in uniform terrain. In broken terrain, the distance between stations should be less; however, they should be no closer than 400 m. Counters must be aware that singing males may approach beyond their territories, especially if there are no intervening territories between the broadcast station and the approaching owl.

Not all singing males are necessarily nesting. In our studies, several responding males were unpaired for reasons probably related to

their age and/or quality of their territory (Reynolds and Linkhart 1987b). We have followed most of our counts of singing males with intensive nest searches (Reynolds and Linkhart 1984).

To estimate the density of flammulated owls on one of our study tracts, we used a modified territorial mapping technique during two nesting seasons (1980-1981). The procedure involved repeated entries by 2-3 widely-spaced persons onto the tract from different directions. After one of us broadcasted the primary song, responding males were quickly located and all subsequent song-trees used in a song bout were marked and mapped. When two or more males responded to broadcast, or when males were heard singing before broadcast, the census personnel divided and mapped the song-trees of each owl simultaneously. In both years we tallied 25-30 clusters of song-trees (territories), most of which were used in both years. In 1982 and 1983 we repeated the mapping technique after "marking" males with radio-transmitters. We subsequently discovered that males had 2-4 favored peripheral areas from which they sang, in what proved to be much larger territories. Our subsequent estimate of the number of males, reduced by about two-thirds, approximated the number of active nests on the tract.

LITERATURE CITED

- Marshall, J. T. 1939. Territorial behavior of the flammulated screech owl. *Condor* 41:71-78.
- Reynolds, R. T., and B. D. Linkhart. 1984. Methods and materials for capturing and monitoring flammulated owls. *Great Basin Naturalist* 44:49-51.
- Reynolds, R. T., and B. D. Linkhart. 1987a. The nesting biology of flammulated owls in Colorado. Symposium on The Biology and Conservation of Northern Forest Owls. Winnipeg, Manitoba. 2-7 February.
- Reynolds, R. T., and B. D. Linkhart. 1987b. Fidelity to territory and mate in flammulated owls. Symposium on The Biology and Ecology of Northern Forest Owls. Winnipeg, Manitoba. 2-7 February 1987.
- Winter, J. 1971. Some critical notes on finding and seeing the flammulated owl. *Birding* 3:205-209.



17



Rocky
Mountains



Southwest



Great
Plains

U.S. Department of Agriculture
Forest Service

Rocky Mountain Forest and Range Experiment Station

The Rocky Mountain Station is one of eight regional experiment stations, plus the Forest Products Laboratory and the Washington Office Staff, that make up the Forest Service research organization.

RESEARCH FOCUS

Research programs at the Rocky Mountain Station are coordinated with area universities and with other institutions. Many studies are conducted on a cooperative basis to accelerate solutions to problems involving range, water, wildlife and fish habitat, human and community development, timber, recreation, protection, and multiresource evaluation.

RESEARCH LOCATIONS

Research Work Units of the Rocky Mountain Station are operated in cooperation with universities in the following cities:

Albuquerque, New Mexico
Flagstaff, Arizona
Fort Collins, Colorado *
Laramie, Wyoming
Lincoln, Nebraska
Rapid City, South Dakota
Tempe, Arizona

*Station Headquarters: 240 W. Prospect St., Fort Collins, CO 80526